

SPECIFICATIONS FOR APPROVAL



Customer Part No.: _____ HELE. Part No: SSI012000I3CHE-T

Application For: _____ Products: OSCILLATOR

Accepted Model: _____ Type & Freq.: HSO531S / 12.000MHZ

Sample Order No: EOS-D50229-2 Date: 2013/05/23

Approved By :

加高電子股份有限公司

HARMONY ELECTRONICS CORP.

HARMONY ELECTRONICS (THAILAND) CO., LTD.

HARMONY ELECTRONICS (SHENZHEN) CORP., LTD.

HARMONY ELECTRONICS (SUZHOU) CO.,LTD

TAIPEI OFFICE:

公司:(114)
台北市內湖區堤頂大道 2 段 409
號 2 樓
2F., NO.409, SEC.2, TIDING
BLVD., NEIHU DISTRICT,
TAIPEI CITY 114, TAIWAN
TEL:886-2-26588883
FAX:886-2-26588683

TAIWAN FACTORY:

工廠:(831)
高雄市大寮區大發工業區華東路
39 號
No.39, HWA DONG RD.,
DALLIAO DIST.,DAFA
INDUSTRIAL PARK.,
KAOHSIUNG CITY 831,
TAIWAN
TEL: (07)787-1555-6
FAX: (07)787-1557

THAILAND FACTORY:

66MOO 5,
KAONGU-BEOKPRAI RD.,
T.BEOKPRAI, A. BANPONG,
RAJCHABUREE PROVINCE
70110, THAILAND
TEL: (032)221994-6,
200740-1
FAX: (032)200742

SHENZHEN FACTORY:

深圳市福永鎮塘尾村塘橋路聚源
工業區
QIAO TANG RD., TANGWEI
VILLAGE FU YONG TOWN
SHENZHEN CITY CHINA
TEL: 0755-27309272 /
27309262
FAX: 0755-27309755

SUZHOU FACTORY:

蘇州市相城區黃埭鎮安民路 5 號
NO.5 ANMING ROAD,
HUANGDAI TOWN,
XIANGCHENG DISTRCT,
SUZHOU CITY, JIANGSU
PROVINCE
TEL:86-512-67592373
FAX:86-512-67592363

Title				Country of origin		
HSO531S SPECIFICATION				TAIWAN FACTORY		
Date	Confirm	Check	Prepare	Spec. No.	Rev.	Page
2013/05/23	F. S. TSAI	C. L. WANG	U. F. CHEN	SSI012000I3CHE-T	0	1

HARMONY ELECTRONICS CORP.

HSO531S SPECIFICATION

INDEX

ITEM	PAGE
1. Type	3
2. Output Frequency	3
3. Absolute Maximum Ratings	3
4. Electric Specifications	3-4
5. Dimensions	5
6. Inside Structure	6
7. Mechanical Performance	6
8. Environment Performance	7
9. Supplement	8-9
10. Taping and Packing	10-12
11. Flow Chart	13
12. Environmental Workload Chemical Substance Components List .	14

Title				Country of origin		
HSO531S SPECIFICATION				TAIWAN FACTORY		
Date	Confirm	Check	Prepare	Spec. No.	Rev.	Page
2013/05/23	F. S. TSAI	C. L. WANG	U. F. CHEN	SSI012000I3CHE-T	0	2

1. Type Name :
HSO531S

2. Output Frequency :
12.000000 MHz

3. Absolute Maximum Ratings :

Item	Symbol	Value	Unit
Vdd terminal voltage	Vdd	-0.5 ~ 7.0	V
Input terminal voltage	Vcont	-0.5 ~ Vdd+0.5	V
Output terminal voltage	Vout	-0.5 ~ Vdd+0.5	V
Output terminal current	Iout	15	mA
Storage temp. range	Tstr	-55~125	deg.C

4. Electric Specifications :

Item	Symbol	Value			Unit	Condition		
		Min	Typ	Max		Etc	Vdd	Temp
Frequency Stability	$\Delta f/F$	-50	-	+50	ppm		3.3+/- 0.3V	-40~85 °C
Operating temp. range	Topr	-40	25	+85	°C			
Supply voltage	Vdd	3.0	3.3	3.6	V			
Current consumption 1 (#1 pin: open or "H")	Idd1	-	-	25	mA	Fig1,2	3.3V	25+/- 3°C
Current consumption 2 (#1 pin: "L" level)	Idd2	-	-	0.05	mA			
Symmetry	Duty	40	50	60	%			
Low level output voltage	Vol	-	-	0.1xVdd	V			
High level output voltage	Voh	0.9xVdd	-	-	V			
Rise & Fall time	Tr & Tf	-	-	10	ns			
Pin #1 options	YES							
Output load	C-MOS CL=30pF (Idd1, Idd2 test at No Load)							
Low level input current	Iil	-	-	-100	µA	Fig3	3.3V	25+/- 3°C
High Level input current	Iih	-	-	100	µA			
Low level input voltage	Vil	-	-	0.3xVdd	V			
High level input voltage	Vih	0.7xVdd	-	-	V			
Output disable time	Tplz	-	-	100	ns			
Output enable time	Tpzi	-	-	5	ms			
Aging	-	-5	-	5	ppm/year			

F :Output Frequency

Δf =Oscillation Frequency - F

Frequency Stability is inclusive of 25°C

Tolerance, operating temperature range, input voltage change,
Load chang, first of aging , shock and vibration.

Moisture Sensitivity Level : Level 1

Title HSO531S SPECIFICATION				Country of origin TAIWAN FACTORY		
Date 2013/05/23	Confirm F. S. TSAI	Check C. L. WANG	Prepare U. F. CHEN	Spec. No. SSI012000I3CHE-T	Rev. 0	Page 3

HARMONY ELECTRONICS CORP.

Fig. 1) Measurement Circuit :

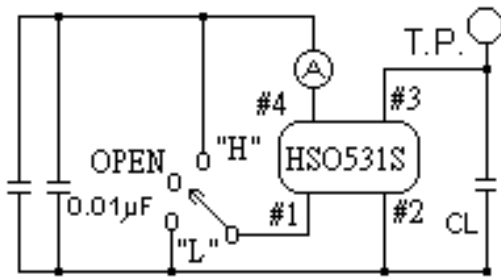

CL = Include jig & probe capacitance
(Refer to 4)

Switch	Out term.
H	Oscillation out
Open	Oscillation out
L	High Z

Fig. 2) Output Wave Form :

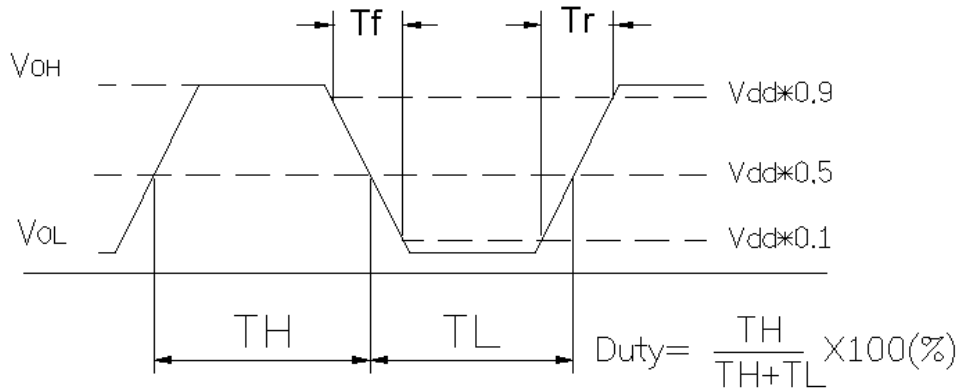
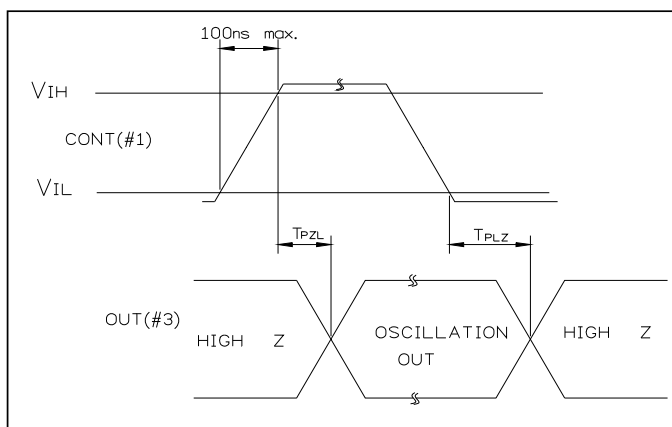
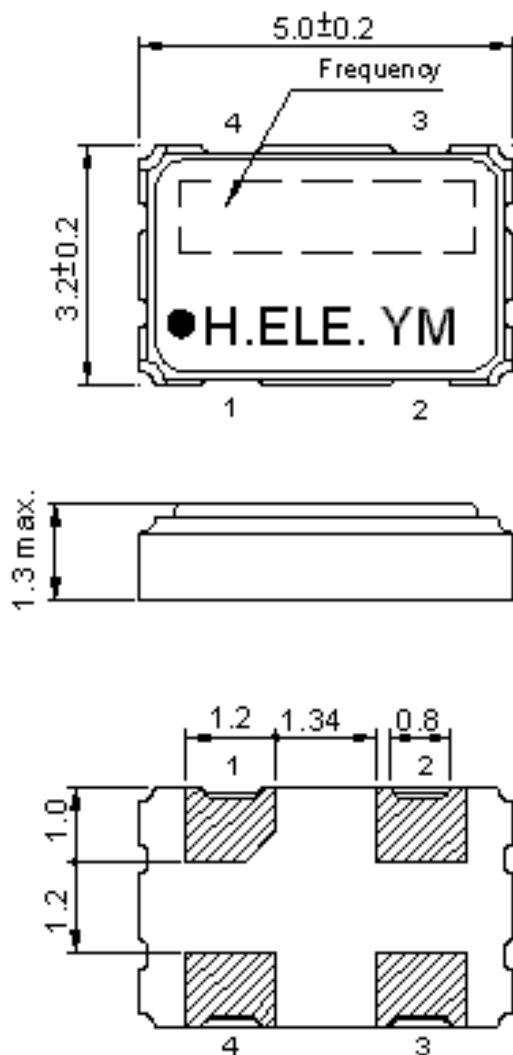

Fig. 3) Input Output Condition :



Title HSO531S SPECIFICATION				Country of origin TAIWAN FACTORY		
Date 2013/05/23	Confirm F. S. TSAI	Check C. L. WANG	Prepare U. F. CHEN	Spec. No. SSI012000I3CHE-T	Rev. 0	Page 4

5. Dimensions :



Pin Connections	
1	OE(Output Enable)
2	GND
3	Output
4	Vdd

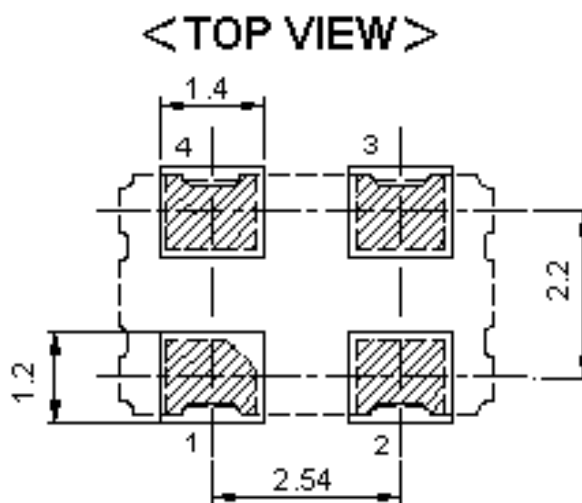

UNIT:mm
TOLERANCE:±0.2

Lot No. :

Year : Last digit of the year

Year	2000	2001	2002	2003	2004	2005	2006	2007	2008	2009
	2010	2011	2012	2013	2014	2015	2016	2017	2018	2019
Code	0	1	2	3	4	5	6	7	8	9

Month : Alphabet assign below

Month	1	2	3	4	5	6	7	8	9	10	11	12
Code	A	B	C	D	E	F	G	H	J	K	L	M

Marking : Laser marking

Title HSO531S SPECIFICATION				Country of origin TAIWAN FACTORY		
Date 2013/05/23	Confirm F. S. TSAI	Check C. L. WANG	Prepare U. F. CHEN	Spec. No. SSI012000I3CHE-T	Rev. 0	Page 5

HARMONY ELECTRONICS CORP.

6. Inside Structure :

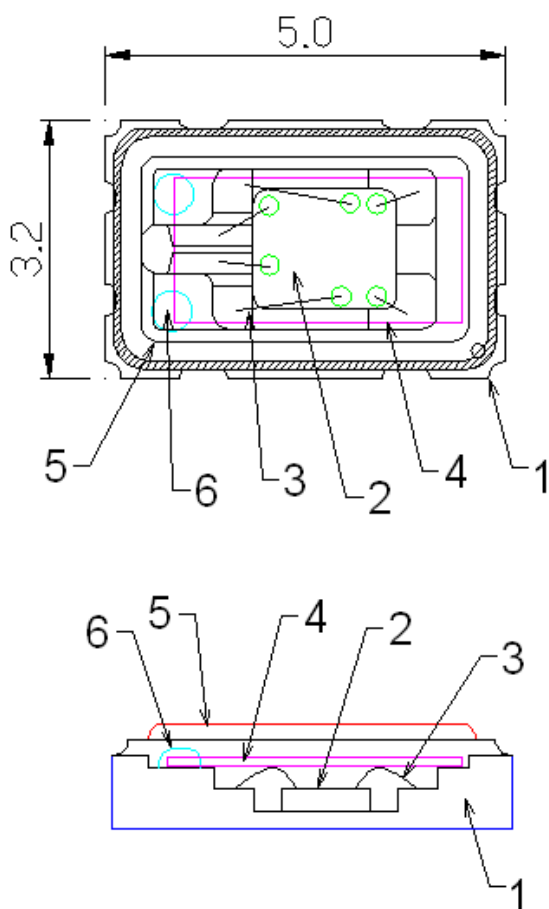

Reference drawing

(1) Base:	Alumina Ceramic (Al_2O_3) Metallized Pad: W Ni Plating Au Plating
(2) IC:	IC(Si. Al.)
(3) Au Bonding Wire:	Au
(4) Crystal Blank	Rectangular At-Cut Quartz Crystal Blank
(5) LID:	Fe+Ni+Co
(6) Adhesive	Silver Conductive Silicon Resin

The use prohibition chemistry substance of Table 1 of DHE-0204-1 (HE-QA-24) is not included in this item.

7. Mechanical Performance :

Item		Test Methods	Specifications Code
1	Natural Drop	Drop 3 times from the height of 50cm onto min. 30mm thickness hard wooden board.	A
2	Vibration	Frequency 10-55Hz, Sine Wave full amplitude of 0.8mm to X, Y and Z 3 axes, Duration of 2 hours to each axis.	A
3	Sealing Tightness	(1) Leak Rate 1.0×10^{-8} Pa-m ³ /sec. Max. Measured by Helium leak detector. – Fine Leakage. (2) Dipping in the FC-40 at +125 +/-5deg.C for 5 minutes, no gas bubble observed from the inside of the can.	---
4	Solderability	After applying ROSIN Flux, dipping in solder bath at 245deg.C +/-5deg.C for 3 +/-0.5 sec.	B

Title				Country of origin		
HSO531S SPECIFICATION				TAIWAN FACTORY		
Date	Confirm	Check	Prepare	Spec. No.	Rev.	Page
2013/05/23	F. S. TSAI	C. L. WANG	U. F. CHEN	SSI012000I3CHE-T	0	6

8. Environment Performance :

Item		Test Methods	Specifications Code
1	Humidity	Temperature 60°C +/-2°C, RH 90~95%, Duration of 240 hours. Back to room temperature first, then in 1~2 hours, the component shall be checked.	A
2	Storage in Low Temperature	-40deg.C +/-2deg.C, Duration of 240 hours. Back to the room temperature first, then in 1~2 hours, the component shall be checked.	A
3	Storage in High Temperature	+85deg.C +/-2deg.C, Duration of 240 hours. Back to the room temperature first, then in 1~2 hours, the component shall be checked.	A
4	Temperature cycles	-30deg.C +/-2deg.C (30min) ↔ +80deg.C +/-2deg.C (30min) 25 cycles. Temp. increasing or reducing time need to be within 3 minutes. Back to the room temperature first, then in 1~2 hours, the component shall be checked.	A
5	High Temperature Operation	+85deg.C +/-2deg.C, +3.3V Vdd Duration of 240 hours. Back to the room temperature first, then in 1~2 hours, the component shall be checked.	A

Specifications code	Specifications
A	Frequency variation shall be within +/-5ppm and equivalent resistance shall be within the specification after the test
B	More than 90% of lead shall be covered by new solder.

Title				Country of origin		
HSO531S SPECIFICATION				TAIWAN FACTORY		
Date	Confirm	Check	Prepare	Spec. No.	Rev.	Page
2013/05/23	F. S. TSAI	C. L. WANG	U. F. CHEN	SSI012000I3CHE-T	0	7

9. Supplement :

9.1. Please stay with our proposed reflow condition and do then soldering 2 times max.

Available for Lead Free Soldering

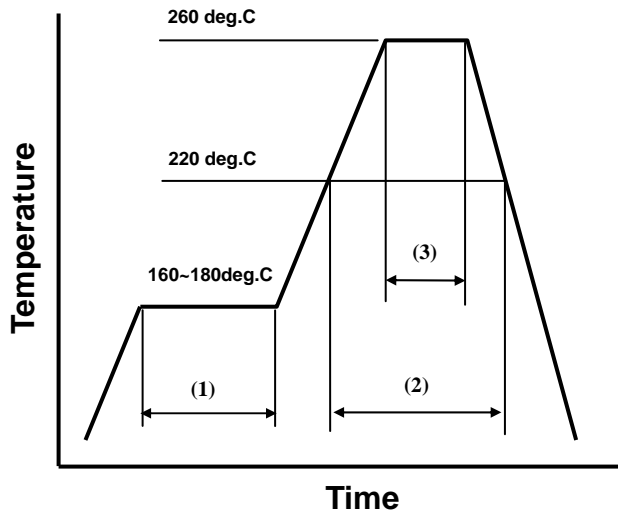

(1)	Preheat	160~180 deg.C	120sec.
(2)	Primary heat	220 deg.C	60sec.
(3)	Peak	260 deg.C	10sec. Max.

9.2. Land Pattern Layout : (Example)

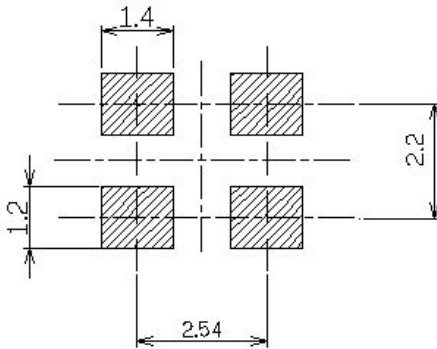

9.3. Solder Iron : (Example)

Bit temp.: 350deg.C Max. , Time: 3sec Max. , Each terminal solder a 1 time Max.

Title HS0531S SPECIFICATION				Country of origin TAIWAN FACTORY		
Date 2013/05/23	Confirm F. S. TSAI	Check C. L. WANG	Prepare U. F. CHEN	Spec. No. SSI012000I3CHE-T	Rev. 0	Page 8

9.4.Mounting :

This component is designed for automatic insertion.
However, you are requested to do the trial with your insertion machine in order to be sure of proper operation and no damage of component.
Please pay attention to board warp which may damage the component and cause Soldering Process.

9.5.Cleaning :

Cleaning liquid which corrodes Nickel shall not be used.
It may cause the problem on the surface, color, marking etc.
Ultra-sonic cleaning is possible, however, you are requested to check on your board.
Because we only checked as single unit.

9.6.Handling :

HSO531S series is designed to withstand Drop and Vibration, however, the crystal blank might be broken. So, if excess force is given, please check the characteristics before use.
HSO531S series has C-MOS circuit inside. Please pay attention to static-electricity as same handling as other C-MOS. devices.

9.7.By-pass Capacitor :

It has no by-pass capacitor integrated. We recommend you to use capacitor (like ceramic chip capacitor) 0.01 μ F in-between Vdd and GND.

9.8.Storage :

Please keep away from high temperature and high humidity, which may cause put solderability. No direct Sunlight, No dew as well.

Title				Country of origin		
HSO531S SPECIFICATION				TAIWAN FACTORY		
Date	Confirm	Check	Prepare	Spec. No.	Rev.	Page
2013/05/23	F. S. TSAI	C. L. WANG	U. F. CHEN	SSI012000I3CHE-T	0	9

10. Taping and Packing :

10.1. Emboss Tape Specifications :

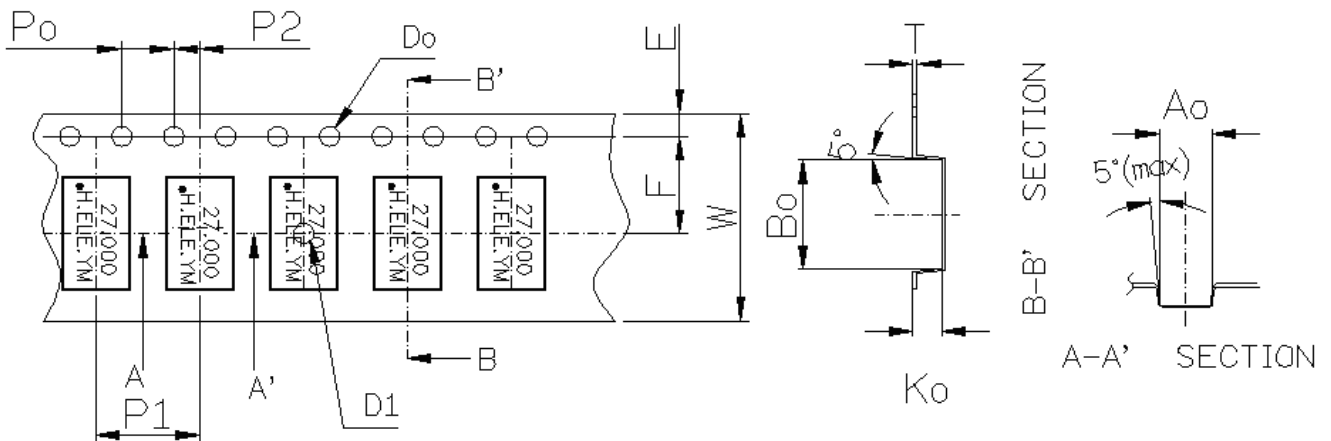

Symbol	A ₀	B ₀	K ₀	P ₀	P ₁	P ₂	T
Spec	3.60±0.1	5.40±0.1	1.40±0.1	4.0±0.1	8.0±0.1	2.0±0.05	0.30±0.05
Symbol	E	F	D ₀	D ₁	W	10P ₀	
Spec	1.75±0.1	5.50±0.05	1.55±0.05	1.50(min)	12.0±0.2	40.0±0.1	

10.2. Reel Specifications :

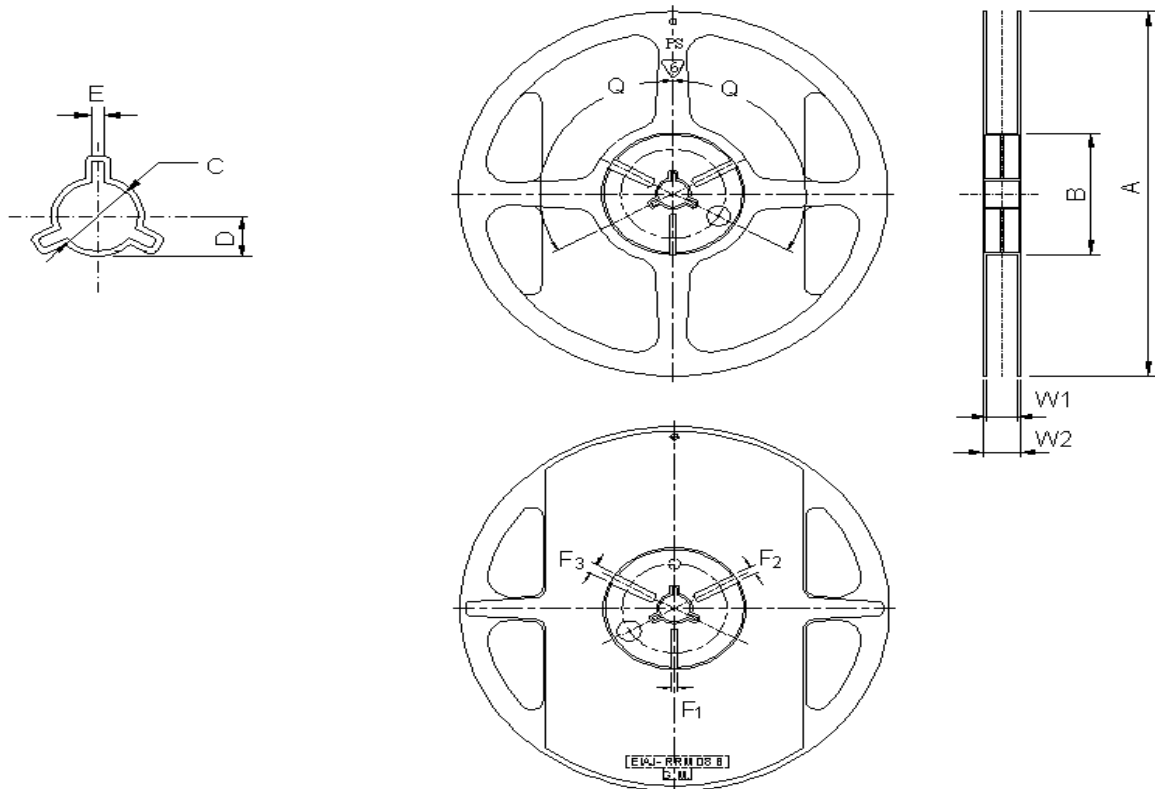

Title HS0531S SPECIFICATION				Country of origin TAIWAN FACTORY		
Date 2013/05/23	Confirm F. S. TSAI	Check C. L. WANG	Prepare U. F. CHEN	Spec. No. SSI012000I3CHE-T	Rev. 0	Page 10

HARMONY ELECTRONICS CORP.

(Table-2)

(UNIT: mm)

ITEM		MARK	DIMENSIONS · ANGLE	
FLANCE	Diameter	A	ϕ 180+0/-3	
	Inner Width	W1	12.8+/-0.3	
	Outer Width	W2	15.5+/-1.0	
HUB	Out Line diameter	B	ϕ 60.5+/-0.5	
	Center Core slit	Width	F1	3.0+0.5/-0
			F2	4.0+0.5/-0
			F3	5.0+0.5/-0
		Position	q	120deg
	Spindle diameter		C	ϕ 13.2+/-0.5
Key Ditch	Width	E	3.0+/-0.2	

10.3.Storage :

Temperature+40deg.C Max.

Humidity 80% Max.

10.4.Quantity on Reel :

1,000 PCS/REEL

10.5.Label :

Label is following information :

	
TYPE:	
SPEC.No.:	
Parts No.:	
LotNo.:	
FREQ.:	MHz
Q'TY:	PCS
HARMONY ELECTRONICS CORP. H.ELE. HSF	

Title HSO531S SPECIFICATION				Country of origin TAIWAN FACTORY		
Date 2013/05/23	Confirm F. S. TSAI	Check C. L. WANG	Prepare U. F. CHEN	Spec. No. SSI012000I3CHE-T	Rev. 0	Page 11

HARMONY ELECTRONICS CORP.

10.6. PACKAGE :

1.Reel : \varnothing 180

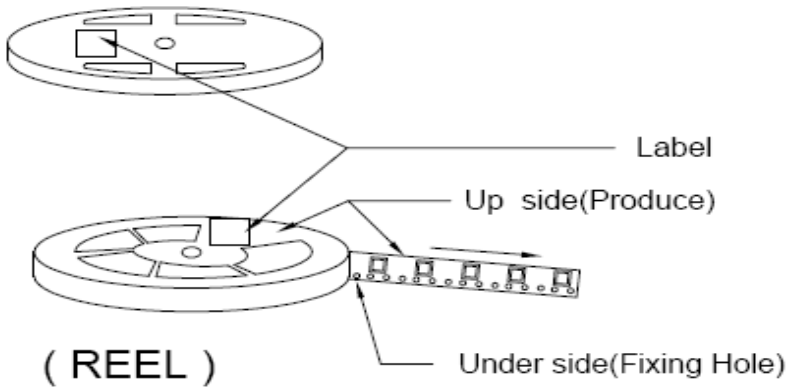

TYPE:	
SPEC. No.:	
Parts No.:	
Lot No.:	
FREQ.:	MHz
Q'TY:	PCS
HARMONY ELECTRONICS CORP. H.H.H. HSF	

2. Carton

One reel quantity:[1000pcs] &[3000pcs]

- ①Top and bottom with 2.3cm thickness foam-rubber cushion for protection.
- ②Carton's Q'TY:1~15 pcs.
- ③Carton Type=A,B,C use 4 trigon pillar to fasten the Reel.
- ④Need to add 3 pages dry agent in each outer box.

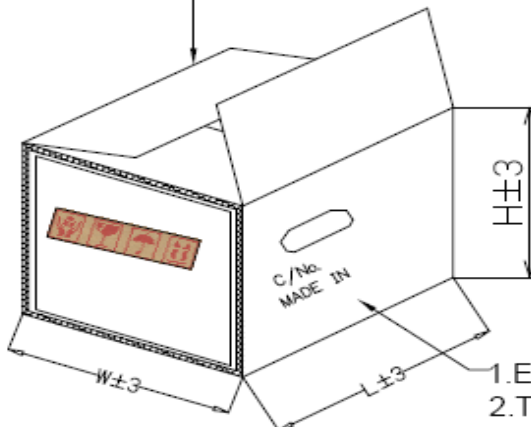
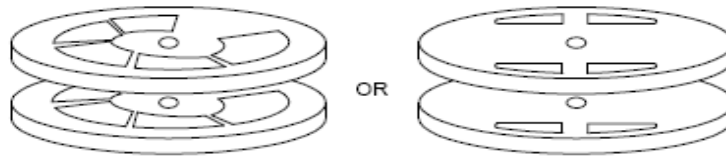
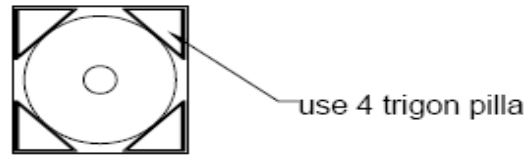

Carton Type	A	B	C	D
Produce Type	840/751	630/531/ 421	321/21	OTHER
Reel	15	15	15	1~7
L±3	200	200	200	195
W±3	200	200	200	195
H±3	230	230	230	150

(Carton)

- 1. Every Carton with 3 desiccant.
- 2. Top and bottom with 2.3cm thickness foam-rubber cushion for protection

Title HS0531S SPECIFICATION				Country of origin TAIWAN FACTORY		
Date 2013/05/23	Confirm F. S. TSAI	Check C. L. WANG	Prepare U. F. CHEN	Spec. No. SSI012000I3CHE-T	Rev. 0	Page 12

11. Flow Chart :

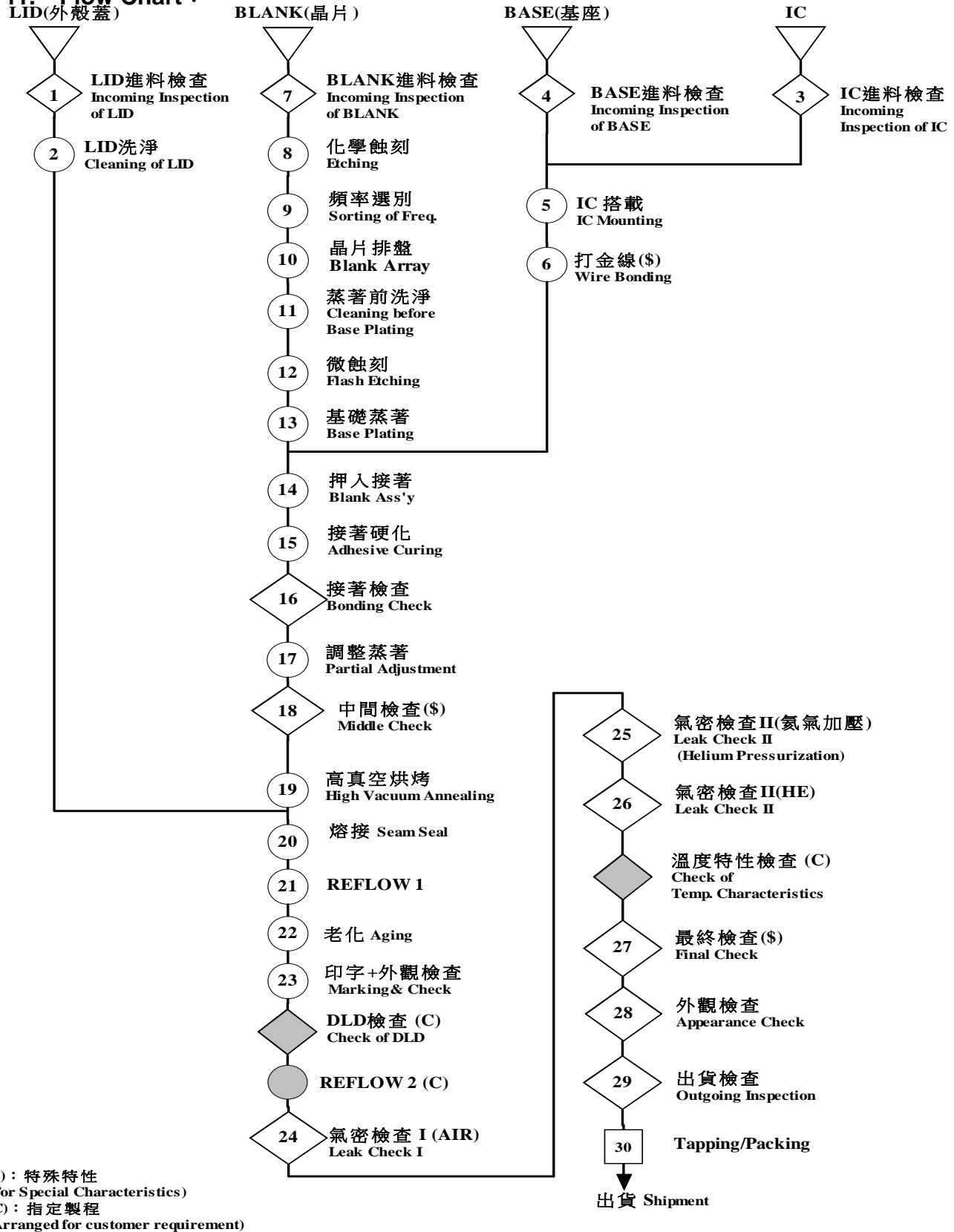

Title HS0531S SPECIFICATION				Country of origin TAIWAN FACTORY		
Date 2013/05/23	Confirm F. S. TSAI	Check C. L. WANG	Prepare U. F. CHEN	Spec. No. SSI012000I3CHE-T	Rev. 0	Page 13

12. Environmental Workload Chemical Substance Components List

Environmental Workload Chemical Substance Components List		
TYPE PERCENTAGE Chemical Substance Components	HSO531S	
	56(mg)	ppm
WOLFRAM AND ITS COMPOUND(W)	6.739	4312.960
COBALT AND ITS COMPOUND(Co)	3.082	1972.480
CHROMIUM AND ITS COMPOUND(Cr)	0.000	0.000
SILVER(Ag)	0.986	631.040
COPPER(Cu)	0.179	114.560
NICKEL AND ITS COMPOUND(Ni)	6.849	4383.360
MANGANESE AND ITS COMPOUND(Mn)	0.025	16.000
MOLYBDENUM AND ITS COMPOUND(Mo)	0.111	71.040
SILICON AND ITS COMPOUND(Si)	1.518	971.520
ALUMINIUM AND ITS COMPOUND(Al)	28.820	18444.800
GOLD(Au)	0.691	442.240

Title HSO531S SPECIFICATION				Country of origin TAIWAN FACTORY		
Date 2013/05/23	Confirm F. S. TSAI	Check C. L. WANG	Prepare U. F. CHEN	Spec. No. SSI012000I3CHE-T	Rev. 0	Page 14

HARMONY ELECTRONICS CORP.

REV. No.	DATE	REASON	CONTENTS
0	2013/05/23	New	

Title				Country of origin		
HS0531S SPECIFICATION				TAIWAN FACTORY		
Date	Confirm	Check	Prepare	Spec. No.	Rev.	Page
2013/05/23	F. S. TSAI	C. L. WANG	U. F. CHEN	SSI012000I3CHE-T	0	15

HARMONY ELECTRONICS CORP.