

PLASTIC-ENCAPSULATE TRANSISTORS

PXT8050(NPN)

FEATURES

- Complimentray to PXT8550



APPLICATIONS

- This device is designed as a general purpose amplifier and switching.

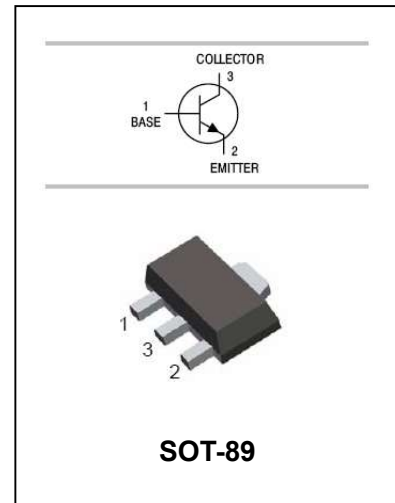

ORDERING INFORMATION

Type No.	Marking	Package Code
PXT8050□	8050	SOT-89

□: none is for Lead Free package;

“G” is for Halogen Free package.

MAXIMUM RATING @ Ta=25°C unless otherwise specified

Symbol	Parameter	Value	Unit
V _{CBO}	Collector-Base Voltage	40	V
V _{CEO}	Collector-Emitter Voltage	25	V
V _{EBO}	Emitter-Base Voltage	6	V
I _C	Collector Current -Continuous	1.5	A
I _B	Base Current-Continuous	500	mA
P _C	Collector Power dissipation	0.5	W
T _j	Junction Temperature	150	°C
T _{stg}	Storage Temperature	-55 to +150	°C

PLASTIC-ENCAPSULATE TRANSISTORS

PXT8050(NPN)

ELECTRICAL CHARACTERISTICS @ Ta=25°C unless otherwise specified

Parameter	Symbol	Test conditions	MIN	MAX	UNIT
Collector-base breakdown voltage	$V_{(BR)CBO}$	$I_C=100\mu A, I_E=0$	40		V
Collector-emitter breakdown voltage	$V_{(BR)CEO}$	$I_C=0.1mA, I_B=0$	25		V
Emitter-base breakdown voltage	$V_{(BR)EBO}$	$I_E=100\mu A, I_C=0$	5		V
Collector cut-off current	I_{CBO}	$V_{CB}=40V, I_E=0$		0.1	μA
Emitter cut-off current	I_{CEO}	$V_{CE}=20V, I_E=0$		0.1	μA
Emitter cut-off current	I_{EBO}	$V_{EB}=5V, I_C=0$		0.1	μA
DC current gain	h_{FE}	$V_{CE}=1V, I_C=100mA$ $V_{CE}=1V, I_C=800mA$	85 40	400	
Collector-emitter saturation voltage	$V_{CE(sat)}$	$I_C=800mA, I_B=80mA$		0.5	V
Base-emitter saturation voltage	$V_{BE(sat)}$	$I_C=800mA, I_B=80mA$		1.2	V
Base-emitter voltage	V_{BE}	$V_{CE}=1V, I_C=10mA$		1	V
Base-emitter positive forward voltage	V_{BEF}	$I_B=1A$		1.55	V
Transition frequency	f_T	$V_{CE}=10V, I_C=50mA,$ $f=30MHz$	100		MHz
Output Capacitance	C_{ob}	$V_{CB}=10V, f=1MHz, I_E=0$		15	pF

CLASSIFICATION OF $h_{FE(1)}$

Rank	B	C	D	D3
Range	85-160	120-200	160-300	300-400

PLASTIC-ENCAPSULATE TRANSISTORS

PXT8050(NPN)

TYPICAL CHARACTERISTICS @ $T_a=25^\circ\text{C}$ unless otherwise specified

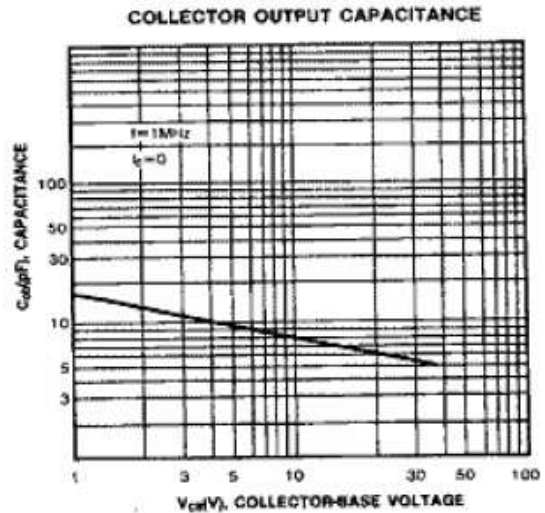
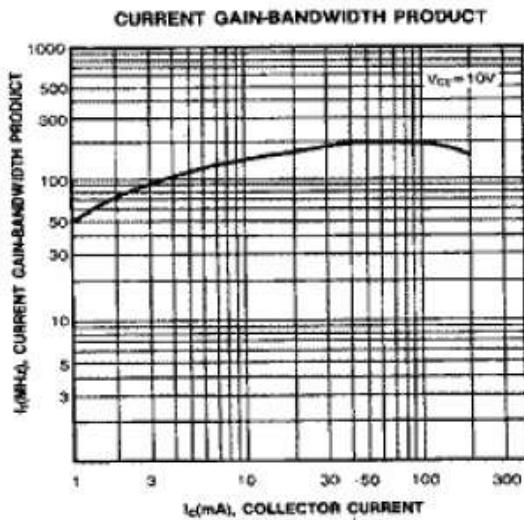
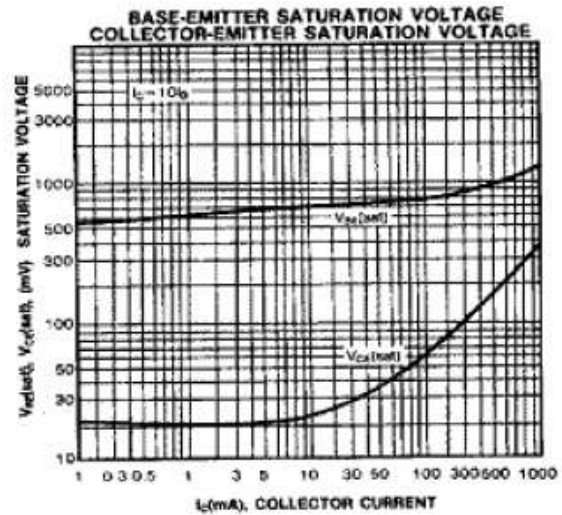
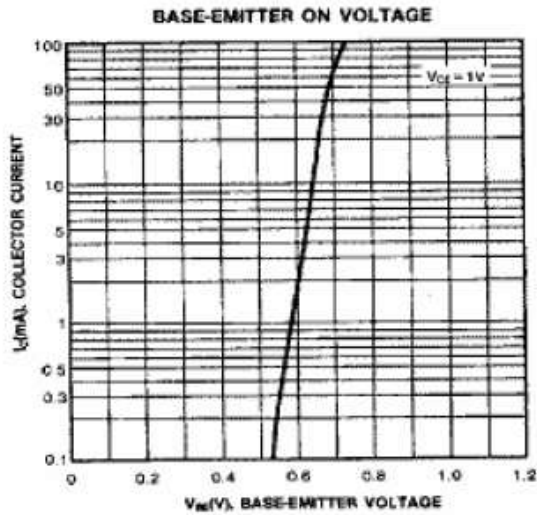
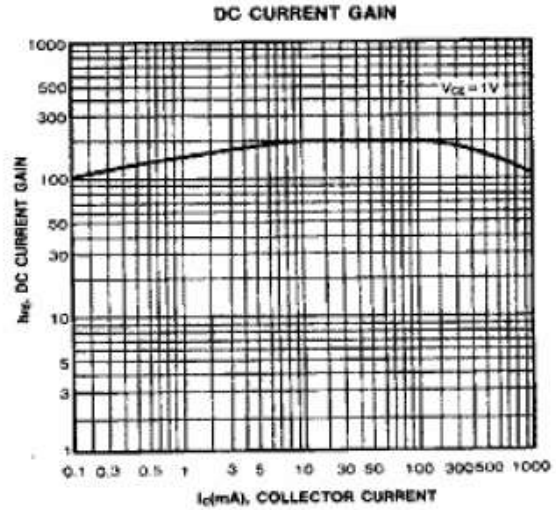
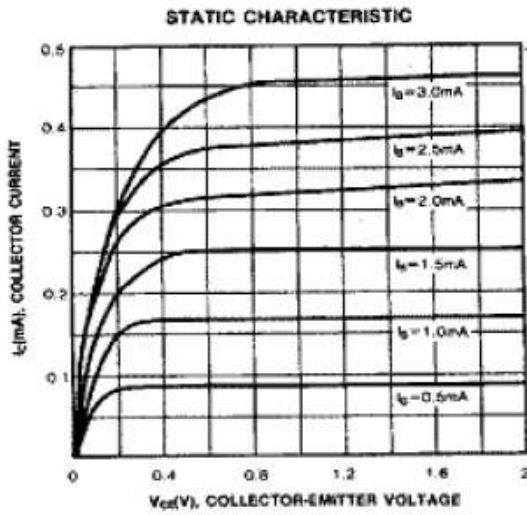

PLASTIC-ENCAPSULATE TRANSISTORS

PXT8050(NPN)

PACKAGE OUTLINE

Plastic surface mounted package

SOT-89

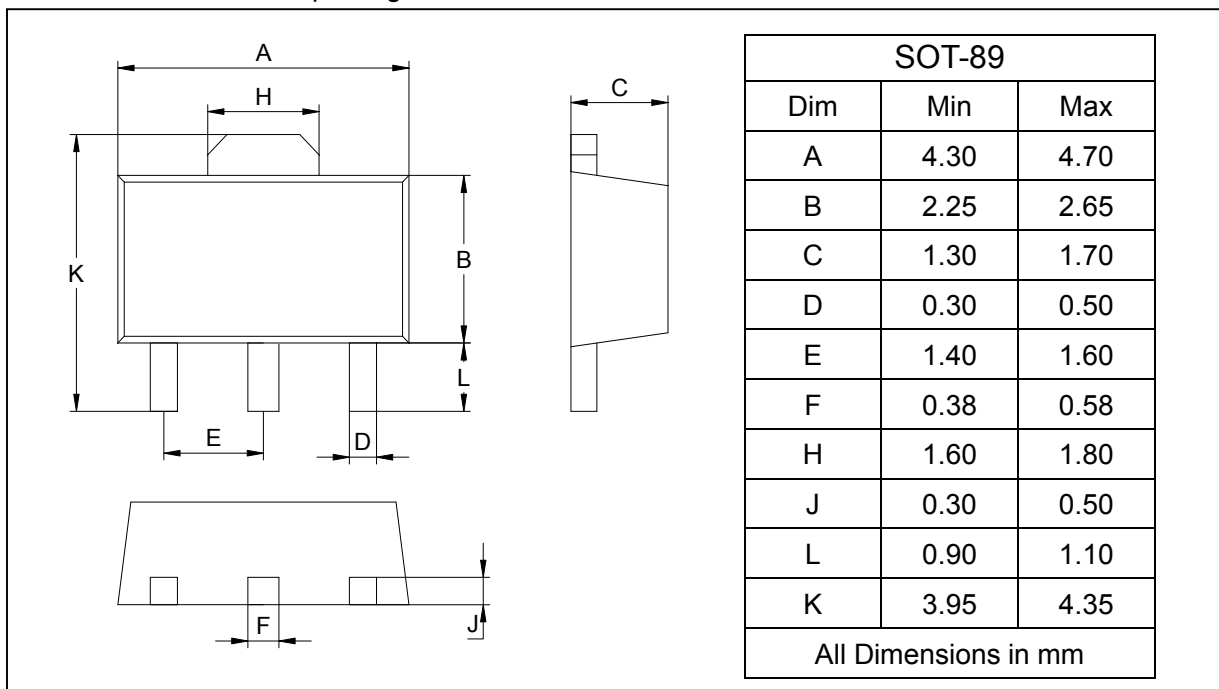

SOLDERING FOOTPRINT

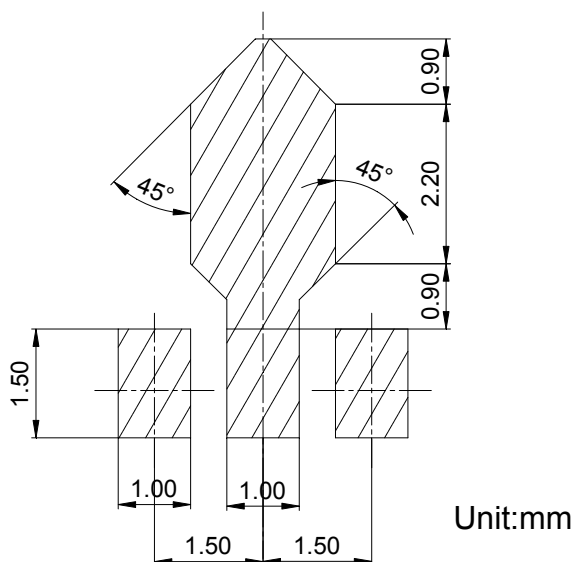

PACKAGE INFORMATION

Device	Package	Shipping
PXT8050	SOT-89	1000/Tape&Reel