



**晶体管**  
**TRANSISTOR**  
**S8550DA**

**主要参数 MAIN CHARACTERISTICS**

I <sub>c</sub>	-1.5A
V <sub>CEO</sub>	-45V
P <sub>c</sub>	1W

**产品特性 FEATURES**

硅外延	Epitaxial silicon
高开关速度	High switching speed
与 S8050DA 互补	Complementary to S8050DA
RoHS 产品	RoHS product

**用途 APPLICATIONS**

高频开关电源	High frequency switch power supply
一般功率放大电路	Commonly power amplifier circuit
高频功率变换	High frequency power transform

**封装形式 Package**



1. Emitter 2. Base 3. Collector      TO-92

**绝对最大额定值 ABSOLUTE RATINGS (T<sub>c</sub>=25°C)**

项目 Parameter	符号 Symbol	数值 Value	单位 Unit
集电极—基极直流电压 Collector- Base Voltage ( I <sub>E</sub> =0 )	V <sub>CB0</sub>	-70	V
集电极—发射极直流电压 Collector- Emitter Voltage ( I <sub>B</sub> =0 )	V <sub>CEO</sub>	-45	V
发射极—基极直流电压 Emitter-Base Voltage ( I <sub>C</sub> =0 )	V <sub>EB0</sub>	-6	V
最大集电极直流电流 Collector Current ( DC )	I <sub>c</sub>	-1.5	A
最大集电极耗散功率 Total Dissipation ( TO-92 )	P <sub>c</sub>	1	W
最高结温 Junction Temperature	T <sub>j</sub>	150	°C
贮存温度 Storage Temperature	T <sub>stg</sub>	-55~+150	°C

## 电特性 ELECTRICAL CHARACTERISTICS

项目 Parameter	测试条件 Tests conditions	最小值 (min)	典型值 (typ)	最大值 (max)	单位 Unit
$V(BR)_{CBO}$	$I_C = -0.1\text{mA}, I_E = 0$	-70	-	-	V
$V(BR)_{CEO}$	$I_C = -2.0\text{mA}, I_B = 0$	-45	-	-	V
$V(BR)_{EBO}$	$I_E = -0.1\text{mA}, I_C = 0$	-6	-	-	V
$I_{CBO}$	$V_{CB} = -35\text{V}, I_E = 0$	-	-	-0.1	$\mu\text{A}$
$I_{EBO}$	$V_{EB} = -6\text{V}, I_C = 0$	-	-	-0.1	$\mu\text{A}$
$H_{fe}(1)$	$V_{CE} = -1\text{V}, I_C = -100\text{mA}$	160	-	320	-
$H_{fe}(2)$	$V_{CE} = -1\text{V}, I_C = -800\text{mA}$	40	-	-	-
$H_{fe}(3)$	$V_{CE} = -1\text{V}, I_C = -5.0\text{mA}$	45	-	-	-
$V_{CE(sat)}$	$I_C = -800\text{mA}, I_B = -80\text{mA}$	-	-	-0.5	V
$V_{BE(sat)}$	$I_C = -800\text{mA}, I_B = -80\text{mA}$	-	-	-1.2	V
$f_T$	$V_{CE} = -10\text{V}, I_C = -50\text{mA}$	100	-	-	MHz

### 放大倍数 hFE Classifications

hFE Classifications	D
hFE Range	160-300

典型特性曲线 **Electrical Characteristics**

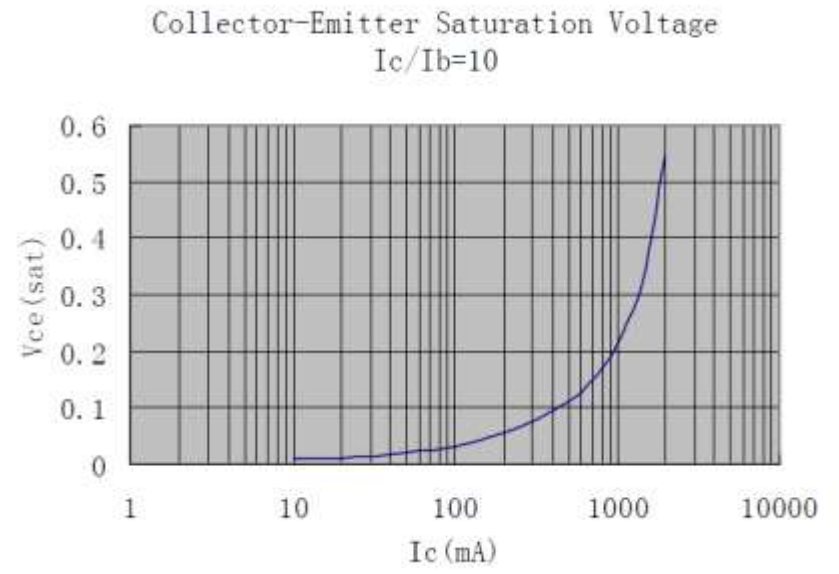
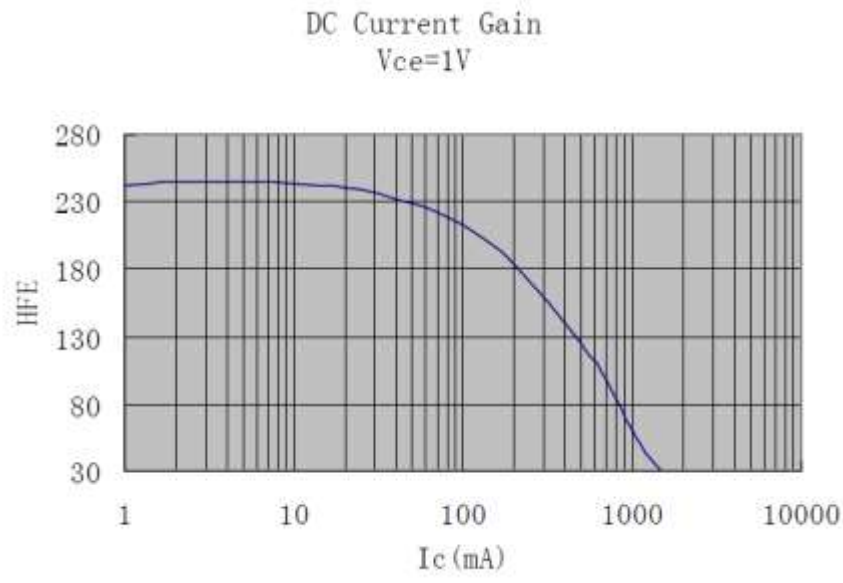

印记: Marking:

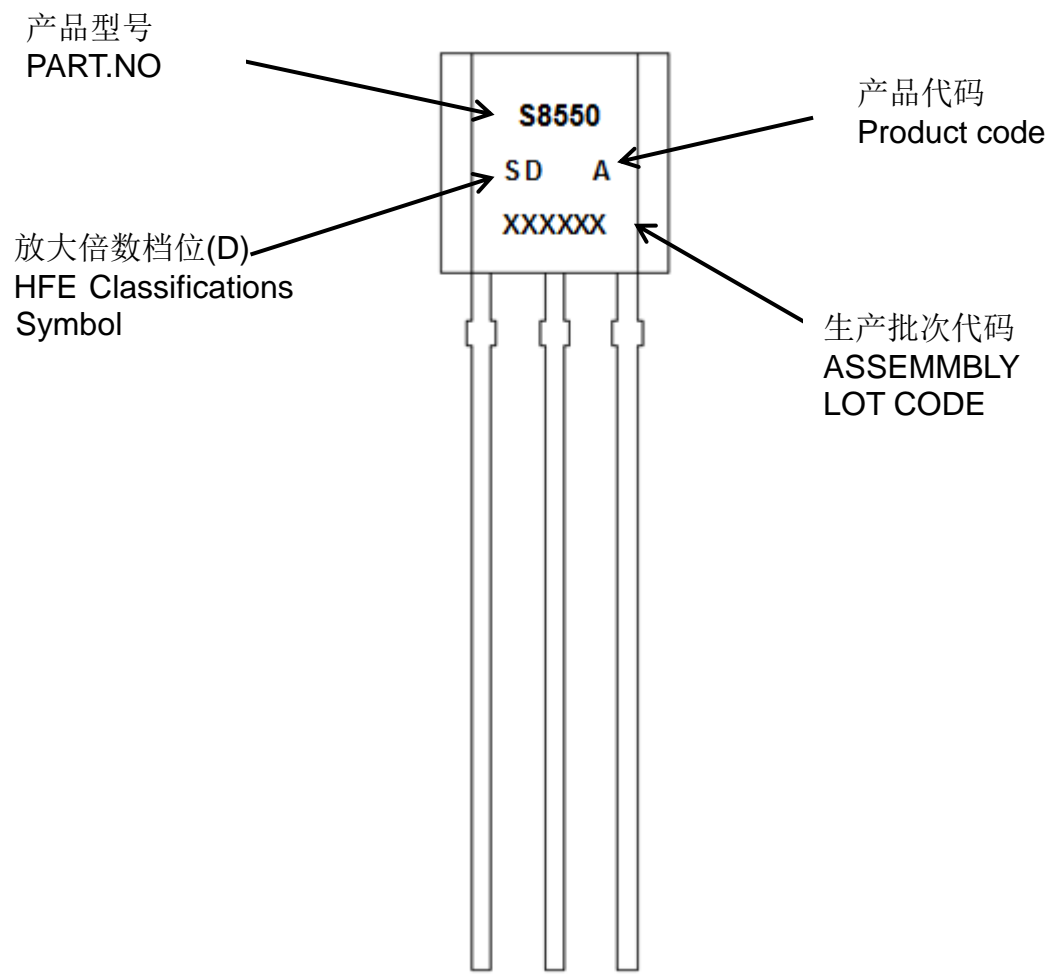

外形尺寸: Package Dimension

T0-92

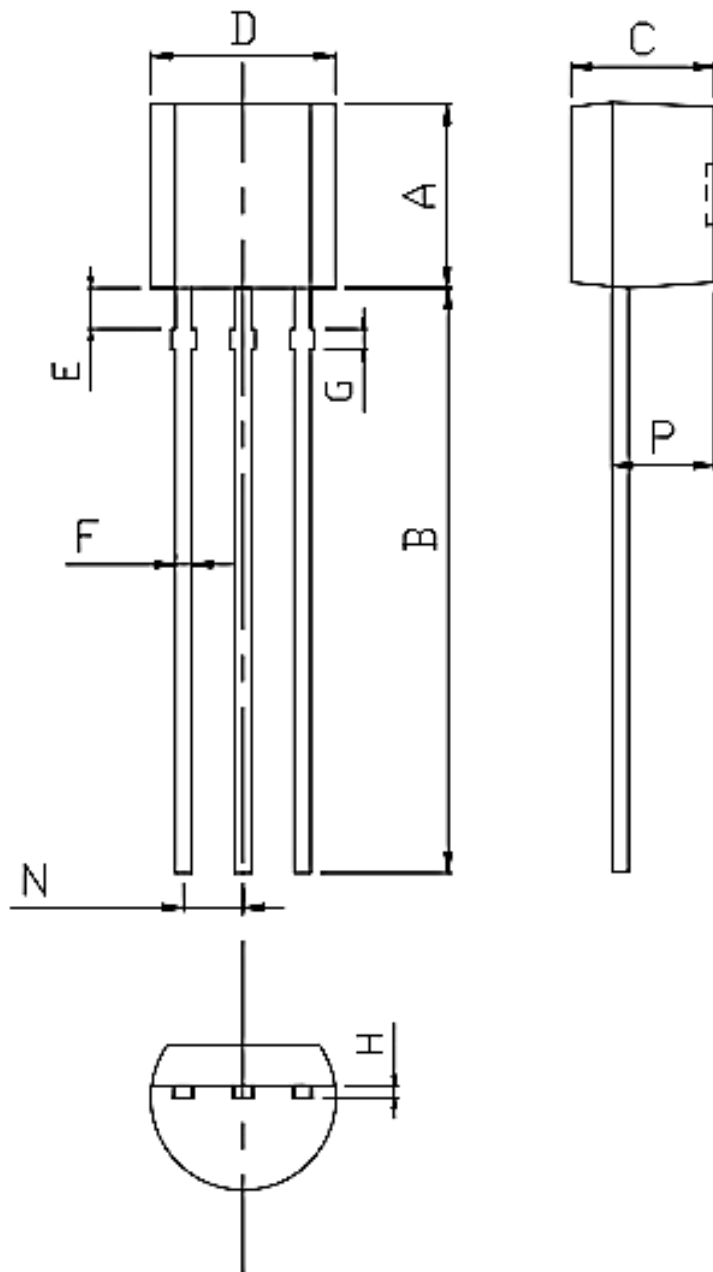

DIM	MILLIMETERS
A	4.55+0.20
B	14.50±0.30
C	3.54±0.20
D	4.56±0.20
E	1.30±0.20
F	0.46±0.20
G	0.50±0.10
H	0.32±0.10
N	1.30±0.20
P	2.52±0.20

Unit (mm)