

1W, 3720, Low Resistance Chip Resistor (Lead free / Halogen Free)

1. Scope

This specification applies to 3.75mm x 2.0mm size 1W, fixed metal film low resistance value chip resistors rectangular type.

2. Type Designation

RL3720WT - - NH

(1) (2) (3) (4)

Where

- (1) Type and size
- (2) Nominal Resistance value:
 Four digits of number
 Refer to paragraph 4-1
 The “ R ” shall be used as a decimal point.
- (3) Resistance tolerance:
 Refer to paragraph 4-1
- (4) NH = Sn plating (Lead free / Halogen free)

3. Construction and Physical Dimensions

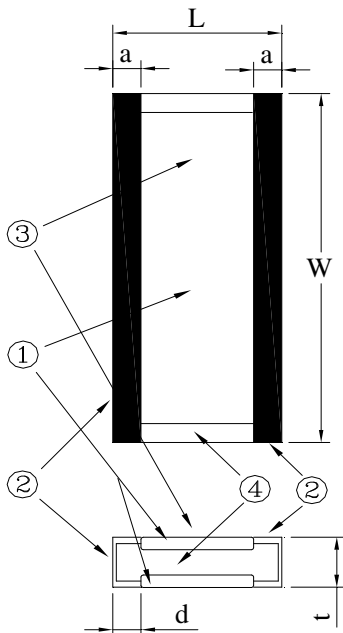

Code Letter	Dimensions (mm)
L	2.00 ± 0.20
W	3.75 ± 0.30
t	0.8 ± 0.2
a	0.40 ± 0.2
d	0.40 ± 0.2

- ① Resistive element : Metal film
(Under protection film)
- ② Electrode : Solder Sn (on Cu)
Sn 100% (Lead free)
- ③ Protection film : Epoxy resin
- ④ Substrate : Alumina

Figure 1. Construction and Dimensions

4. Ratings

4-1 Nominal Resistance Value and Temperature Coefficient of Resistance

Power Rating*	1W
Resistance Value	0.003Ω ~ 0.05Ω
Resistance Tolerance	± 1%(F) , ± 2%(G) , ± 5%(J)
Temperature Coefficient of Resistance	±100ppm/°C

4-2 Rated Voltage

The rated voltage shall be determined by the following expression.

$$V = \sqrt{P \times R}$$

Where V : Rated voltage (V)

R : Nominal resistance value (Ω)

P : Rated dissipation (W)

4-3 Operating and Storage Temperature Range

-55 to +125°C

5. Marking

Resistance value mark on a top surface use four or three digits by JIS.

White bars are Cynotec internal use only.

Example

0.01Ω



0.02Ω

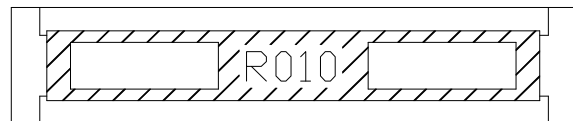

6. Characteristics

Test Item	Condition of Test	Requirements
Short Time Overload	5 * Rated voltage for 5 seconds Refer to JIS C 5201-1 4.13	$\Delta R : \pm (0.5\%+0.0005\Omega)$ Without significant damage by flashover (spark, arching), burning or breakdown etc.
Insulation Resistance	The resistor shall be cramped in the metal block and tested , as shown below. Test voltage : $100 \pm 15V_{DC}$ for 1 minute Refer to JIS C 5201-1 4.6 Mounting condition G.	Between Electrode and Protection Film $100M\Omega$ or over Between Electrode and Substrate $1,000M\Omega$ or over
Voltage Proof	The voltage : $100V_{AC}$ (rms.) for 1 minute Refer to JIS C 5201-1 4.7	$\Delta R : \pm (0.5\%+0.0005\Omega)$ Without damage by flashover, fire or breakdown, as shown below.
Thermal Shock	$-55 \sim 125^{\circ}C$ 5 cycles, 15 min at each extreme condition Refer to JIS C 5201-1 4.19	$\Delta R : \pm (0.5\%+0.0005\Omega)$ Without distinct damage in appearance
Low Temperature Storage	Kept at $-55^{\circ}C$, 1,000 hours Refer to JIS C 5201-1 4.23.4	$\Delta R : \pm (1.0\%+0.0005\Omega)$ Without distinct damage in appearance
High Temperature Exposure	Kept at $125^{\circ}C$ for 1,000 hours Refer to JIS C 5201-1 4.23.2	$\Delta R : \pm (1.0\%+0.0005\Omega)$ Without distinct damage in appearance
Solderability	Temperature of Solder : $245 \pm 5^{\circ}C$ Immersion Duration : 3 ± 0.5 second Refer to JIS C 5201-1 4.17	Uniform coating of solder cover minimum of 95% surface being immersed
Resistance to Soldering Heat	Dipped into solder at $270 \pm 5^{\circ}C$ for 10 ± 1 seconds Refer to JIS C 5201-1 4.18	$\Delta R : \pm (0.5\%+0.0005\Omega)$ Without distinct deformation in appearance

Test Item	Condition of Test	Requirements
Load Life	Rated voltage for 1.5 hours followed by a pause 0.5 hour at $70 \pm 2^{\circ}\text{C}$. Cycle repeated 1000 hours Refer to JIS C 5201-1 4.25	$\Delta R : \pm (1.0\%+0.0005\Omega)$ Without distinct damage in appearance
Damp Heat with Load	$40 \pm 2^{\circ}\text{C}$ with relative humidity 90% to 95%. D.C. rated voltage for 1.5 hours ON and 30 minutes OFF. Cycle repeated 1,000 hours Refer to JIS C 5201-1 4.24	$\Delta R : \pm (1.0\%+0.0005\Omega)$ Without distinct damage in appearance
Mechanical Shock	100 G's for 6milliseconds. 5 pulses Refer to JIS C 5201-1 4.21	$\Delta R : \pm (0.5\%+0.0005\Omega)$ Without mechanical damage such as break
Bending Test	Glass-Epoxy board thickness : 1.6mm Bending width : 2mm Between the fulcrums : 90mm Refer to JIS C 5201-1 4.33	$\Delta R : \pm(0.5\%+0.0005\Omega)$ Without mechanical damage such as break

7. Recommended Solder Pad Dimensions

	W	L	D
3720	4.2	4.0	1.4

Unit : mm

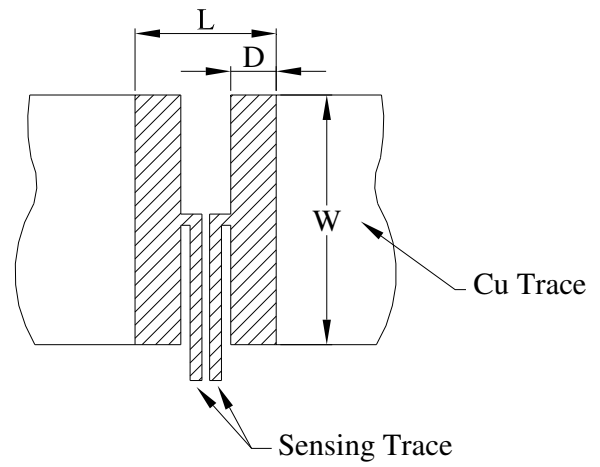

Note : We recommend there is no circuit design
between pads to avoid circuit short

Mounting of the test sample onto the test board shall be either of following methods.

(1) Mounting by solder dipping

Epoxy based glue shall be applied in the middle of two lands of the test board. The resistor shall be mounted in such a way that the electrodes of resistors will be evenly placed in the land area and then adhesive resin shall be cured. After applying the Resin Flux with 25 weight % Methyl Alcohol, the board shall be soldered by dipping into a molten solder bath with $260 \pm 5^{\circ}\text{C}$ for 3 to 5 seconds

(2) Mounting by reflow soldering

Solder paste with approximate $300\mu\text{m}$ thickness shall be applied to the land of test board. The resistor shall be mounted in such way that the electrodes of resistors will be evenly placed in the land area and then shall be soldered under the circumstance that the surface temperature of the board shall be raised $245 \pm 5^{\circ}\text{C}$ (peak) for 3 to 5 seconds in an upper-heater oven.

Test Board

Material : Glass Fabric Epoxy Resin

Board thickness : 1.6mm

Copper foil thickness : 0.035mm

Solder Resist Coating

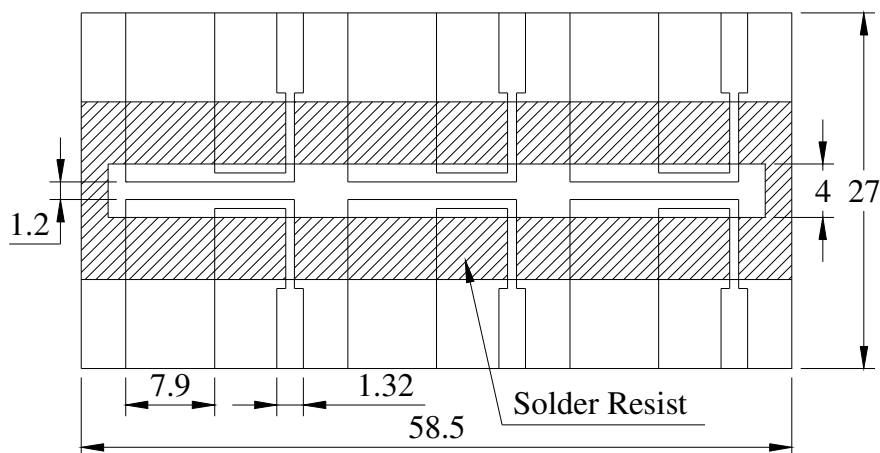

Unit : mm

8. Packaging

8-1 Dimensions

8-1-1 Tape packaging dimensions

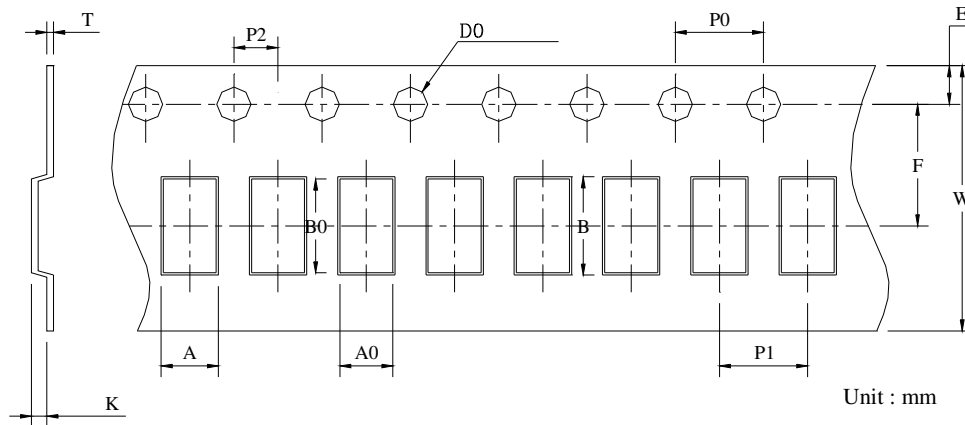

A	2.6 ± 0.2	D0	$\phi 1.55 \pm 0.05$
A0	2.33 ± 0.1	K	1.1 ± 0.1
B	4.3 ± 0.2	T	0.3 ± 0.05
B0	4.1 ± 0.2	P0	4.0 ± 0.1
E	1.75 ± 0.1	P1	4.0 ± 0.1
F	5.5 ± 0.1	P2	2.0 ± 0.2
W	12.0 ± 0.2		

Unit : mm

8-1-2 Reel Dimensions

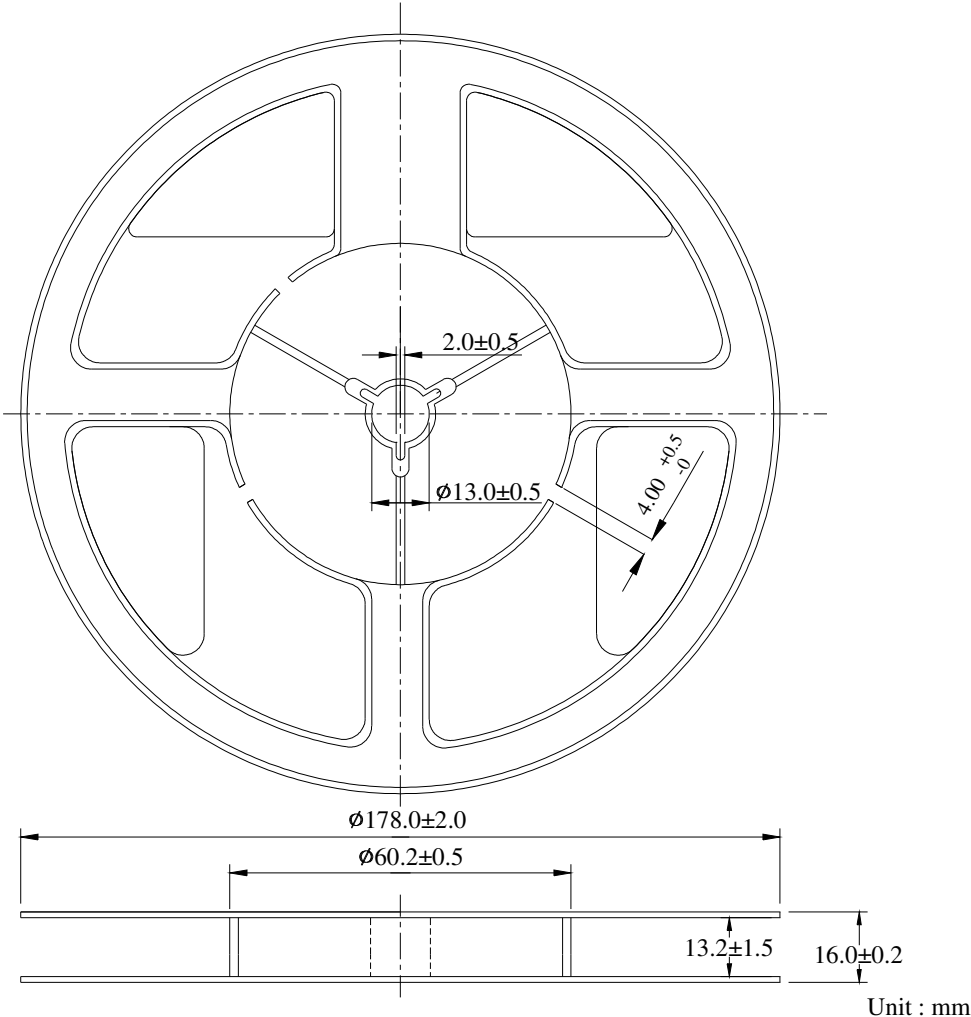

8-2 Peel force of top cover tape

The peel speed shall be about 300 mm/min.

The peel force of top cover tape shall be between 0.1 to 0.7 N

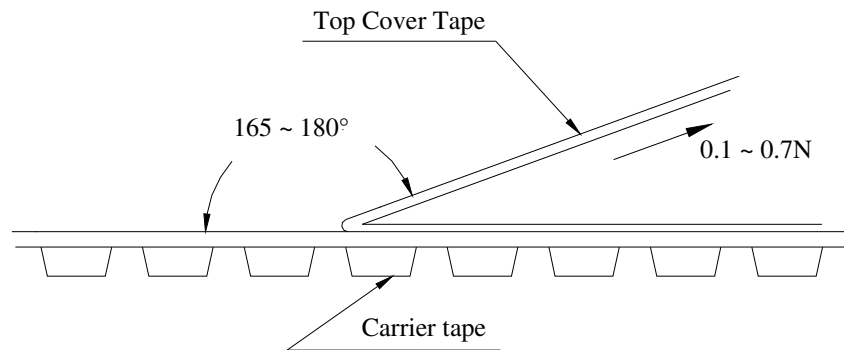

8-3 Numbers of taping

2,000 pieces/reel

8-4 Making

The following items shall be marked on the reel.

- (1) Type designation.
- (2) Quantity
- (3) Manufacturing date code
- (4) Manufacturer's name
- (5) The country of origin