



S07A THRU S07M

PINGWEI ENTERPRISE 1.0 AMP. SURFACE MOUNT GENERAL PURPOSE SILICON RECTIFIERS

FEATURES

- Glass passivated device
- Ideal for surface mounted applications
- Low reverse leakage
- Metallurgically bonded construction
- High temperature soldering guaranteed:
250°C/10 seconds at terminals.

MECHANICAL DATA

- Case: JEDEC SOD-123FL, molded plastic over passivated chip
- Terminals: Solder Plated, solderable per MIL-STD-750, Method 2026
- Polarity: Color band denotes cathode end
- Weight: 0.006 ounces, 0.02 gram
- Mounting position: Any

SOD-123FL

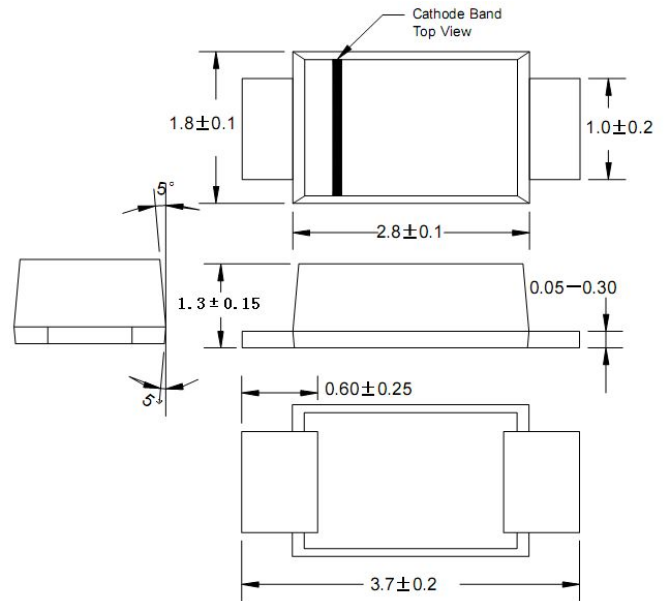

MAXIMUM RATINGS AND ELECTRICAL CHARACTERISTICS

Ratings at 25°C ambient temperature unless otherwise specified.

Single phase, half wave, 60Hz, resistive or inductive load.

For capacitive load, derate current by 20%

Type Number	SYMBOL	S07A	S07B	S07D	S07G	S07J	S07K	S07M	units
	marking	SA	SB	SD	SG	SJ	SK	SM	
Maximum Recurrent Peak Reverse Voltage	V_{RRM}	50	100	200	400	600	800	1000	V
Maximum RMS Voltage	V_{RMS}	35	70	140	280	420	560	700	V
Maximum DC blocking Voltage	V_{DC}	50	100	200	400	600	800	1000	V
Maximum Average Forward rectified Current at $T_A = 65^\circ\text{C}$ (Note 1)	$I_{F(AV)}$	1.0							A
Peak Forward Surge Current 8.3ms single half sine-wave superimposed on rate load (JEDEC method)	I_{FSM}	25							A
Maximum Instantaneous forward Voltage at 1.0A DC	V_F	1.1							V
Maximum DC Reverse Current @ $T_A = 25^\circ\text{C}$ at rated DC blocking voltage @ $T_A = 125^\circ\text{C}$	I_R	5.0 100.0							μA
Typical Junction Capacitance (Note 2)	C_J	4							pF
Typical thermal resistance (Note 3)	$R_{(JA)}$	180							$^\circ\text{C}/\text{W}$
Storage Temperature Range	T_{STG}	-55 to +150							$^\circ\text{C}$
Operation Temperature Range	T_J	-55 to +150							$^\circ\text{C}$

Note:

1. Averaged over any 20 ms period.
2. Measured at 1MHz and applied reverse voltage of 4.0 volts d.c.
3. Measured on P.C. Board with 0.2×0.2”(5.0×5.0mm) Copper Pad Areas

RATING AND CHARACTERISTIC CURVES (S07A THRU S07M)

FIG.1 – TYPICAL FORWARD CHARACTERISTIC

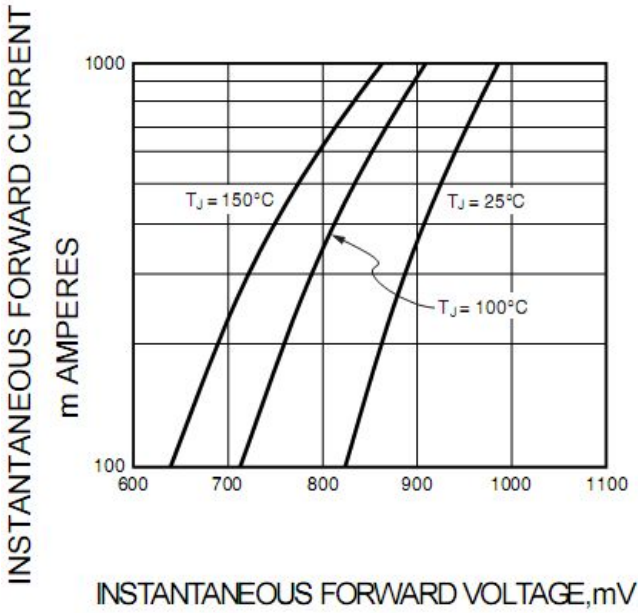

FIG.2 – TYPICAL JUNCTION CAPACITANCE

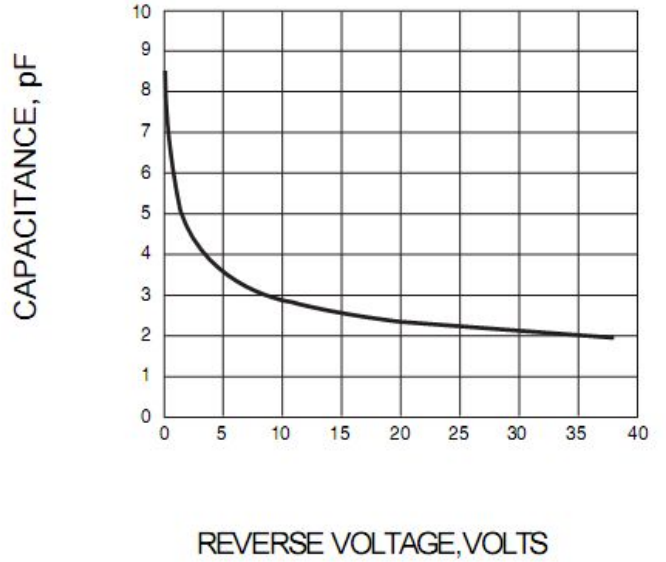

FIG.3 – TYPICAL INSTANTANEOUS REVERSE CHARACTERISTICS

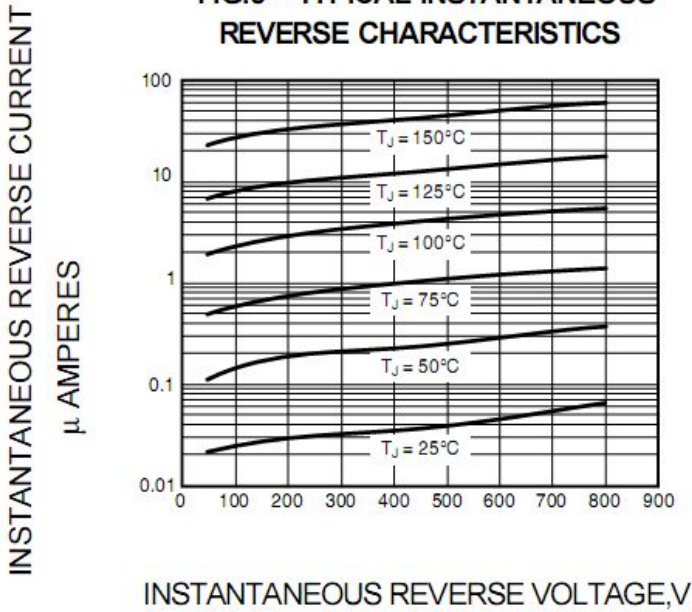

FIG.4 – FORWARD DERATING CURVE

