

13N50MF

13 Amps,500 Volts N-CHANNEL MOSFET

FEATURE

- 13A,500V, $R_{DS(ON)MAX}=0.48\ \Omega$ @ $V_{GS}=10V/6.5A$
- Low gate charge
- Low C_{iss}
- Fast switching
- 100% avalanche tested
- Improved dv/dt capability

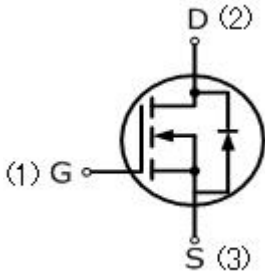

TO-220MF

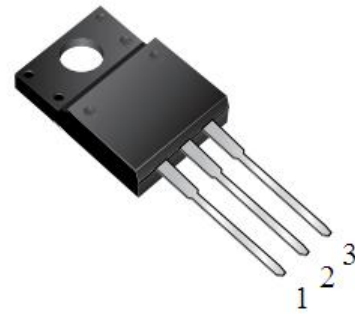

Weight: 2.16 g (typ.)

Absolute Maximum Ratings($T_C=25^\circ C$, unless otherwise noted)

Parameter	Symbol	13N50MF	UNIT
Drain-Source Voltage	V_{DSS}	500	V
Gate-Source Voltage	V_{GSS}	± 30	
Continuous Drain Current	I_D	13	A
Pulsed Drain Current(Note1)	I_{DM}	52	
Single Pulse Avalanche Energy (Note 2)	E_{AS}	630	mJ
Avalanche Current(Note1)	I_{AR}	11.0	A
Reverse Diode dV/dt (Note 3)	dv/dt	3.7	V/ns
Operating Junction and Storage Temperature Range	T_J, T_{STG}	-55 to +150	$^\circ C$
Maximum lead temperature for soldering purposes, 1/8" from case for 5 seconds	T_L	260	$^\circ C$
Mounting Torque	6-32 or M3 screw	10	lbf • in
		1.1	N • m

Parameter	Symbol	13N50MF	Units
Thermal resistance , Channel to Case	$R_{th(ch-c)}$	3.57	$^\circ C/W$
Thermal resistance , Channel to Ambient	$R_{th(ch-a)}$	62.5	$^\circ C/W$
Maximum Power Dissipation	$T_C=25^\circ C$ P_D	35	W

Electrical Characteristics ($T_c=25^\circ\text{C}$, unless otherwise noted)						
Parameter	Symbol	Test Conditions	Min	Typ	Max	Units
Off Characteristics						
Drain-Source Breakdown Voltage	BV_{DSS}	$V_{GS}=0V, I_D=250\mu A$	500	—	—	V
Zero Gate Voltage Drain Current	I_{DSS}	$V_{DS}=500V, V_{GS}=0V$	—	—	1	μA
Gate-Body Leakage Current, Forward	I_{GSSF}	$V_{GS}=30V, V_{DS}=0V$	—	—	100	nA
Gate-Body Leakage Current, Reverse	I_{GSSR}	$V_{GS}=-30V, V_{DS}=0V$	—	—	-100	nA
On Characteristics						
Gate-Source Threshold Voltage	$V_{GS(th)}$	$V_{DS}=V_{GS}, I_D=250\mu A$	2	—	4	V
Drain-Source On-State Resistance	$R_{DS(on)}$	$V_{GS}=10V, I_D=6.5A$	—	0.34	0.48	Ω
Dynamic Characteristics						
Input Capacitance	C_{iss}	$V_{DS}=25V, V_{GS}=0V,$ $f=1.0\text{MHZ}$	—	1630	—	pF
Output Capacitance	C_{oss}		—	202	—	pF
Reverse Transfer Capacitance	C_{rss}		—	32	—	pF
Switching Characteristics						
Turn-On Delay Time	$t_{d(on)}$	$V_{DD}=300V, I_D=0.5A,$ $R_G=25\Omega, V_{GS}=10V,$ (Note3,4)	—	14	—	ns
Turn-On Rise Time	t_r		—	27	—	ns
Turn-Off Delay Time	$t_{d(off)}$		—	45	—	ns
Turn-Off Fall Time	t_f		—	36	—	ns
Total Gate Charge	Q_g	$V_{DS}=50V, I_D=1.3A,$ $V_{GS}=10V, I_D=100\mu A$ (Note3,4)	—	14	—	nC
Gate-Source Charge	Q_{gs}		—	13	—	nC
Gate-Drain Charge	Q_{gd}		—	33	—	nC
Drain-Source Body Diode Characteristics and Maximum Ratings						
Continuous Diode Forward Current	I_S		—	—	13	A
Pulsed Diode Forward Current	I_{SM}		—	—	52	A
Diode Forward Voltage	V_{SD}	$I_S=13A, V_{GS}=0V$	—	—	1.5	V
Reverse Recovery Time	t_{rr}	$V_{GS}=0V, I_S=13A, T_J=150^\circ\text{C}$ $dI_F/dt=100A/\mu s, \text{ (Note3)}$	—	350	—	ns
Reverse Recovery Charge	Q_{rr}		—	4.5	—	μC

Notes

1. Repetitive Rating: pulse width limited by maximum junction temperature.
2. $L=10\text{mH}, I_D=11A$, starting $T_J=25^\circ\text{C}$.
3. $I_{SD} \leq I_D, dI/dt=200A/\mu s, V_{DD} \leq BV_{DSS}$, starting $T_J=25^\circ\text{C}$, Pulse width $\leq 300\mu s$; duty cycle $\leq 2\%$.
4. Repetitive rating; pulse width limited by maximum junction temperature.

TEST CIRCUIT AND WAVEFORM



Peak Diode Recovery dv/dt Test Circuit

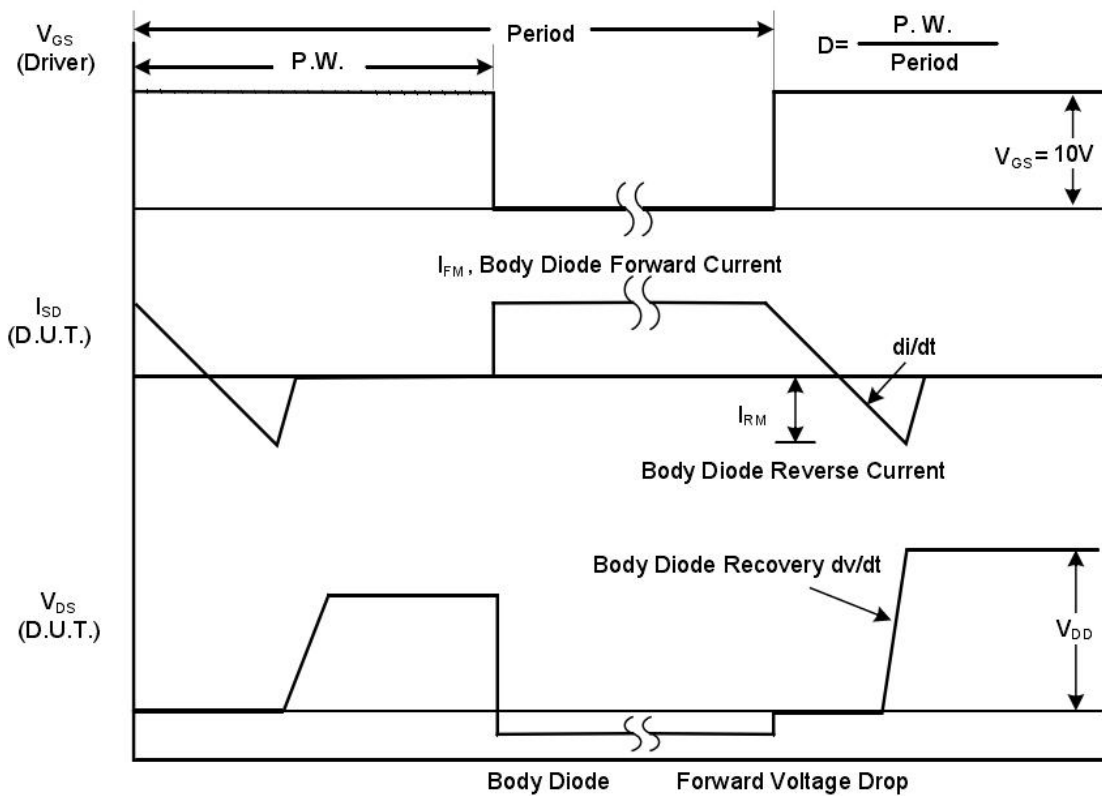

Peak Diode Recovery dv/dt Waveforms

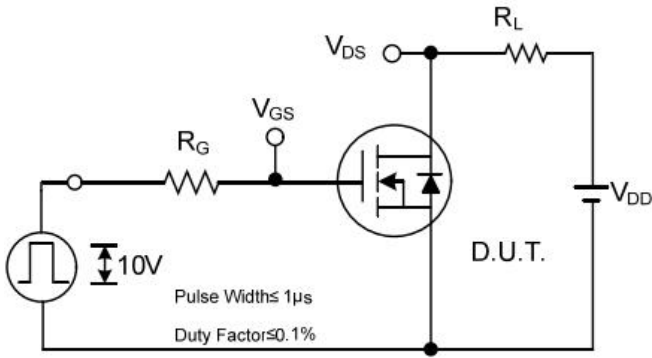

Switching Test Circuit

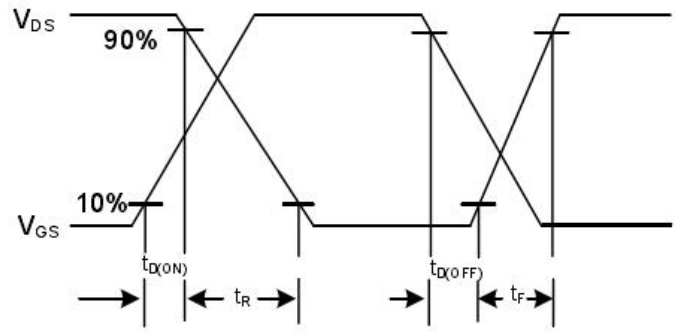

Switching Waveforms

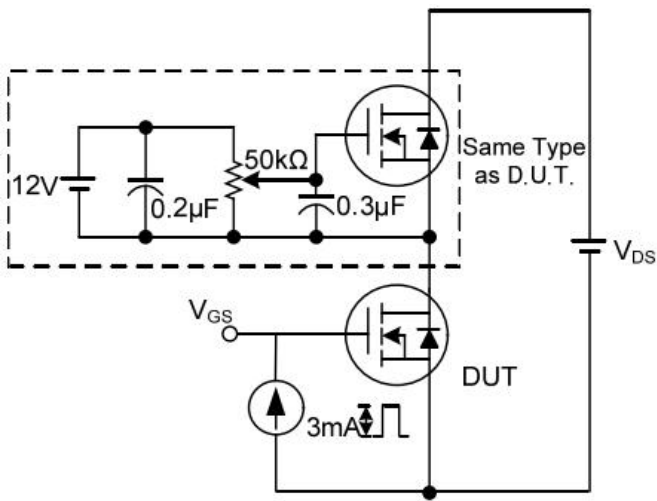

Gate Charge Test Circuit

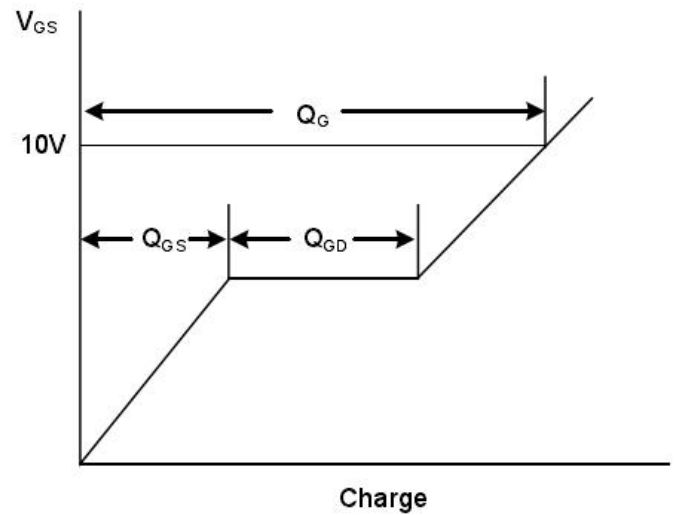

Gate Charge Waveform

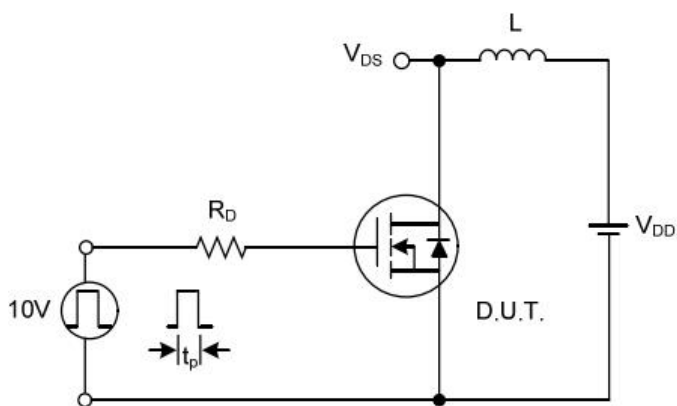

Unclamped Inductive Switching Test Circuit

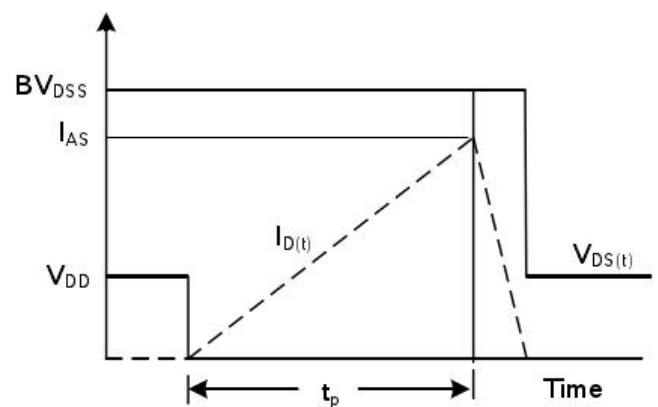

Unclamped Inductive Switching Waveforms

RATING AND CHARACTERISTIC CURVES

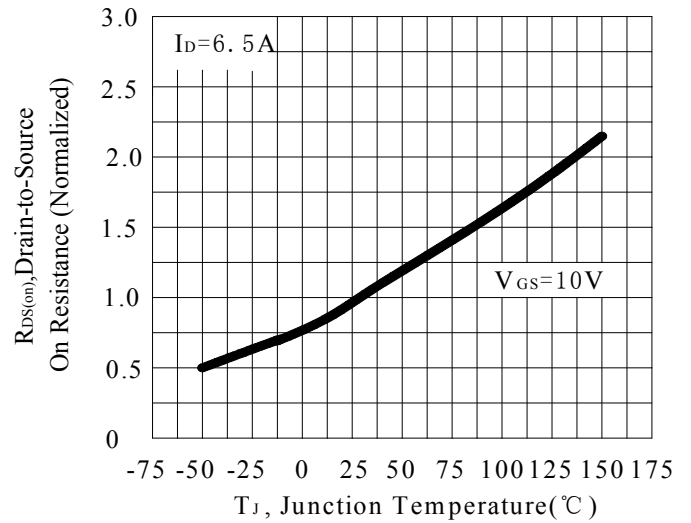
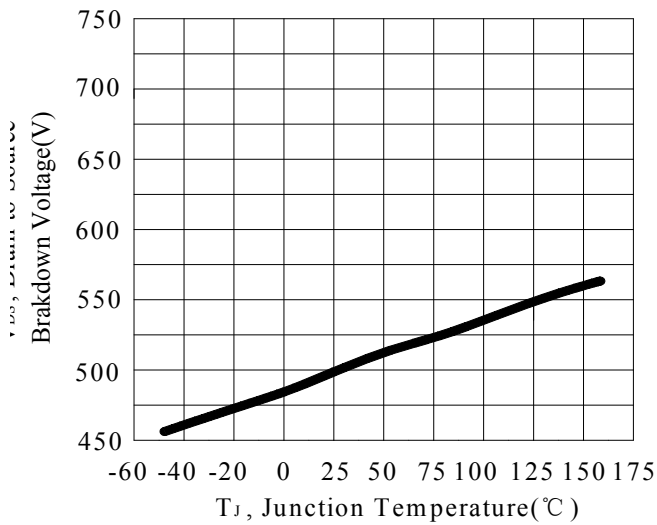
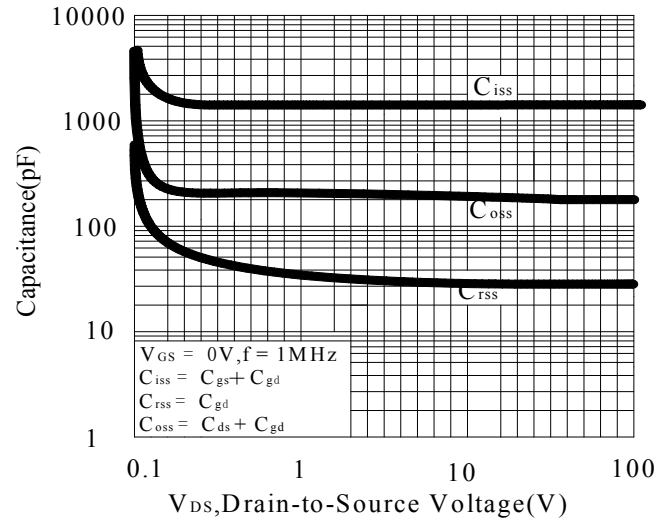
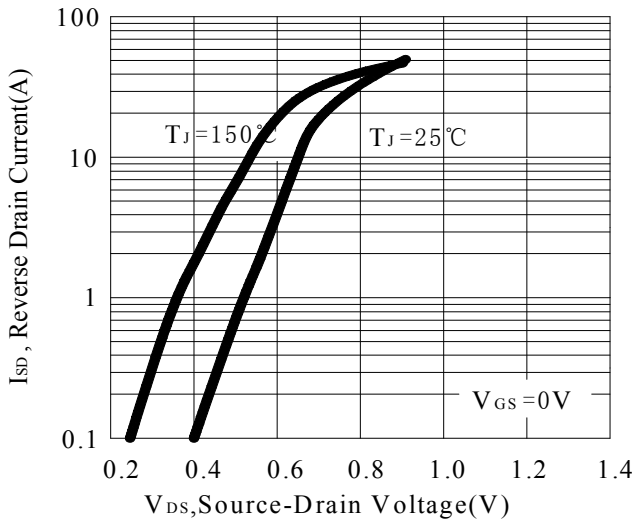
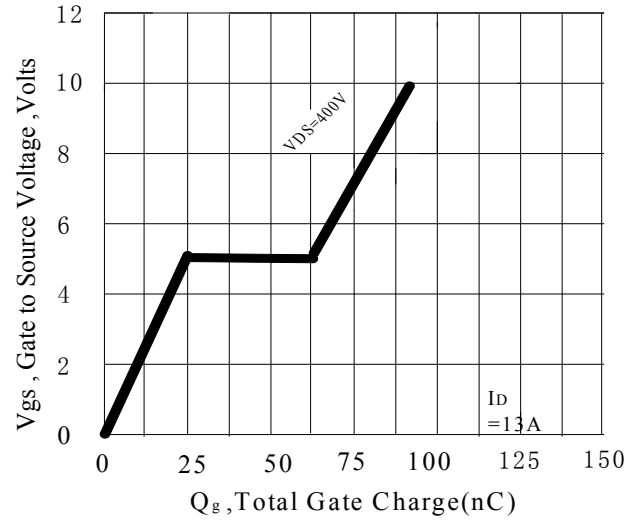
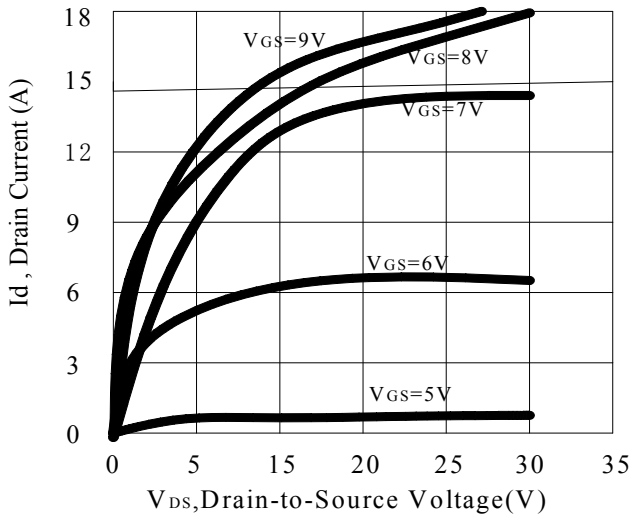

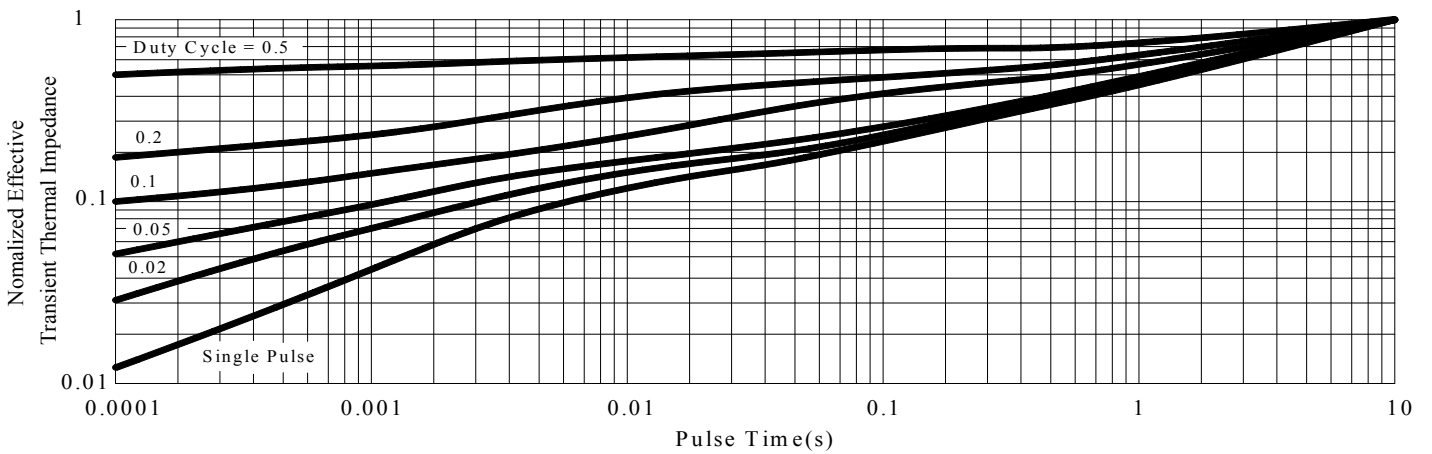
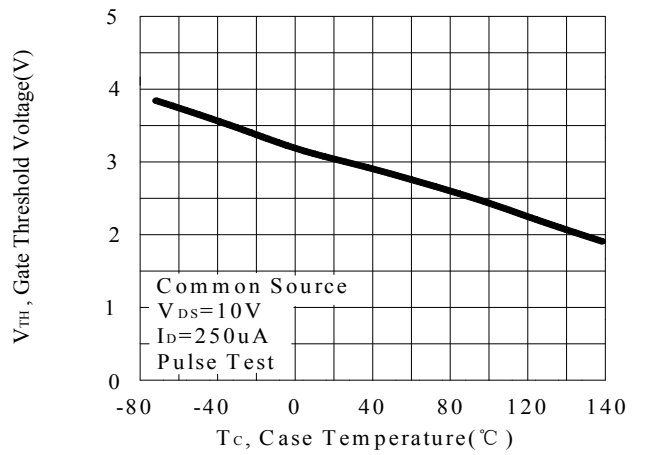
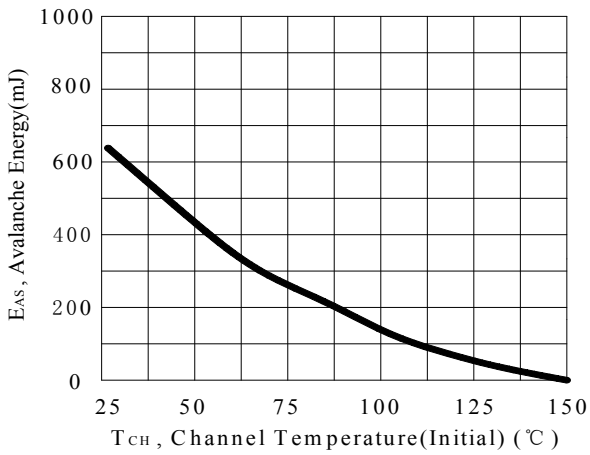
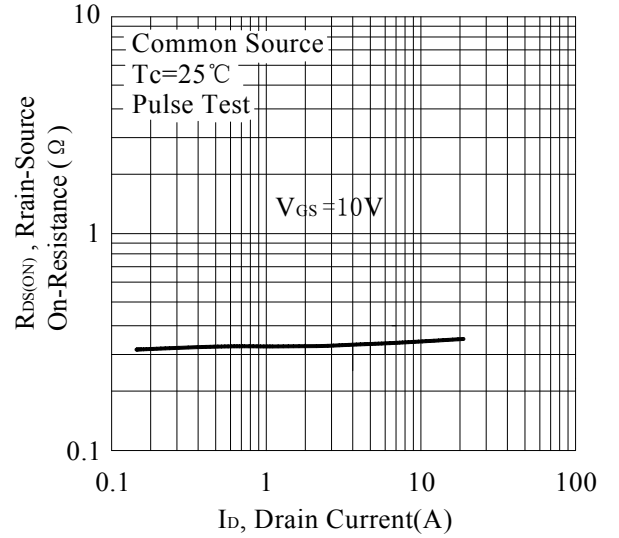
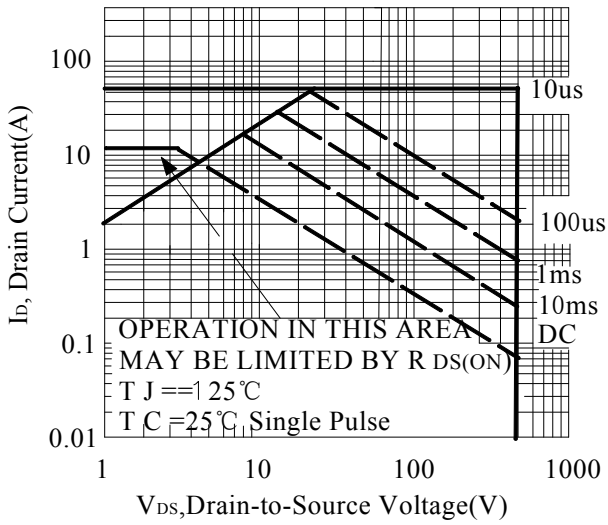

PACKAGE OUTLINE DIMENSIONS

TO-220MF

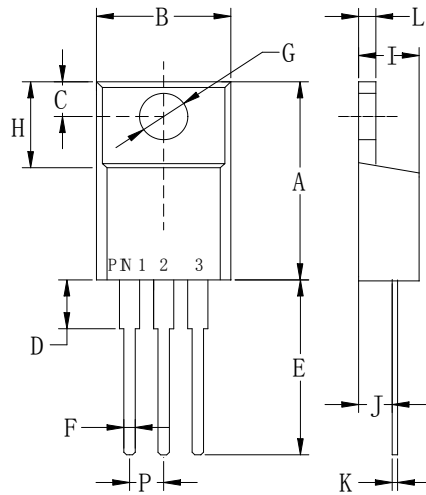

TO-220MF		
Dim	Min	Max
A	.590 (15.0)	.650 (16.5)
B	.393 (10.0)	.414 (10.5)
C	.118 (3.00)	.138 (3.50)
D	.118 (3.00)	.146 (3.70)
E	.512 (13.0)	.551 (14.0)
F	.028 (0.70)	.035 (0.90)
G	.114 (2.90)	.138 (3.50)
H	.255 (6.50)	.280 (7.10)
I	.173 (4.40)	.197 (5.00)
J	.102 (2.60)	.110 (2.80)
K	.018 (0.45)	.026 (0.65)
L	.092 (2.35)	.109 (2.75)
P	.890 (2.25)	.113 (2.85)