

REV	DESCRIPTION	DATE	ECN NO.	CHANGER
A-0	New Released	16.05.12		何 娜
A-1	Modify the shield	16.06.13		何 娜

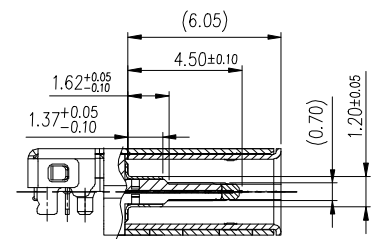

SECTION A-A
SCALE 1:1

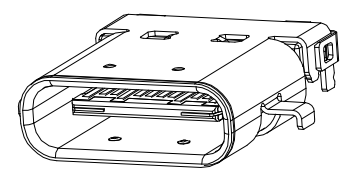
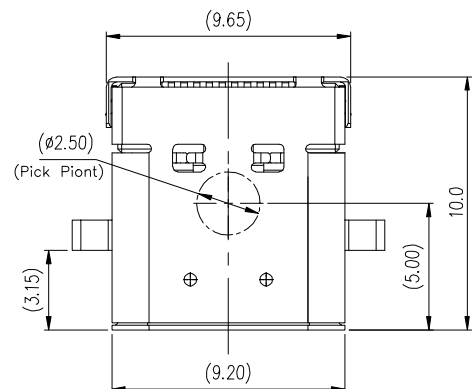
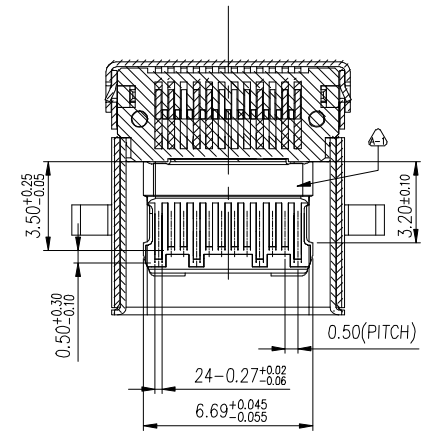

SECTION B-B

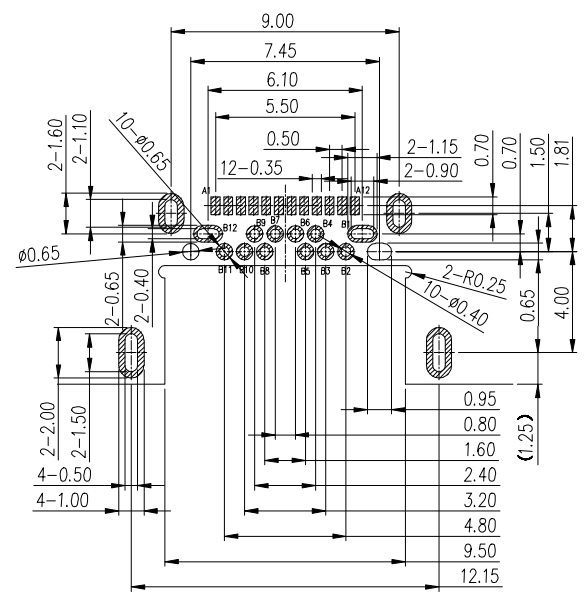

RECOMMEND P.C.B LAYOUT (COMPONENT SIDE)
TOLERANCE: ±0.05

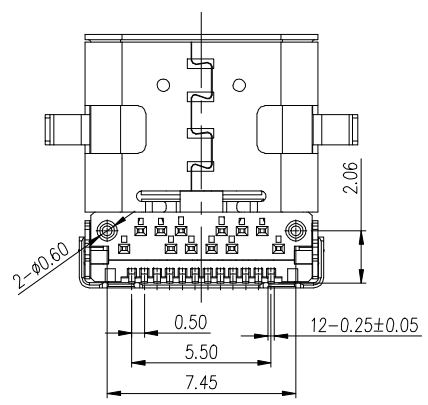
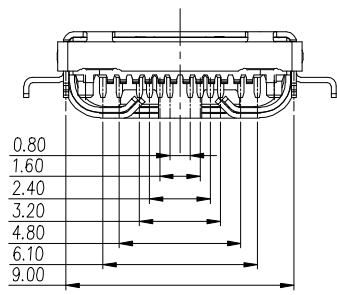
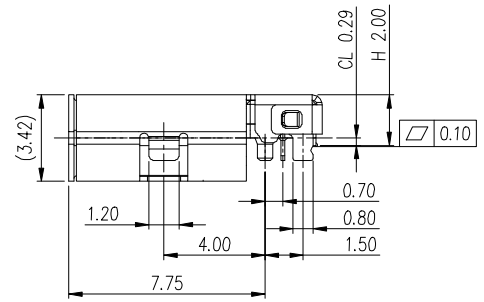
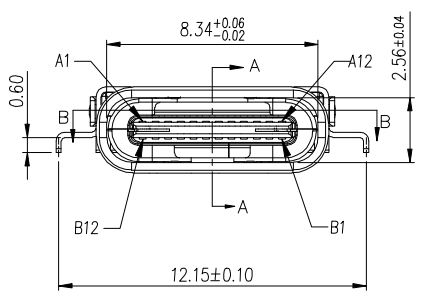

A12	GND	B1	GND
A11	SSRXp2	B2	SSTXp2
A10	SSRXn2	B3	SSTXn2
A9	VBUS	B4	VBUS
A8	SBU1	B5	CC2
A7	Dn1	B6	Dp2
A6	Dp1	B7	Dn2
A5	CC1	B8	SBU2
A4	VBUS	B9	VBUS
A3	SSTXn1	B10	SSRXn1
A2	SSTXp1	B11	SSRXp1
A1	GND	B12	GND
Pin NO.	Signal name	Pin NO.	Signal name

- NOTE:
- MATERIAL:
 - INSULATOR: HIGH TEMPERATURE PLASTIC UL94 V-0; Black Color
 - CONTACT: COPPER ALLOY. GOLD/Matte Tin PLATED.
 - OUTER SHELL: STAINLESS STEEL, Nickel PLATED.
 - INNER SHELL: STAINLESS STEEL, Nickel PLATED.
 - GROUND SHIELD: STAINLESS STEEL, Nickel PLATED.
 - MID PLATE: STAINLESS STEEL, Nickel PLATED.
 - ELECTRICAL CHARACTERISTICS:
 - CONTACT RESISTANCE: 40mΩ Max FOR INITIAL. 10mΩ CHANGE AFTER DURABILITY TEST
 - CONTACT CURRENT RATING: 5A
 - DIELECTRIC WITHSTANDING VOLTAGE: 100V AC R.M.S.
 - INSULATION RESISTANCE 100MΩ Min
 - OPERATING TEMPERATURE: -40°C ~ 80°C
 - MECHANICAL CHARACTERISTICS:
 - MATING FORCE: 5~20 N.
 - UNMATED FORCE: INITIAL 8~20N; 6~20N AFTER DURABILITY TEST
 - DURABILITY: 10,000 CYCLES

CZT[®] DONGGUAN ZHENGDE (YIHUA) CONNECTOR CO., LTD

10317224F001	LCP, Black, 30U/Matte tin	X. ±0.38 .X ±0.25 .XX±0.20 .XXX±0.10	X.' ±4' .X' ±2' .XX' .XXX'	UNIT: mm 3RD:	DR: Hena DE: Great	TITLE: USB TYPE C Female Connector H=2.0mm, CL=0.29mm
10317224D002	LCP, Black, 15U/Matte tin			SCALE: 1:1	CHKD:	SHEET: 1/1
10317224A001	LCP, Black, FU/Matte tin			REV: A-1	APPD:	P/N: SEE TABLE
PART NUMBER	REMARK	CUSTOMER DRAWING		D/N: 131A-0007	M/N:	