



DC Input 4-Pin Mini-Flat High BV_{CEO} Photo Darlington Optocoupler

Features

- High isolation 3750 VRMS
- CTR : Min 1000%
- High $BV_{CEO} = 350V$
- Operating temperature range - 55 °C to 100 °C
- Green Package
- Regulatory Approvals
 - UL - UL1577 (E364000)
 - VDE - EN60747-5-5(VDE0884-5)
 - CQC – GB4943.1, GB8898
 - IEC60065, IEC60950

Description

The CT452 consists of a high power photodarlington transistor optically coupled to a gallium arsenide Infrared-emitting diode in a 4-lead Mini-Flat package.

Applications

- Switch mode power supplies
- Computer peripheral interface
- Microprocessor system interface

Package Outline

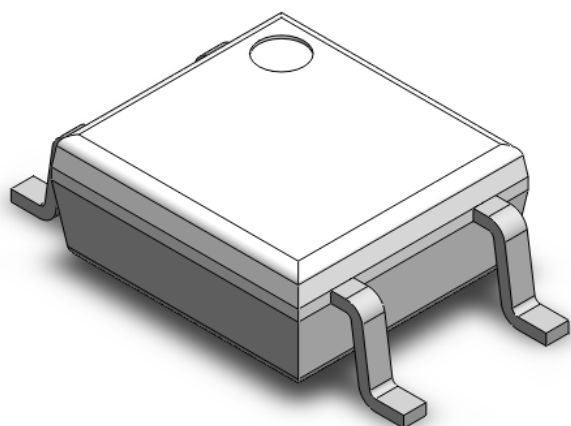

Schematic

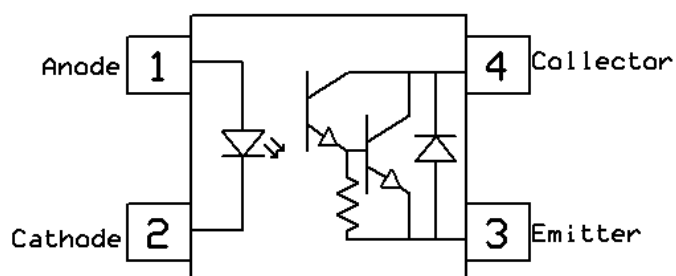

Note: Different lead forming options available. See package dimension.



DC Input 4-Pin Mini-Flat High BV_{CEO} Photo Darlington Optocoupler

Absolute Maximum Rating at 25°C

<i>Symbol</i>	<i>Parameters</i>	<i>Ratings</i>	<i>Units</i>	<i>Notes</i>
V _{ISO}	Isolation voltage	3750	V _{RMS}	
T _{OPR}	Operating temperature	-55 ~ +100	°C	
T _{STG}	Storage temperature	-55 ~ +125	°C	
T _{SOL}	Soldering temperature	260	°C	
P _{TOT}	Total power dissipation	170	mW	
Emitter				
I _F	Forward current	60	mA	
I _{F(TRANS)}	Peak transient current (≤1μs P.W,300pps)	1	A	
V _R	Reverse voltage	6	V	
P _C	Power dissipation	150	mW	
Detector				
P _D	Power dissipation	150	mW	
B _{VCEO}	Collector-Emitter Breakdown Voltage	350	V	
B _{VECO}	Emitter-Collector Breakdown Voltage	0.1	V	
I _C	Collector Current	150	mA	



DC Input 4-Pin Mini-Flat High BV_{CEO} Photo Darlington Optocoupler

Electrical Characteristics

$T_A = 25^\circ\text{C}$ (unless otherwise specified)

Emitter Characteristics

Symbol	Parameters	Test Conditions	Min	Typ	Max	Units	Notes
V_F	Forward voltage	$I_F=10\text{mA}$		1.24	1.4	V	
I_R	Reverse Current	$V_R = 5\text{V}$	-	-	5	μA	
C_{IN}	Input Capacitance	$f=1\text{MHz}$	-	15	-	pF	

Detector Characteristics

Symbol	Parameters	Test Conditions	Min	Typ	Max	Units	Notes
BV_{CEO}	Collector-Emitter Breakdown	$I_C=100\mu\text{A}$	350	-	-	V	
BV_{ECO}	Emitter-Collector Breakdown	$I_E=100\mu\text{A}$	0.1	-	-	V	
I_{CEO}	Collector-Emitter Dark Current	$V_{CE}=200\text{V}, I_F=0\text{mA}$	-	-	100	nA	

Transfer Characteristics

Symbol	Parameters	Test Conditions	Min	Typ	Max	Units	Notes
CTR	Current Transfer Ratio	$I_F=1\text{mA}, V_{CE}=2\text{V}$	1000		15000	%	
$V_{CE(SAT)}$	Collector-Emitter Saturation Voltage	$I_F=20\text{mA}, I_C=100\text{mA}$	-	-	1.2	V	
R_{IO}	Isolation Resistance	$V_{IO}=500\text{V}_{DC}$	5×10^{10}			Ω	
C_{IO}	Isolation Capacitance	$f=1\text{MHz}$		0.6		pF	

Switching Characteristics

Symbol	Parameters	Test Conditions	Min	Typ	Max	Units	Notes
t_r	Rise Time	$I_C=2\text{mA}, V_{CE}=2\text{V}, R_L=100\Omega$	-	-	250	μs	
t_f	Fall Time		-	-	95		



DC Input 4-Pin Mini-Flat High BV_{CE0} Photo Darlington Optocoupler

Typical Characteristic Curves

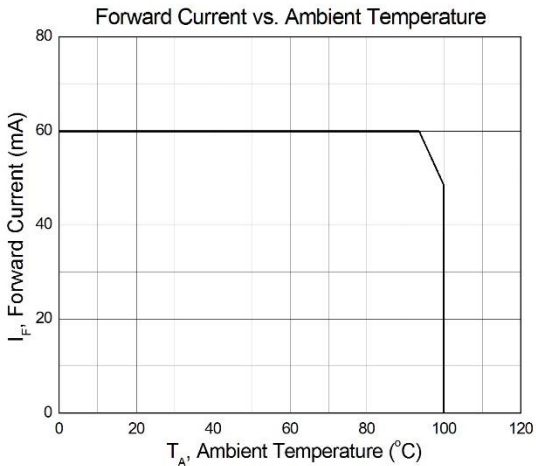

Figure 1

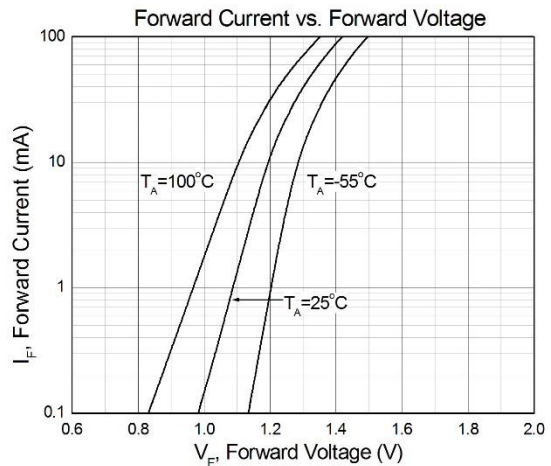

Figure 2

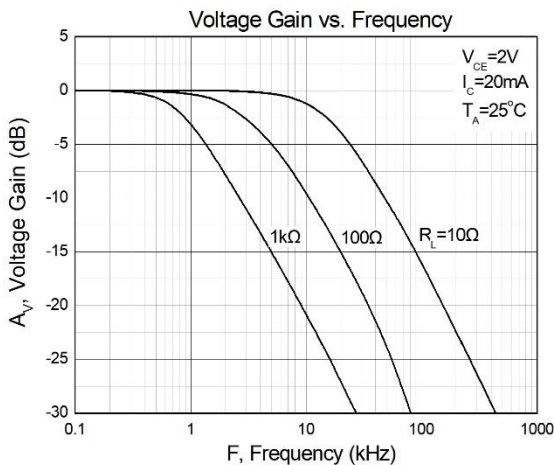

Figure 3

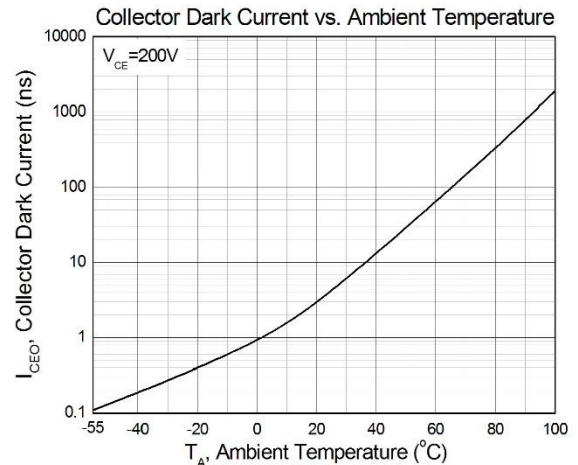

Figure 4

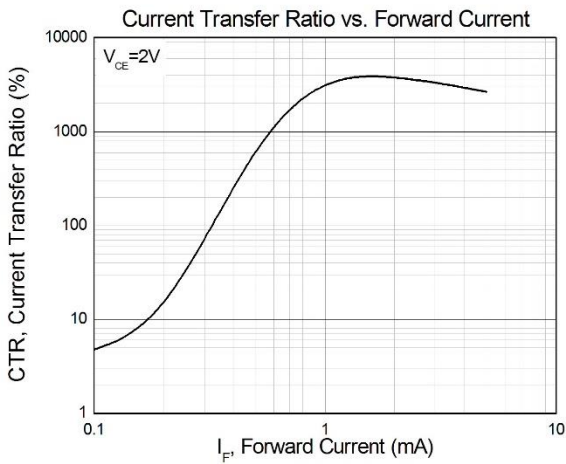

Figure 5

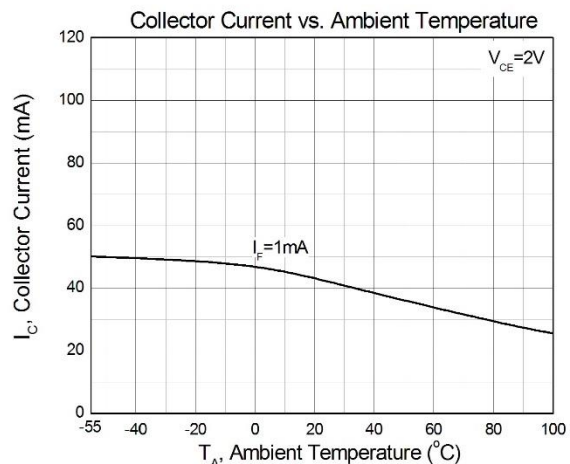

Figure 6



DC Input 4-Pin Mini-Flat High BV_{CE0} Photo Darlington Optocoupler

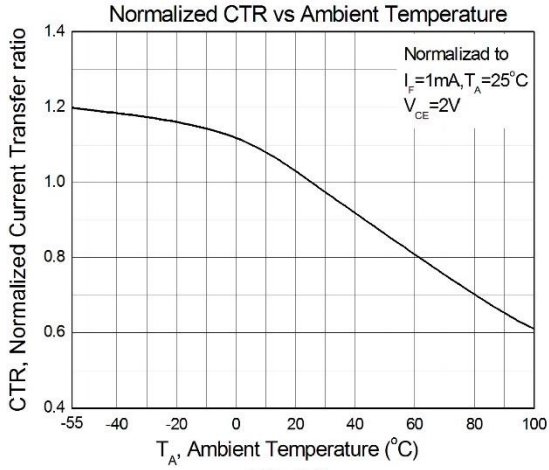

Figure 7

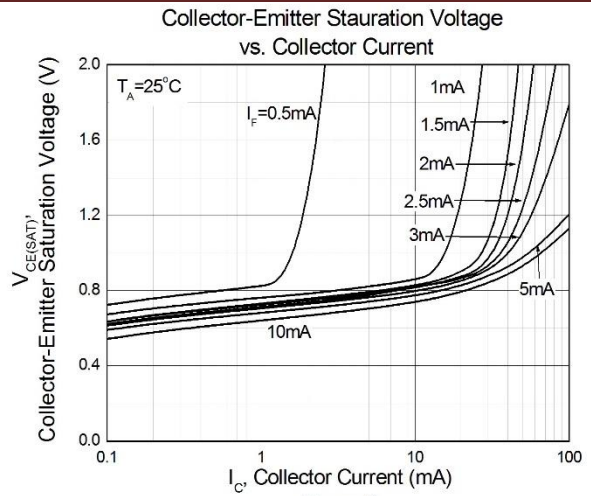

Figure 8

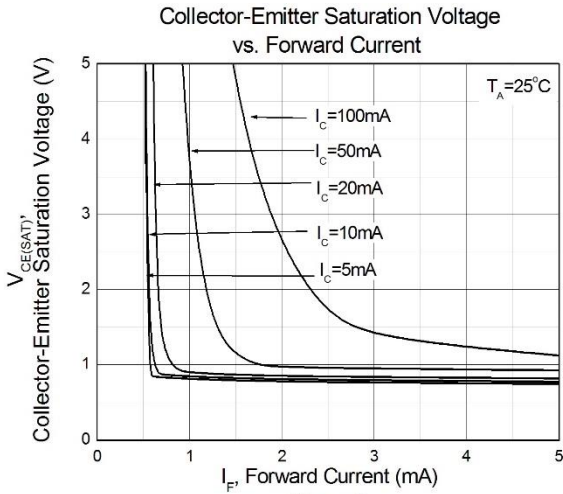

Figure 9

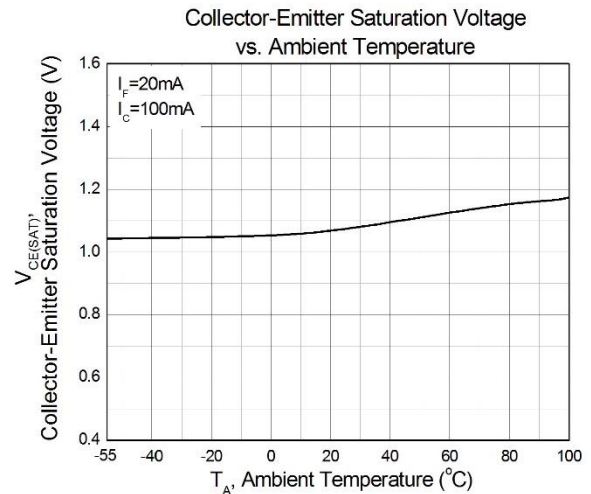

Figure 10

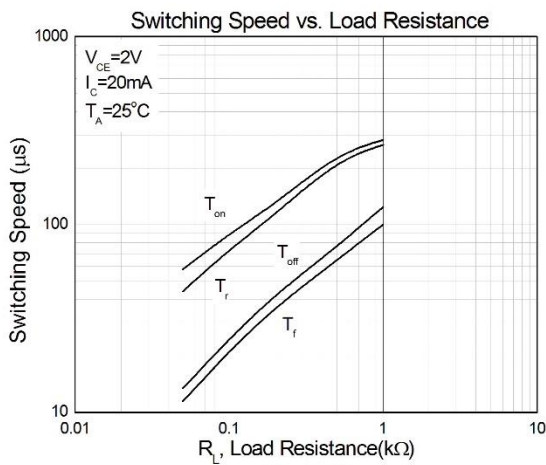
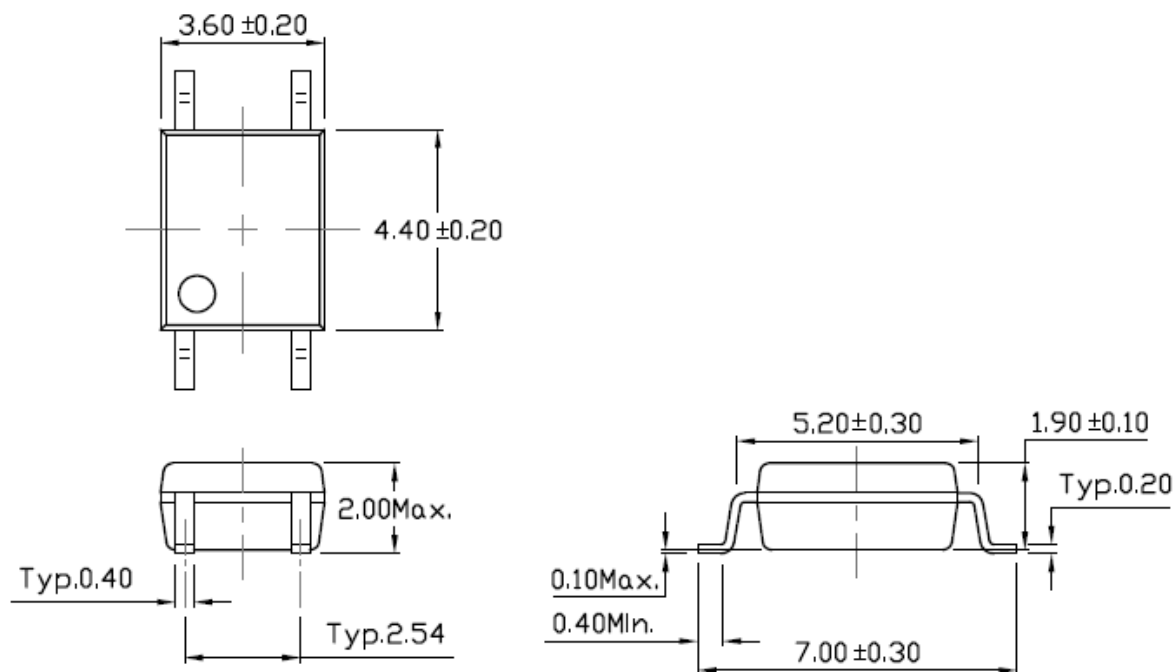

Figure 11



DC Input 4-Pin Mini-Flat High BV_{CEO} Photo Darlington Optocoupler

Package Dimension *Dimensions in mm unless otherwise stated*



Recommended Solder Mask *Dimensions in mm unless otherwise stated*

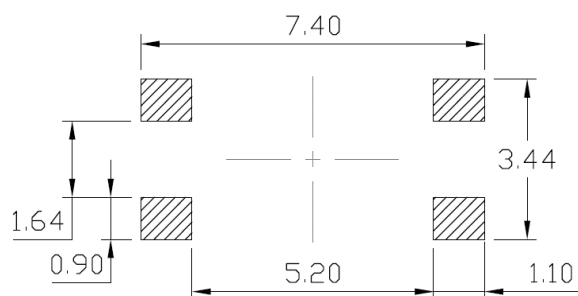



CT452

DC Input 4-Pin Mini-Flat
High BV_{CEO} Photo Darlington Optocoupler

Marking Information

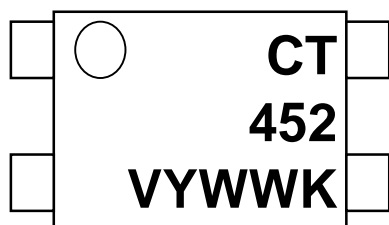

Note:

CT : Denotes “CT Micro”

452 : Product Number

V : VDE Option

Y : Fiscal Year

WW : Work Week

K : Manufacturing Code

Ordering Information

CT452(V)(Z)

V = VDE option (V or None)

Z = Tape and reel option (T1, or T2)

Option	Description	Quantity
T1	Surface Mount Lead Forming – With Option 1 Taping	3000 Units/Reel
T2	Surface Mount Lead Forming – With Option 2 Taping	3000 Units/Reel



DC Input 4-Pin Mini-Flat
High BV_{CEO} Photo Darlington Optocoupler

Carrier Tape Specifications *Dimensions in mm unless otherwise stated*

Option T1

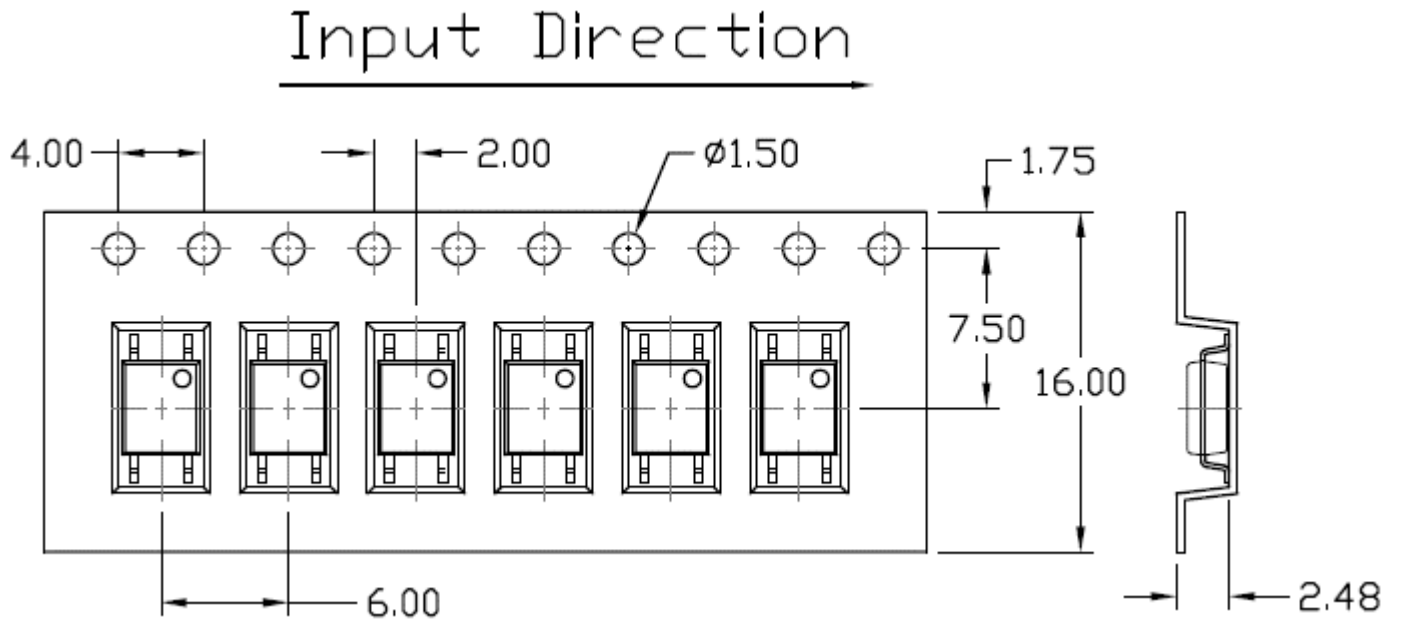

Option T2

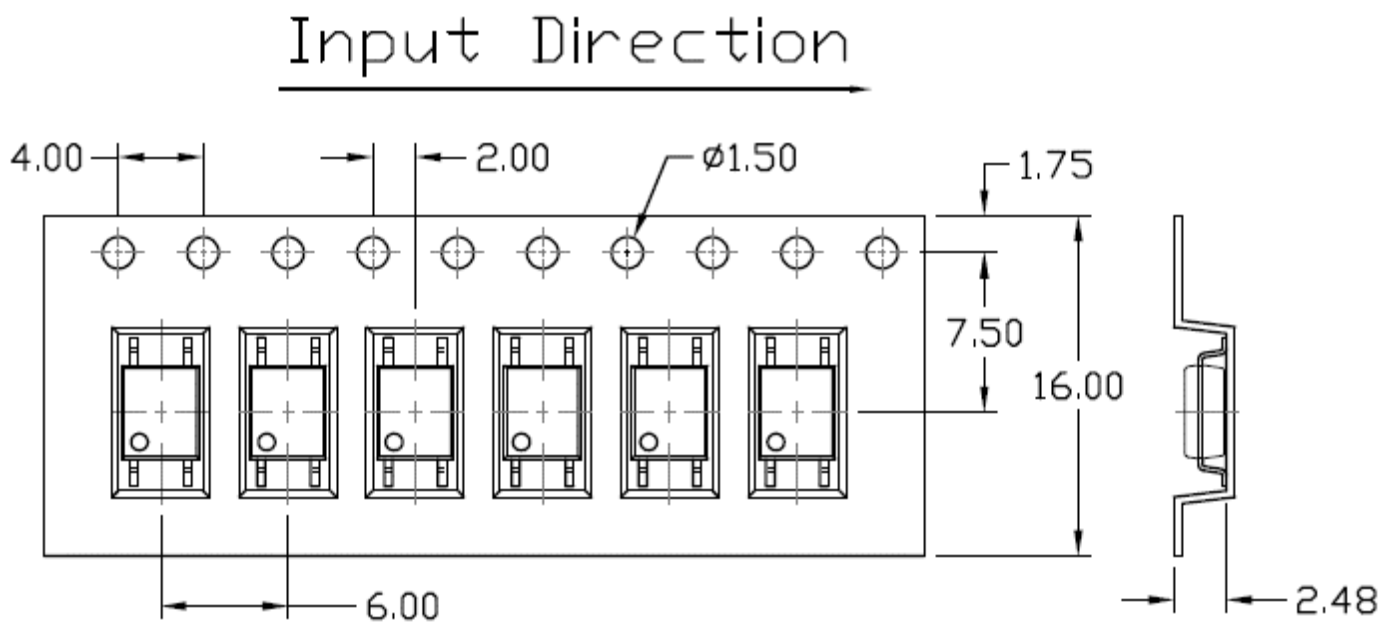



DC Input 4-Pin Mini-Flat High BV_{CEO} Photo Darlington Optocoupler

Reflow Profile

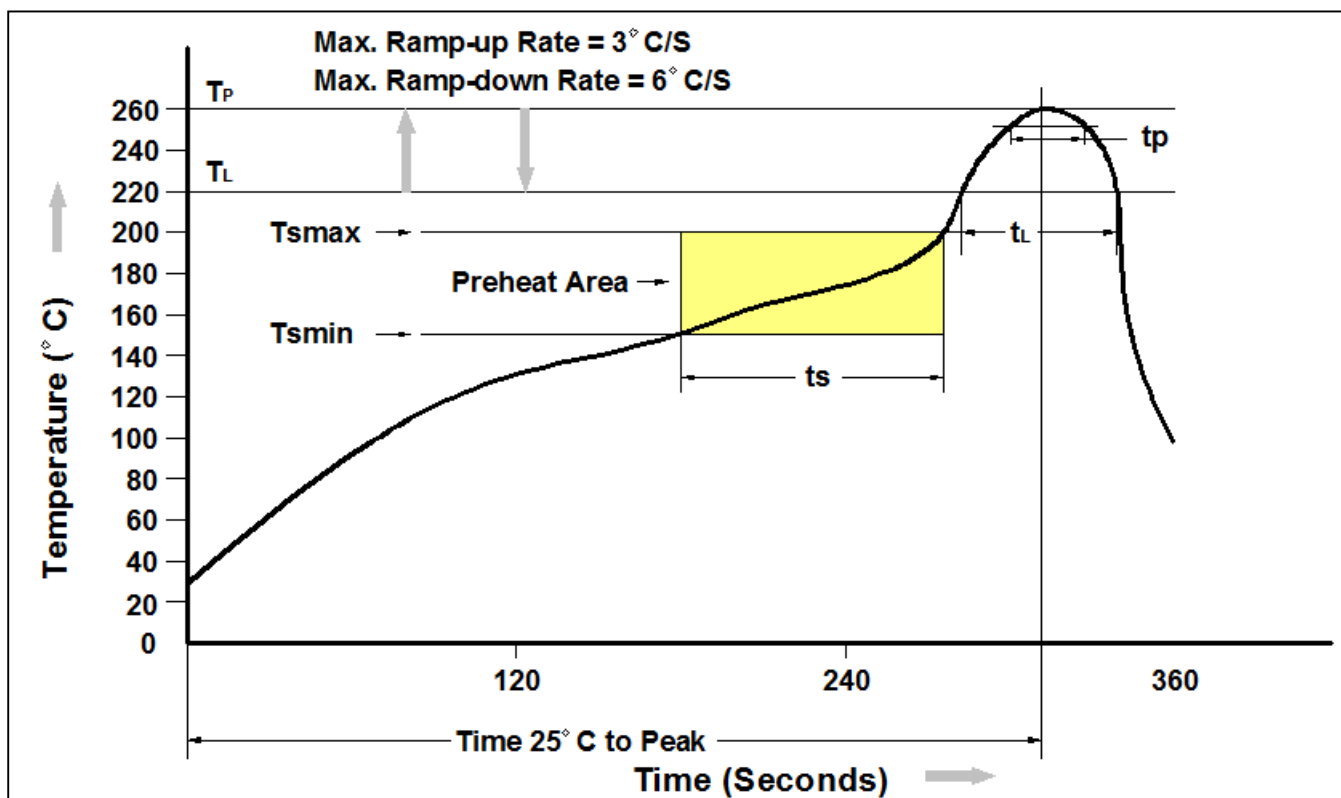

Profile Feature	Pb-Free Assembly Profile
Temperature Min. (T _{smin})	150°C
Temperature Max. (T _{smax})	200°C
Time (t _s) from (T _{smin} to T _{smax})	60-120 seconds
Ramp-up Rate (t _L to t _P)	3°C/second max.
Liquidous Temperature (T _L)	217°C
Time (t _L) Maintained Above (T _L)	60 – 150 seconds
Peak Body Package Temperature	260°C +0°C / -5°C
Time (t _P) within 5°C of 260°C	30 seconds
Ramp-down Rate (T _P to T _L)	6°C/second max
Time 25°C to Peak Temperature	8 minutes max.



DC Input 4-Pin Mini-Flat High BV_{CEO} Photo Darlington Optocoupler

DISCLAIMER

CT MICRO RESERVES THE RIGHT TO MAKE CHANGES WITHOUT FURTHER NOTICE TO ANY PRODUCTS HEREIN TO IMPROVE RELIABILITY, FUNCTION OR DESIGN. CT MICRO DOES NOT ASSUME ANY LIABILITY ARISING OUT OF THE APPLICATION OR USE OF ANY PRODUCT OR CIRCUIT DESCRIBED HEREIN; NEITHER DOES IT CONVEY ANY LICENSE UNDER ITS PATENT RIGHTS, NOR THE RIGHTS OF OTHERS.

DISCOLORATION MIGHT OCCUR ON THE PACKAGE SURFACE AFTER SOLDERING, REFLOW OR LONG TERM USE. THIS DOES NOT IMPACT THE PRODUCT PERFORMANCE NOR THE PRODUCT RELIABILITY.

CT MICRO ARE NOT AUTHORIZED FOR USE AS CRITICAL COMPONENTS IN LIFE SUPPORT DEVICES OR SYSTEMS WITHOUT EXPRESS WRITTEN APPROVAL OF CT MICRO INTERNATIONAL CORPORATION.

- 1. Life support devices or systems are devices or systems which, (a) are intended for surgical implant into the body, or (b) support or sustain life, or (c) whose failure to perform when properly used in accordance with instruction for use provided in the labelling, can be reasonably expected to result in significant injury to the user.*
- 2. A critical component is any component of a life support device or system whose failure to perform can be reasonably expected to cause the failure of the life support device or system, or to affect its safety or effectiveness.*