

A-A (2.5 : 1)

NOTE:

1. SOLDERTAIL TO BE WITHIN 0.05 UPWARD AND 0.2 DOWNWARD FROM Z-DATUM PLACE, AND COPLANALITY OF SOLDERTAILS TO BE WITHIN 0.10. MEASUREMENT POINT IS SOLDERTAILS TIP.
2. INSPECTION SYMBOL:  
 : MANUFACTURER INSPECTION  
 : Q.C INSPECTION

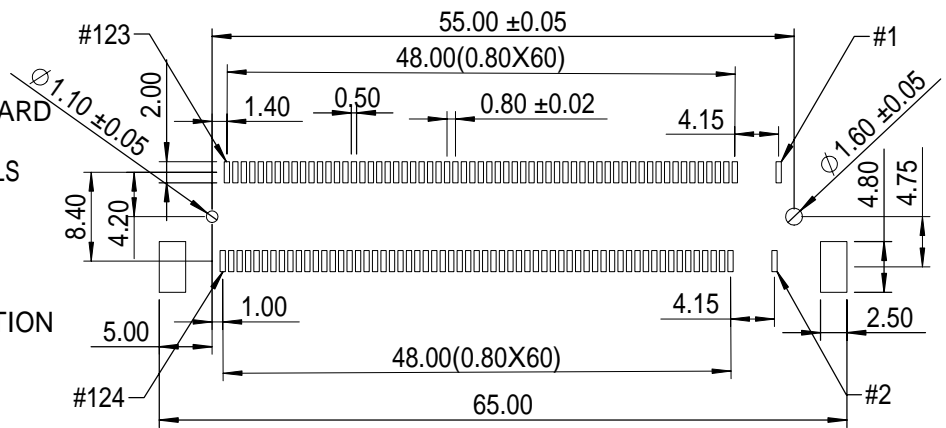

PCB LAYOUT

				GENERAL TOLERANCE		DRAW: Martin	PART NO.: 0510B0BA56B
D	E070269A	Lio	09/18/2007	X. ±0.30	X° ± 2.00°	CHECKED:	TITLE: MINI PCI ASSEMBLY
C	E070065A	Martin	03/05/2007	.X ±0.20	.X° ± 1.00°		DRAWING NO. 0510B0BA56B
B	E060155A	WES	09/06/2006	.XX ±0.10	.XX° ± 0.50°	APPROVE: David	
REV.	ECO NO.	DESCRIPTION	DATE	UNITS: mm	SHEET: 1 / 2		
MATERIAL:		FINISH:	DATE: 10/13/2005	REV. A	 <b>CONCRAFT</b> DRAGONSTATE TECHNOLOGY CO., LTD		
A	B	C	D	E			

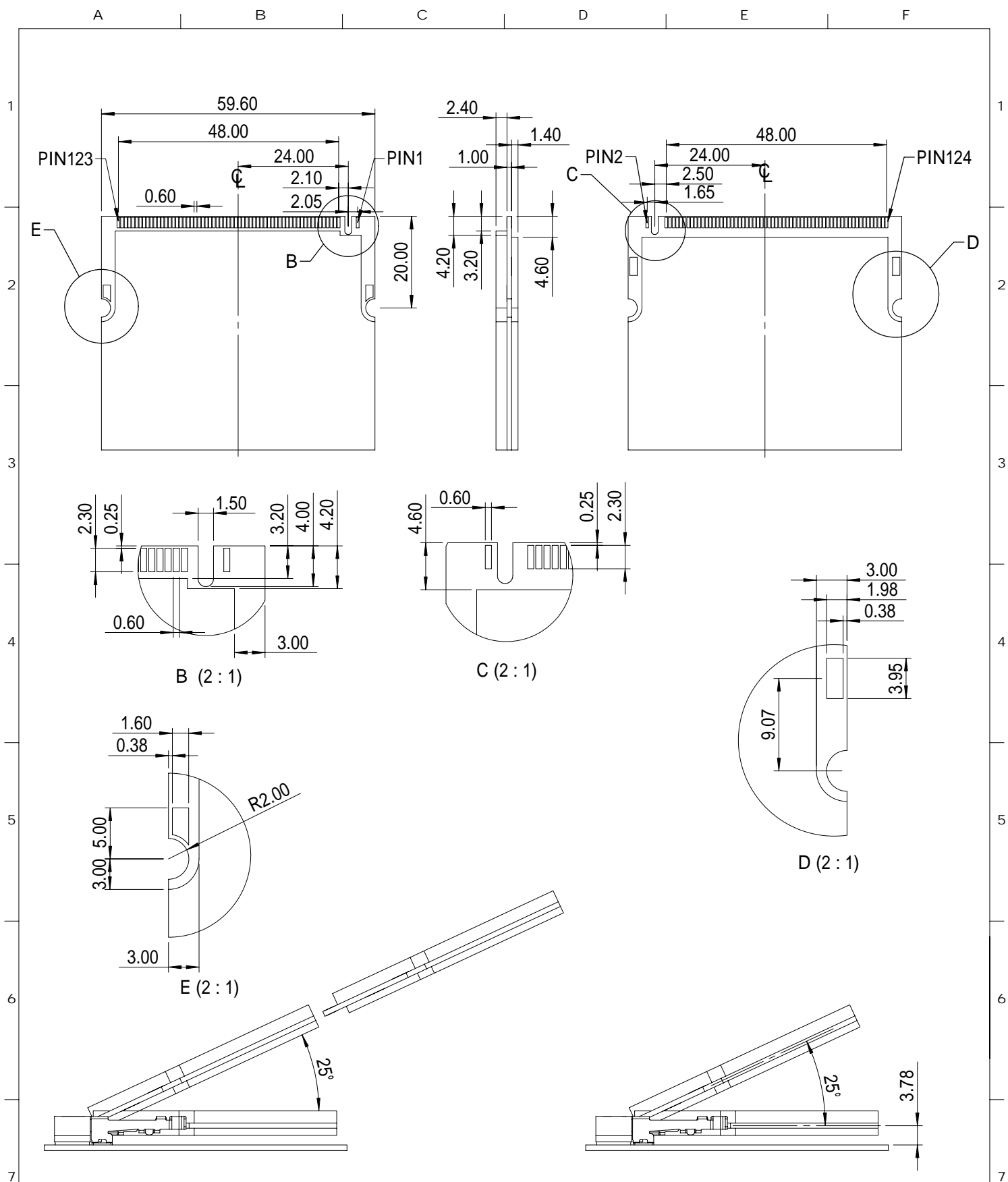

				GENERAL TOLERANCE		DRAW:	PART NO:
				X. ±0.30	X.° ± 2.00°	Martin	0510B0BA56B
D	E070269A	Lio	09/18/2007	.X ±0.20	.X° ± 1.00°	CHECKED:	TITLE:
C	E070065A	Martin	03/05/2007	.XX ±0.10	.XX° ± 0.50°		MINI PCI ASSEMBLY
B	E060155A	WES	09/06/2006	.XXX ±0.05		APPROVE:	DRAWING NO:
				UNITS: mm	SHEET: 2/2	David	0510B0BA56B
REV.	ECO NO.	DESCRIPTION	DATE	 <b>CONCRAFT</b> DRAGONSTATE TECHNOLOGY CO., LTD			
MATERIAL:	FINISH:	DATE:	REV. A				
A	B	C	10/13/2005				