

# BMA425

## Digital, triaxial acceleration sensor

Bosch Sensortec



**BOSCH**

Invented for life

### Data Sheet BMA425

Part number(s) 0 273 016 004

Document revision 1.0

Release date 26 March 2018

Document number BST-BMA425-DS000-00

Notes Specifications are preliminary and subject to change without notice. Product photos and pictures are for illustration purposes only and may differ from the real product's appearance.



## BMA425

12 bit, digital, triaxial acceleration sensor with intelligent on-chip motion-triggered interrupt features optimized for wearable applications.

### Key features

- Small package size LGA package (12 pins), footprint 2mm x 2mm, height 0.95 mm
- Digital interface SPI (4-wire, 3-wire), I<sup>2</sup>C, 2 interrupt pins  
V<sub>DDIO</sub> voltage range: 1.2V to 3.6V
- Programmable functionality Acceleration ranges  $\pm 2g/\pm 4g/\pm 8g/\pm 16g$   
Low-pass filter bandwidths 684Hz - <8Hz  
up to a max. output data read out of 1.6 kHz  
Integrated FIFO on sensor with 1 kb  
Step Counter optimized for wearable devices  
Activity Recognition: Running, Walking, Still  
Tilt-On-Wrist detection  
Tap/Double tap interrupt  
Any-/No-Motion interrupt
- Ultra-low power Low current consumption of data acquisition and all integrated features
- (Secondary) Auxiliary Interface Hub for ext. Magnetometer and data synchronization
- RoHS compliant, halogen-free

### Typical applications

- Plug 'n' Play Step-Counter solution with watermark functionality
- Fitness applications / Activity Tracking
- Power management for wearable applications
- Display on/off and profile switching
- User interface without hardware buttons
- E-compass tilt compensation and data synchronization

## Table of contents

<b>1. SPECIFICATION</b> .....	<b>7</b>
<b>2. ABSOLUTE MAXIMUM RATINGS</b> .....	<b>10</b>
<b>3. QUICK START GUIDE</b> .....	<b>11</b>
Note about using the BMA425: .....	11
First application setup examples algorithms: .....	11
<b>4. FUNCTIONAL DESCRIPTION</b> .....	<b>15</b>
4.1. SUPPLY VOLTAGE AND POWER MANAGEMENT .....	16
4.2. DEVICE INITIALIZATION.....	17
4.3. POWER MODES.....	18
4.4. SENSOR DATA .....	20
Acceleration Data .....	20
Filter Settings .....	20
Accelerometer data processing for low power mode.....	21
Data Ready Interrupt .....	21
Temperature Sensor .....	21
Sensor Time .....	22
Configuration Changes .....	22
4.5. FIFO.....	24
Frames .....	24
Conditions and Details.....	27
FIFO data synchronization.....	29
FIFO synchronization with external interrupts .....	30
FIFO Interrupts .....	30
FIFO Reset.....	30
4.6. INTERRUPT FEATURES.....	31
Global Configuration .....	31
Step Detector / Step Counter .....	33
Walking activity recognition.....	36
Tilt on Wrist.....	37
Double tap / Tap detection .....	39
Any Motion / No motion detection .....	40
4.7. GENERAL INTERRUPT PIN CONFIGURATION .....	42
Electrical Interrupt Pin Behavior.....	42
Interrupt Pin Mapping .....	42
4.8. AUXILIARY SENSOR INTERFACE.....	43
Structure and Concept.....	43
Interface Configuration .....	43
Setup mode (AUX_IF_CONF.aux_manual_en =0b1) .....	44
Data mode (AUX_IF_CONF.aux_manual_en=0) .....	47
Delay (Time Offset) .....	47

4.9.	SENSOR SELF-TEST .....	48
4.10.	OFFSET COMPENSATION .....	49
	Manual Offset Compensation .....	49
	Inline Calibration.....	49
4.11.	NON-VOLATILE MEMORY .....	50
4.12.	SOFT-RESET.....	50
<b>5.</b>	<b>REGISTER DESCRIPTION .....</b>	<b>51</b>
5.1.	GENERAL REMARKS .....	51
5.2.	REGISTER MAP .....	51
	Register (0x00) CHIP_ID .....	61
	Register (0x02) ERR_REG .....	61
	Register (0x03) STATUS.....	62
	Register (0x0A) DATA_0.....	62
	Register (0x0B) DATA_1.....	63
	Register (0x0C) DATA_2.....	63
	Register (0x0D) DATA_3.....	64
	Register (0x0E) DATA_4.....	64
	Register (0x0F) DATA_5.....	65
	Register (0x10) DATA_6 .....	65
	Register (0x11) DATA_7 .....	66
	Register (0x12) DATA_8 .....	66
	Register (0x13) DATA_9 .....	67
	Register (0x14) DATA_10 .....	67
	Register (0x15) DATA_11 .....	68
	Register (0x16) DATA_12 .....	68
	Register (0x17) DATA_13 .....	69
	Register (0x18) SENSORTIME_0.....	69
	Register (0x19) SENSORTIME_1.....	70
	Register (0x1A) SENSORTIME_2 .....	70
	Register (0x1B) EVENT.....	71
	Register (0x1C) INT_STATUS_0 .....	71
	Register (0x1D) INT_STATUS_1 .....	72
	Register (0x1E) STEP_COUNTER_0 .....	72
	Register (0x1F) STEP_COUNTER_1 .....	73
	Register (0x20) STEP_COUNTER_2 .....	73
	Register (0x21) STEP_COUNTER_3 .....	74
	Register (0x22) TEMPERATURE.....	74
	Register (0x24) FIFO_LENGTH_0.....	75
	Register (0x25) FIFO_LENGTH_1.....	75
	Register (0x26) FIFO_DATA .....	76
	Register (0x27) ACTIVITY_TYPE .....	76
	Register (0x2A) INTERNAL_STATUS.....	77
	Register (0x40) ACC_CONF.....	78

Register (0x41) ACC_RANGE .....	79
Register (0x44) AUX_CONF .....	80
Register (0x45) FIFO_DOWNS .....	81
Register (0x46) FIFO_WTM_0.....	81
Register (0x47) FIFO_WTM_1.....	82
Register (0x48) FIFO_CONFIG_0 .....	82
Register (0x49) FIFO_CONFIG_1 .....	83
Register (0x4B) AUX_DEV_ID.....	84
Register (0x4C) AUX_IF_CONF .....	84
Register (0x4D) AUX_RD_ADDR .....	85
Register (0x4E) AUX_WR_ADDR.....	85
Register (0x4F) AUX_WR_DATA .....	86
Register (0x53) INT1_IO_CTRL .....	86
Register (0x54) INT2_IO_CTRL .....	87
Register (0x55) INT_LATCH.....	88
Register (0x56) INT1_MAP.....	89
Register (0x57) INT2_MAP.....	89
Register (0x58) INT_MAP_DATA.....	90
Register (0x59) INIT_CTRL .....	90
Register (0x5E) FEATURES_IN.....	91
Register (0x5F) INTERNAL_ERROR.....	95
Register (0x6A) NVM_CONF.....	95
Register (0x6B) IF_CONF .....	96
Register (0x6D) ACC_SELF_TEST .....	96
Register (0x70) NV_CONF .....	97
Register (0x71) OFFSET_0 .....	98
Register (0x72) OFFSET_1 .....	98
Register (0x73) OFFSET_2 .....	99
Register (0x7C) PWR_CONF .....	99
Register (0x7D) PWR_CTRL .....	100
Register (0x7E) CMD.....	101
<b>6. DIGITAL INTERFACES .....</b>	<b>102</b>
6.1. INTERFACES .....	102
6.2. PRIMARY INTERFACE .....	103
6.3. PRIMARY INTERFACE I2C/SPI PROTOCOL SELECTION .....	104
6.4. SPI INTERFACE AND PROTOCOL .....	104
6.5. PRIMARY I2C INTERFACE.....	109
6.6. SPI AND I <sup>2</sup> C ACCESS RESTRICTIONS .....	113
6.7. AUXILIARY INTERFACE .....	113
<b>7. PIN-OUT AND CONNECTION DIAGRAMS .....</b>	<b>114</b>
7.1. PIN-OUT .....	114
7.2. CONNECTION DIAGRAMS WITHOUT AUXILIARY INTERFACE.....	115

SPI .....	115
I2C.....	116
7.3. CONNECTION DIAGRAMS WITH AUXILIARY INTERFACE.....	116
SPI .....	116
I2C.....	117
<b>8. PACKAGE.....</b>	<b>118</b>
8.1. PACKAGE OUTLINE DIMENSIONS .....	118
8.2. SENSING AXIS ORIENTATION.....	119
8.3. LANDING PATTERN RECOMMENDATION.....	121
8.4. MARKING.....	122
Mass production .....	122
Engineering samples .....	122
8.5. SOLDERING GUIDELINES .....	123
8.6. HANDLING INSTRUCTIONS .....	124
8.7. TAPE AND REEL SPECIFICATION .....	125
8.8. ENVIRONMENTAL SAFETY.....	126
Halogen content .....	126
Internal package structure .....	126
<b>9. LEGAL DISCLAIMER.....</b>	<b>127</b>
<b>9.1. ENGINEERING SAMPLES.....</b>	<b>127</b>
<b>9.2. PRODUCT USE .....</b>	<b>127</b>
<b>9.3. APPLICATION EXAMPLES AND HINTS.....</b>	<b>127</b>
<b>10. DOCUMENT HISTORY AND MODIFICATION.....</b>	<b>128</b>

# 1. Specification

Unless stated otherwise, the given values are over lifetime, operating temperature and voltage ranges. Minimum/maximum values are  $\pm 3\sigma$ .

## Parameter Specification

OPERATING CONDITIONS						
Parameter	Symbol	Condition	Min	Typ	Max	Units
Acceleration Range	$g_{FS2g}$	Selectable via serial digital interface		$\pm 2$		g
	$g_{FS4g}$			$\pm 4$		g
	$g_{FS8g}$			$\pm 8$		g
	$g_{FS16g}$			$\pm 16$		g
Supply Voltage Internal Domains	$V_{DD}$		1.62	1.8	3.6	V
Supply Voltage I/O Domain	$V_{DDIO}$		1.2	1.8	3.6	V
Voltage Input Low Level	$V_{IL}$	SPI & I <sup>2</sup> C			$0.3V_{DDIO}$	-
Voltage Input High Level	$V_{IH}$	SPI & I <sup>2</sup> C	$0.7V_{DDIO}$			-
Voltage Output Low Level	$V_{OL}$	$V_{DDIO} \geq 1.62V$ , $I_{OL} \leq 2mA$ , SPI			$0.2V_{DDIO}$	-
		$V_{DDIO} < 1.62V$ , $I_{OL} \leq 1.5mA$ , SPI			$0.2V_{DDIO}$	-
Voltage Output High Level	$V_{OH}$	$V_{DDIO} \geq 1.62V$ , $I_{OH} \leq 2mA$ , SPI	$0.8V_{DDIO}$			-
		$V_{DDIO} \leq 1.62V$ , $I_{OH} \leq 1.5mA$ , SPI	$0.8V_{DDIO}$			-
Total Supply Current in Performance mode	$I_{DD}$	Nominal $V_{DD}$ and $V_{DDIO}$ , 25°C, $g_{FS4g}$		150		$\mu A$
Total Supply Current in Suspend Mode	$I_{DDsum}$	Nominal $V_{DD}$ and $V_{DDIO}$ , 25°C		3.5		$\mu A$
Total Supply Current in Low-power Mode	$I_{DDlp1}$	Nominal $V_{DD}$ and $V_{DDIO}$ , 25°C 50 Hz ODR		14		$\mu A$
Power-Up Time	$ts_{up}$				1	ms
Non-volatile memory (NVM) write-cycles	$n_{NVM}$				15	cycles

Operating Temperature	$T_A$		-40		+85	°C
<b>OUTPUT SIGNAL</b>						
Parameter	Symbol	Condition	Min	Typ	Max	Units
Sensitivity	$S_{2g}$	$g_{FS2g}, T_A=25^\circ C$		1024		LSB/g
	$S_{4g}$	$g_{FS4g}, T_A=25^\circ C$		512		LSB/g
	$S_{8g}$	$g_{FS8g}, T_A=25^\circ C$		256		LSB/g
	$S_{16g}$	$g_{FS16g}, T_A=25^\circ C$		128		LSB/g
Sensitivity Temperature Drift	TCS			0.02		%/K
Zero-g Offset	Off	Nominal $V_{DD}$ and $V_{DDIO}, 25^\circ C, g_{FS4g}$		120		mg
Zero-g Offset Temperature Drift	TCO			1		mg/K
Output Data Rate	$ODR_{PERF}$	Performance mode	12.5		1600	Hz
Output data rate and BW in Performance mode	$ODR_{12.5}$	3dB cutoff frequency of the accelerometer according to ODR with normal filter mode		5.06		Hz
	$ODR_{25}$			10.12		Hz
	$ODR_{50}$			20.25		Hz
	$ODR_{100}$			40.5		Hz
	$ODR_{200}$			80		Hz
	$ODR_{400}$			162 (155 for Z axis)		Hz
	$ODR_{800}$			324 (262 for Z axis)		Hz
	$ODR_{1600}$			684 (353 for Z axis)		Hz
Output Data Rate	$ODR_{LPM}$	Low-power mode	0.78		400	Hz
Nonlinearity	NL	Nominal $V_{DD}$ and $V_{DDIO}, 25^\circ C, g_{FS4g}$		0.5		%FS
Output Noise Density	$n_{dens}$	Nominal $V_{DD}$ and $V_{DDIO}, 25^\circ C, g_{FS4g}$		220		$\mu g/\sqrt{Hz}$



**MECHANICAL CHARACTERISTICS**

<b>Parameter</b>	<b>Symbol</b>	<b>Condition</b>	<b>Min</b>	<b>Typ</b>	<b>Max</b>	<b>Units</b>
Cross Axis Sensitivity	S	relative contribution between any two of the three axes		2		%
Alignment Error	E <sub>A</sub>	relative to package outline		0.5		°

## 2. Absolute maximum ratings

### Absolute maximum ratings

Parameter	Condition	Min	Max	Units
Voltage at Supply Pin	V <sub>DD</sub> Pin	-0.3	4	V
	V <sub>DDIO</sub> Pin	-0.3	4	V
Voltage at any Logic Pin	Non-Supply Pin	-0.3	V <sub>DDIO</sub> +0.3, <4	V
Passive Storage Temp. Range	≤ 65% rel. H.	-50	+150	°C
None-volatile memory (NVM) Data Retention	T = 85°C, after 15 cycles	10		y
Mechanical Shock	Duration ≤ 200μs		10,000	g
	Duration ≤ 1.0ms		2,000	g
	Free fall onto hard surfaces		1.8	m
ESD, at any pin	HBM		2	kV
	CDM		500	V
	MM		200	V

**Note:**

Stress above these limits may cause damage to the device. Exceeding the specified electrical limits may affect the device reliability or cause malfunction.

### 3. Quick Start Guide

The purpose of this chapter is to help developers who want to start working with the BMA425 by giving you some very basic hands-on application examples to get started.

#### Note about using the BMA425:

The communication between application processor and BMA425 will happen either over i2c or spi interface. For more information about the interfaces, read the related chapter 6.

- Before starting the test, the device has to be properly connected to the master (AP) and powered up. For more information about it, read the related chapter 7. Pin-out and Connection Diagrams.

#### First application setup examples algorithms:

After correct power up by setting the correct voltage to the appropriate external pins, the BMA425 enters automatically into the Power On Reset (POR) sequence. In order to properly make use of the BMA425, certain steps from host processor side are needed. The most typical operations will be explained in the following application examples in form of flow-diagrams.

#### Example 1: Testing communication with the BMA425 and initializing feature engine

- reading chip id (checking correct communication)

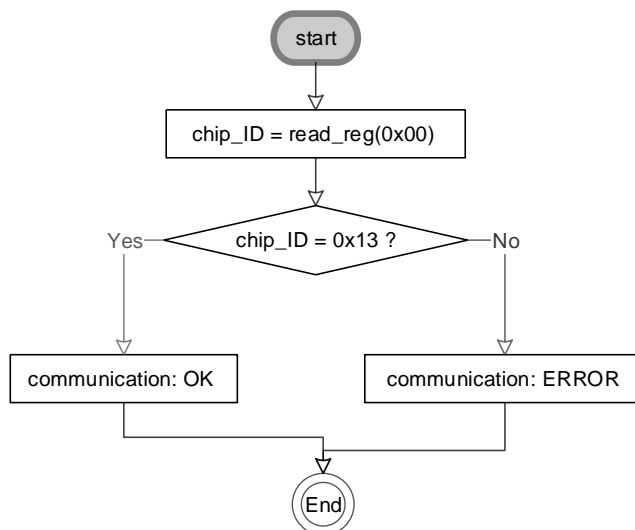

- performing initialization sequence (interrupt feature engine)

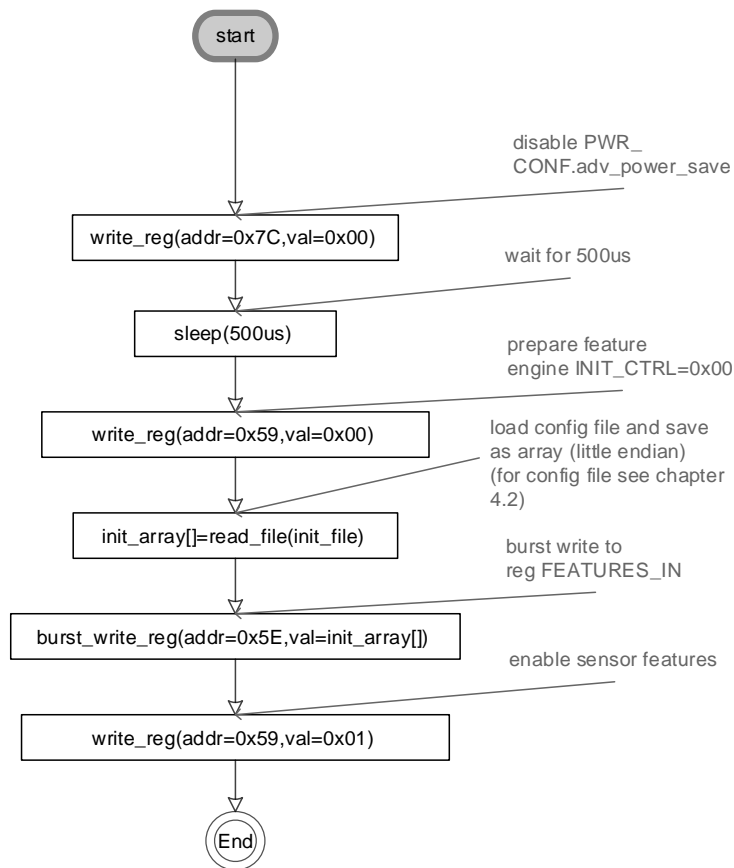

c. -checking the correct status of the interrupt feature engine

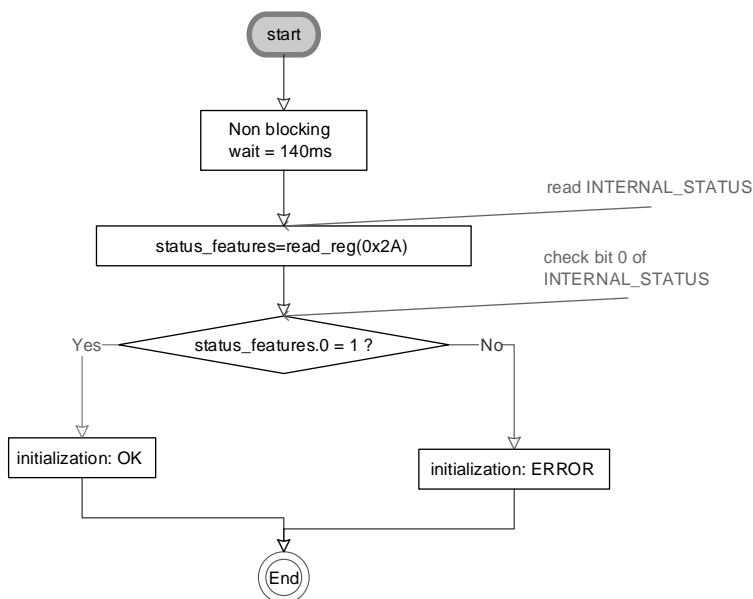



**Example 2: Reading acceleration data from BMA425 (example: low power mode)**

-setting data processing parameters (power, bandwidth, range) and reading sensor data

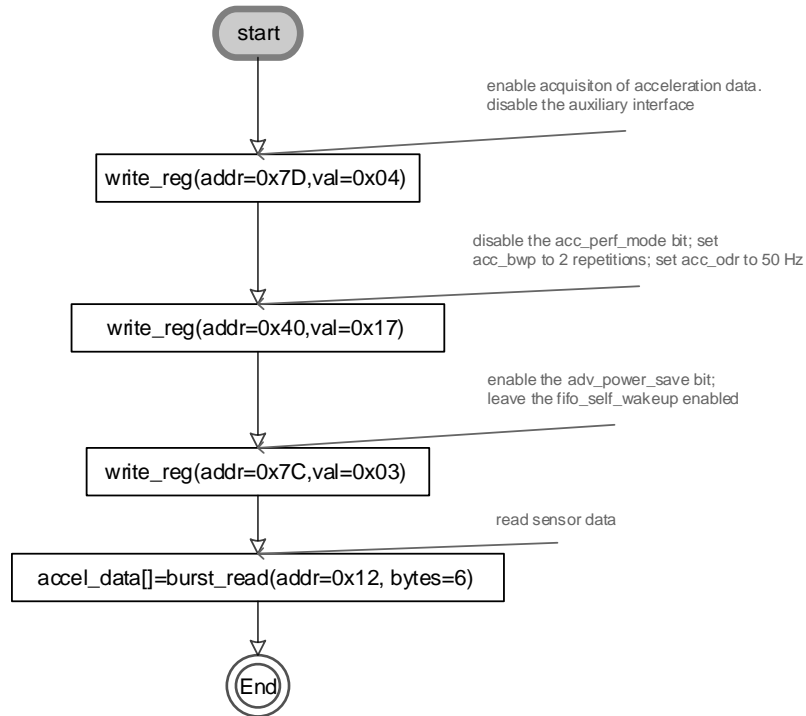

**Further steps:**

The BMA425 has many more capabilities that are described in this document and include FIFO, power saving modes, synchronization capabilities with host processor, data synchronization and integration with third party sensors, many interrupts generation and more features like step counter, etc.



## 4. Functional Description

### Block Diagram

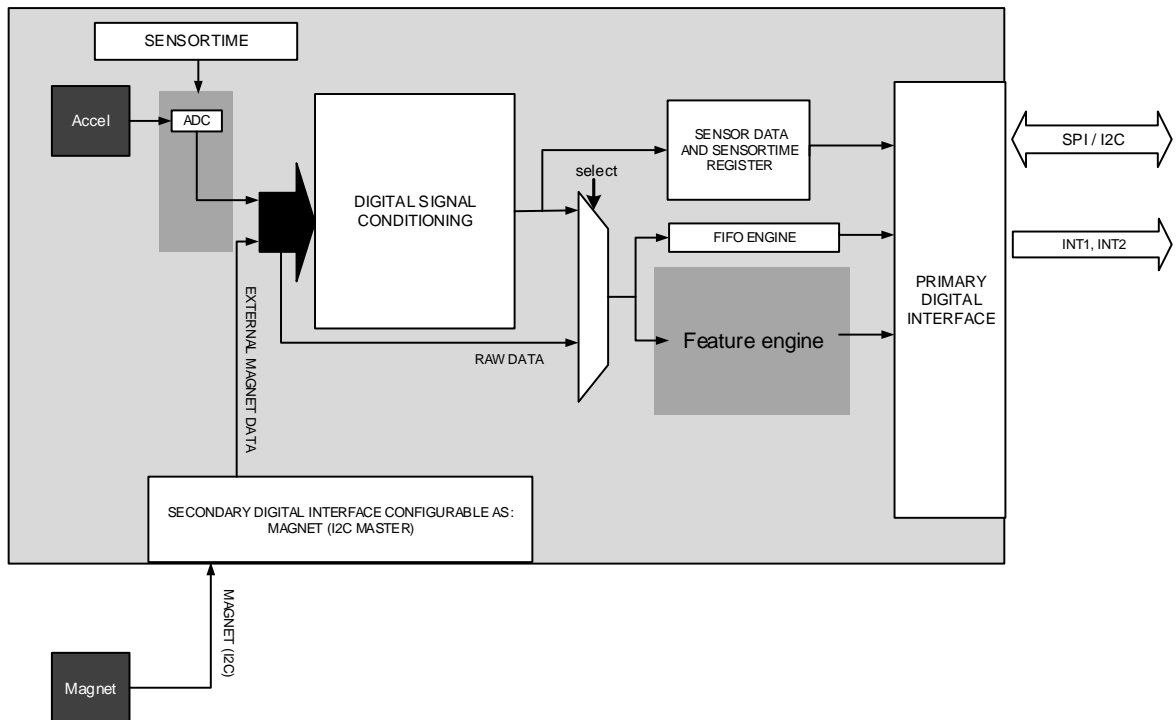

#### 4.1. Supply Voltage and Power Management

BMA425 has two distinct power supply pins:

- VDD is the main power supply.
- VDDIO is a separate power supply pin used for supplying power for the interface including the auxiliary interface.

There are no limitations with respect to the voltage level applied to the VDD and VDDIO pins, as long as it lies within the respective operating range. Furthermore, the device can be completely switched off (VDD= 0V) while keeping the VDDIO supply within operating range or vice versa. However if the VDDIO supply is switched off, all interface pins (CSB, SDX, SCX) must be kept close to GNDIO potential. The device is reset when the supply voltage applied to at least one supply pin VDD or VDDIO falls below the specified minimum values. No constraints exist for the minimum slew-rate of the voltage applied to the VDD and VDDIO pins.



## 4.2. Device Initialization

After power up sequence the accelerometer is in suspend mode, device must be initialized through the following procedure. Initialization has to be performed as well after every POR or soft reset.

- Disable advanced power save mode: [PWR\\_CONF.adv\\_power\\_save](#) =0b0
- Wait for 450 us. The register [SENSORTIME\\_0](#) increments every 39.25 µsec and may be used for accurate timing.
- Write [INIT\\_CTRL.init\\_ctrl](#)=0x00
- Load configuration file
  - Burst write initialization data to Register [FEATURES\\_IN](#). The configuration file is included in the driver available on the Bosch Sensortec website ([www.bosch-sensortec.com](http://www.bosch-sensortec.com)) or from your regional support team. Optionally the configuration file can be written to the Register [FEATURES\\_IN](#) in several consecutive burst write access. Every burst write must contain an even number of bytes.
  - Optionally:  
Burst read configuration file from Register [FEATURES\\_IN](#) and check correctness
- Enable sensor features– write 0x01 into register [INIT\\_CTRL.init\\_ctrl](#). This operation must not be performed more than once after POR or softreset.
- Wait until Register [INTERNAL\\_STATUS.message](#) contains the value 0b1. This will happen after at most 140-150 msec.

After initialization sequence has been completed, the device is in configuration mode (power mode). Now it is possible to switch to the required power mode and all features are ready to use as described in chapter 4.

### 4.3. Power Modes

The power state of the BMA425 is controlled through the registers [PWR\\_CONF](#) and [PWR\\_CTRL](#). The Register [PWR\\_CTRL](#) enables and disables the accelerometer and the auxiliary sensor. The Register [PWR\\_CONF](#) controls which power state the sensors enter if they are enabled or disabled in the Register [PWR\\_CTRL](#). The power state impacts the behavior of the sensor with respect to start-up time, available functions, etc. but not the sensor data quality. The sensor data quality is controlled in the Registers [ACC\\_CONF](#).

In all global power configurations both register contents and FIFO contents are retained.

**Low Power Mode:** This power configuration aggressively reduces power of the device as much as possible. The low power mode configuration is activated through enabling [PWR\\_CONF.adv\\_power\\_save=0b1](#) and disabling [ACC\\_CONF.acc\\_perf\\_mode=0b0](#). In this configuration these externally user visible features may not be available:

- Register writes need an inter-write-delay of at least **1000 us**.
- The sensors log data into the FIFO in performance and low power mode. When the FIFO watermark interrupt is active, the FIFO is accessible for reading in low power mode until a burst read operation on Register [FIFO\\_DATA](#) completes when [PWR\\_CONF.fifo\\_self\\_wakeup=0b1](#). When [PWR\\_CONF.fifo\\_self\\_wakeup=0b0](#), the user needs to disable advanced power save mode ([PWR\\_CONF.adv\\_power\\_save=0b0](#)) before reading the FIFO and wait for 250  $\mu$ s.
- To read out FIFO data w/o a FIFO watermark interrupt, the advanced power save configuration needs to be disabled ([PWR\\_CONF.adv\\_power\\_save=0b0](#))

The table below shows a few examples with the optimal power configurations

Usecase	<a href="#">ACC_CONF.acc_perf_mod</a>	<a href="#">PWR_CONF.adv_power_sa</a>	<a href="#">PWR_CTRL.acc_en</a>	Power consumption
Configuration mode	x	0	x	tbd
Suspend (lowest power mode)	x	1	0	suspend power
Performance mode accel	1	x	1	accel power
Low power mode	0	1	1	Depends on <a href="#">ACC_CONF</a>

The [PWR\\_CTRL](#) register is used to enable and disable sensors. Per default, all sensors are disabled. Acceleration sensor must be enabled by setting [PWR\\_CTRL.acc\\_en=0b1](#).



The auxiliary sensor functionality is supported only when the auxiliary interface is connected for the auxiliary sensor operation. If the auxiliary interface is not used for auxiliary sensor operation, then the auxiliary sensor interface must remain disabled by setting [PWR\\_CTRL.aux\\_en=0b0](#) (default).

To change the power mode of the auxiliary sensor, both the power mode of the auxiliary interface and the auxiliary sensor part needs to be changed, e.g. to set the auxiliary sensor to suspend mode:

- Set the auxiliary sensor interface to suspend in Register [PWR\\_CTRL.aux\\_en=0b0](#). Changing the auxiliary sensor interface power mode to suspend does not imply any mode change in the auxiliary sensor.
- The auxiliary sensor part itself must be put into suspend mode by writing the respective configuration bits of the auxiliary sensor part. The power mode of the auxiliary sensor part is controlled by setting the BMA425 auxiliary sensor interface into manual mode by [AUX\\_IF\\_CONF.aux\\_manual\\_en=0b1](#) and then communicating with the auxiliary sensor part through the BMA425 registers [AUX\\_RD\\_ADDR](#), [AUX\\_WR\\_ADDR](#), and [AUX\\_WR\\_DATA](#). For details see Chapter 4.8.

#### 4.4. Sensor Data

##### Acceleration Data

The width of acceleration data is 12 bits given in two's complement representation in the registers [DATA 8](#) to [DATA 13](#). The 12 bits for each axis are split into an MSB upper part and an LSB lower part. Reading the acceleration data registers shall always start with the LSB part. In order to ensure the integrity of the acceleration data, the content of an MSB register is locked by reading the corresponding LSB register (shadowing procedure).

##### Filter Settings

The accelerometer digital filter can be configured through the Register [ACC\\_CONF](#).

##### Note:

Illegal settings in configuration registers will result in an error code in Register [ERR\\_REG](#). The content of the data register is undefined, and if the FIFO is used, it may contain no value.

##### Accelerometer data processing for performance mode

Performance mode is enabled with [ACC\\_CONF.acc\\_perf\\_mode](#)=0b1. In this power mode, the accelerometer data is sampled at equidistant points in the time, defined by the accelerometer output data rate parameter [ACC\\_CONF.acc\\_odr](#). The output data rate can be configured in one of eight different valid ODR configurations going from 12.5 Hz up to 1600Hz.

The filter bandwidth shows a 3db cutoff frequency shown in the following table:

Table 12: 3dB cutoff frequency of the accelerometer according to ODR with normal filter mode

Accelerometer ODR [Hz]	12.5	25	50	100	200	400	800	1600
3dB Cutoff frequency [Hz]	5.06	10.12	20.25	40.5	80	162 (155 for Z axis)	324 (262 for Z axis)	684 (353 for Z axis)

The noise is also depending on the filter settings and ODR, see table below.

Table 13: Accelerometer noise in mg according to ODR with normal filter mode (range +/- 4g)  
(based on device measurement)

ODR in Hz	25	50	100	200	400	800	1600
RMS-Noise (typ.) [mg]	0.5	0.7	0.9	1.3	1.7	TBD	TBD

### Accelerometer data processing for low power mode

Low power mode can be enabled by [PWR\\_CONF.adv\\_power\\_save=0b1](#) and [ACC\\_CONF.acc\\_perf\\_mode=0b0](#). In this power mode, the accelerometer regularly changes between a suspend power mode phase where no measurement is performed and a performance power mode phase, where data is acquired. The period of the duty cycle for changing between suspend and performance mode will be determined by the output data rate ([ACC\\_CONF.acc\\_odr](#)). The output data rate can be configured in one of 10 different valid ODR configurations going from 0.78Hz up to 400Hz. The samples acquired during the normal mode phase will be averaged and the result will be the output data. The number of averaged samples can be determined by the parameter [ACC\\_CONF.acc\\_bwp](#) through the following formula:

$$\begin{aligned} \text{averaged samples} &= 2^{(\text{Val}(\text{acc\_bwp}))} \\ \text{skipped samples} &= (1600/\text{ODR}) - \text{averaged samples} \end{aligned}$$

A higher number of averaged samples will result in a lower noise level of the signal, but since the performance power mode phase is increased, the power consumption will also rise.

### Data Ready Interrupt

This interrupt fires whenever a new data sample set from accelerometer, and auxiliary sensor is complete. This allows a low latency data readout. In non-latched mode, the interrupt and the flag in Register [INT\\_STATUS\\_1](#) are cleared automatically after 1/(3200Hz). If this automatic clearance is unwanted, latched-mode can be used (see chapter 4.7).

In order to enable/use the data ready interrupt map it on the desired interrupt pin via [INT\\_MAP\\_DATA](#).

### Temperature Sensor

The temperature sensor has 8 bits. The temperature value is defined in Register [TEMPERATURE](#) and updated every 1.28 s.

It is always on, when a sensor is active.

Value	Temperature
0x7F	150 °C
...	...
0x00	23 °C
...	...
0x81	-104 °C
0x80	Invalid

When there is no valid temperature information available (i.e. last measurement before the time defined above), the temperature indicates an invalid value: 0x80.

## Sensor Time

The BMA425 supports the concept of sensortime. Its core element is a free running counter with a width of 24 bits. It increments with a resolution of 39.0625 $\mu$ s. The user can access the current state of the counter by reading registers [SENSORTIME\\_0](#) to [SENSORTIME\\_2](#).

All sensor events e.g. updates of data registers are synchronous to this sensor time register as defined in the table below. With every update of the data register or the FIFO, a bit  $m$  in the registers [SENSORTIME\\_0](#) to [SENSORTIME\\_2](#) toggles where  $m$  depends on the output data rate for the data register and the output data rate and the FIFO downsampling rate for the FIFO. The table below shows which bit toggles for which update rate of data register and FIFO

Bit $m$ in sensor_time	23	22	21	20	19	18	17	16
Resolution [s]	327.68	163.84	81.92	40.96	20.48	10.24	5.12	2.56
Update rate [Hz]	0.0031	0.0061	0.012	0.024	0.049	0.10	0.20	0.39

Bit $m$ in sensor_time	15	14	13	12	11	10	9	8	7	6	5	4	3	2	1	0
Resolution [ms]	1280	640	320	160	80	40	20	10	5	2.5	1.250	0.625	0.3125	0.156	0.078	0.039
Update rate [Hz]	0.78	1.56	3.125	6.25	12.5	25	50	100	200	400	800	1600	3200			

The sensortime is synchronized with the data capturing in the data register and the FIFO. Between the data sampling and the data capturing there is a delay which depends on the settings in the Register [ACC\\_CONF](#). The sensortime supports multiple seconds of sample counting and a sub-microsecond resolution, see Register [SENSORTIME\\_0](#) for details.

Burst reads on the registers [SENSORTIME\\_0](#) to [SENSORTIME\\_2](#) deliver always consistent values, i.e. the value of the register does not change during the burst read.

## Configuration Changes

If accelerometer configuration settings in registers [ACC\\_CONF](#), [ACC\\_RANGE](#), or [AUX\\_CONF](#) are changed while the accelerometer ([PWR\\_CTRL.acc\\_en](#) = 0b1) or auxiliary sensor ([PWR\\_CTRL.aux\\_en](#) = 0b1) is enabled, the configuration changes are not immediately applied. The configuration changes become effective if a sampling event for the currently active ODR coincides with a sampling event for the newly requested ODR on the sensortime sampling grid. In the case where the currently active ODR equals the newly requested ODR, the configuration changes become effective at the next sampling event. See also following figure.

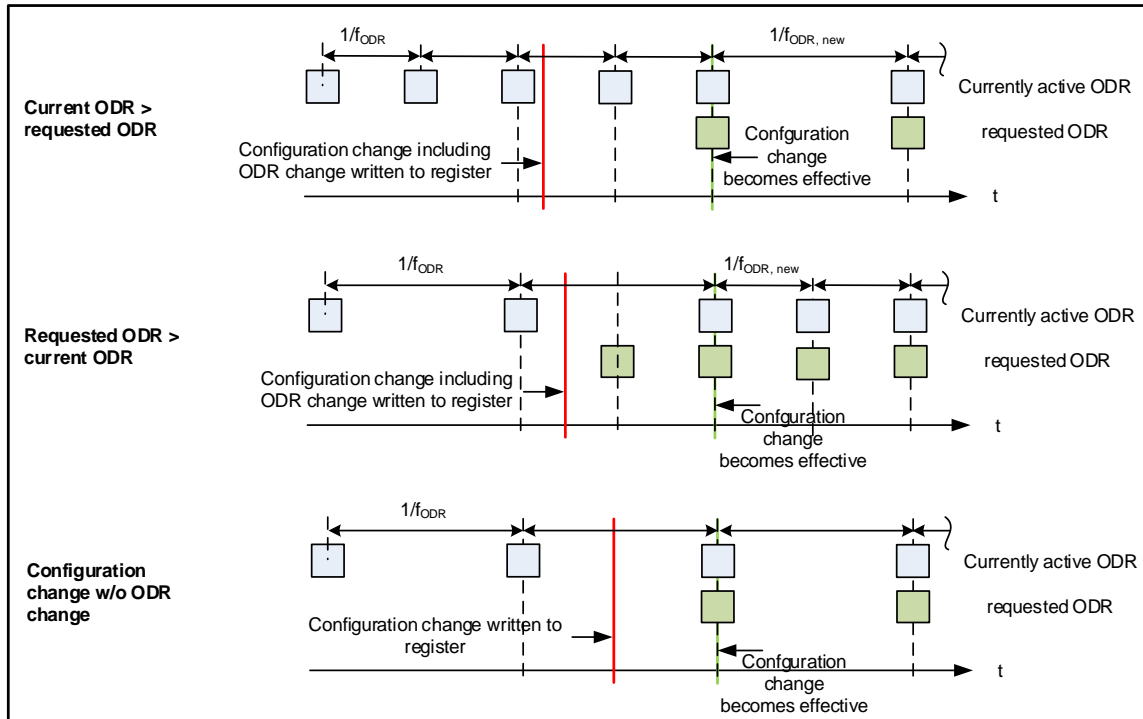



#### 4.5. FIFO

The device supports the following FIFO operating modes:

- Streaming mode: overwrites oldest data on FIFO full condition
- FIFO mode: discards newest data on FIFO full condition

The FIFO depth is 1024 byte and supports the following interrupts:

- FIFO full interrupt
- FIFO watermark interrupt

FIFO is enabled with [FIFO CONFIG 1.fifo acc en=0b1](#) (0b0= disabled). To enable the FIFO for the auxiliary interface (magnetometer) set [FIFO CONFIG 1.fifo aux en=0b1](#) (0b0=disabled).

#### Frames

The FIFO captures data in frames, which consist of a header and a payload. The FIFO can be configured to skip the header (headerless mode) in which case only payload is stored.

- In header mode (standard configuration) each regular frame consists of a one byte header describing properties of the frame, (which sensors are included in this frame) and the data itself. Beside the regular frames, there are control frames.
- In headerless mode the FIFO contains sampled data only.

#### Header mode

The header has a length of 8 bit and the following format:

Bit	7	6	5	4	3	2	1	0
Content	fh_mode<1:0>		fh_parm<3:0>			fh_ext<1:0>		

These *fh\_mode* and *fh\_parm* and *fh\_ext* fields are defined below

fh_mode<1:0>	Definition	fh_parm <3:0>	fh_ext<1:0>
0b10	Regular	Enabled sensors	Tag of INT2 and INT1
0b01	Control	Control opcode	
0b00 and 0b11	Reserved	Na	

f\_parm=0b0000 is invalid for regular mode, a header of 0x80 indicates an uninitialized frame.

In a regular frame, fh\_parm frame defines which sensors are included in the data part of the frame. The format is

Name	fh_parm<3:0>			
Bit	3	2	1	0
Content	Reserved	FIFO_aux_data	Reserved	FIFO_acc_data



When FIFO\_<sensor x>\_data is 0b1 (0b0) data for sensor x is included (not included) in the data part of the frame.

The fh\_ext<1:0> field are used for external tagging.

The data format for data frames is identical to the format defined for the [Register \(0x0A\) DATA 0](#) to [Register \(0x17\) DATA 13](#) register. Only frames which contain data of at least one sensor will be written into the FIFO. E.g. fh\_parm=0b0101 the data in the frame are shown below. If the read burst length is less than 8 byte, the number of auxiliary sensor data in the frame is reduced to the burst length.

DATA[X]	Acronym	
X=0	AUX_0	copy of register Val( <a href="#">AUX_RD_ADDR</a> ) in auxiliary sensor register map
X=1	AUX_1	copy of register Val( <a href="#">AUX_RD_ADDR</a> )+1 in auxiliary sensor register map
X=2	AUX_2	copy of register Val( <a href="#">AUX_RD_ADDR</a> )+2 in auxiliary sensor register map
X=3	AUX_3	copy of register Val( <a href="#">AUX_RD_ADDR</a> )+3 in auxiliary sensor register map
X=4	AUX_4	copy of register Val( <a href="#">AUX_RD_ADDR</a> )+4 in auxiliary sensor register map
X=5	AUX_5	copy of register Val( <a href="#">AUX_RD_ADDR</a> )+5 in auxiliary sensor register map
X=6	AUX_6	copy of register Val( <a href="#">AUX_RD_ADDR</a> )+6 in auxiliary sensor register map
X=7	AUX_7	copy of register Val( <a href="#">AUX_RD_ADDR</a> )+7 in auxiliary sensor register map
X=8	ACC_X<7:0> (LSB)	
X=9	ACC_X<15:8> (MSB)	
X=10	ACC_Y<7:0> (LSB)	
X=11	ACC_Y<15:8> (MSB)	
X=12	ACC_Z<7:0> (LSB)	
X=13	ACC_Z<15:8> (MSB)	

### Headerless mode

When the data rates of all enabled sensor elements are identical, the FIFO header may be disabled in [FIFO CONFIG 1.fifo header en](#).

The headerless mode supports only regular frames. To be able to distinguish frames from each other, all frames must have the same size. For this reason, any change in configuration that have an impact to frame size or order of data within a frame will cause an instant flush of FIFO, restarting capturing of data with the new settings.



If the auxiliary sensor interface is enabled, the number of auxiliary sensor bytes in a FIFO frame is always [AUX\\_IF\\_CONF.aux\\_rd\\_burst](#) bytes (see chapter 4.8). If the burst length is less than 8, BMA425 will pad the values read from the auxiliary sensor. E.g. if [AUX\\_IF\\_CONF.aux\\_rd\\_burst=0b01](#) (2 Bytes), a frame with auxiliary sensor and accelerometer data will look like

<b>DATA[X]</b>	<b>Acronym</b>	
X=0	AUX_0	copy of register Val( <a href="#">AUX_RD_ADDR.read_addr</a> ) in auxiliary sensor register map
X=1	AUX_1	copy of register Val( <a href="#">AUX_RD_ADDR.read_addr+1</a> ) in auxiliary sensor register map
X=2	Padding byte	Undefined value
X=3	Padding byte	Undefined value
X=4	Padding byte	Undefined value
X=5	Padding byte	Undefined value
X=6	Padding byte	Undefined value
X=7	Padding byte	Undefined value
X=8	ACC_X<7:0> (LSB)	
X=9	ACC_X<15:8> (MSB)	
X=10	ACC_Y<7:0> (LSB)	
X=11	ACC_Y<15:8> (MSB)	
X=12	ACC_Z<7:0> (LSB)	
X=13	ACC_Z<15:8> (MSB)	

## Conditions and Details

### Frame rates

The frame sampling rate of the FIFO is defined by the maximum output data rate of the sensors enabled for FIFO sampling. The FIFO sampling configuration is set in register [FIFO CONFIG 0](#) to [FIFO CONFIG 1](#). It is possible to select filtered or pre-filtered data as an input to the FIFO. If unfiltered data are selected in register [FIFO\\_DOWNS.acc\\_fifo\\_filt\\_data](#) for the accelerometer, the sample rate is 1600 Hz. The input data rate to the FIFO can be reduced by selecting a down-sampling factor  $2^k$  in register [FIFO\\_DOWNS.acc\\_fifo\\_downs](#), where  $k=[0,1..7]$ .

### FIFO Overflow

In the case of overflow the FIFO can either stop recording data or overwrite the oldest data. The behavior is controlled by Register [FIFO CONFIG 0.fifo\\_stop\\_on\\_full](#). When [FIFO CONFIG 0.fifo\\_stop\\_on\\_full](#) =0b0, the FIFO logic may delete the oldest frames. If header mode is enabled, the skip frame is prepended at the next FIFO readout, when the free FIFO space falls below the maximum size frame.

If [FIFO CONFIG 0.fifo\\_stop\\_on\\_full](#) =0b1, the newest frame may be discarded, if the free FIFO space falls below the maximum size frame. If header mode is enabled, a skip frame is prepended at the next FIFO readout (which is **not** the position where the frame(s) have been discarded).

During a FIFO read operation of the host, no data at the FIFO tail may be dropped. If the host reads the FIFO with a slower rate than it is filled, it may happen that the sensor needs to drop new data, even when [FIFO CONFIG 0.fifo\\_stop\\_on\\_full](#) =0b0. These events are recorded in the Register [ERR\\_REG.fifo\\_err](#).

### Control frames

Control frames are only supported in header mode. There are a number of control frames defined through the *fh\_parm* field. These are shown in below.

A skip frame indicates the number of skipped frames after a FIFO overrun occurred, a sensortime frame contains the sensortime when the last sampled frame stored in the FIFO is read, a FIFO input config frames indicates a change in sensor configuration which affects the sensor data.

The FIFO fill level is contained in registers [FIFO LENGTH 1.fifo\\_byte\\_counter 13 8](#) and [FIFO LENGTH 0.fifo\\_byte\\_counter 7 0](#) and includes the control frames, with the exception of the sensortime frame.

<b>fh_mode&lt;3:0&gt;</b>	<b>Definition</b>
0x0	Skip Frame
0x1	Sensortime Frame
0x2	Fifo_Input_Config Frame
0x3	Reserved
0x4	Sample Drop Frame
0x5 – 0x7	Reserved

**Skip Frame (fh\_parm=0x0):**

In the case of FIFO overflows, a skip\_frame is prepended to the FIFO content, when read out next time. The data for the frame consists of one byte and contains the number of skipped frames. When more than 0xFF frames have been skipped, 0xFF is returned. A skip frame is expected always as first frame in a FIFO read burst. A skip frame does not consume memory in the FIFO.

**Sensortime Frame (fh\_parm=0x1):**

The data for the sensortime frame consists content of the Register [SENSORTIME 0](#) to [SENSORTIME 2](#) when the last byte of the last sample frame was read. A sensortime frame is always expected as last frame in the FIFO. A sensortime frame is only sent if the FIFO becomes empty during the burst read. A sensortime frame does not consume memory in the FIFO. Sensortime frames are enabled (disabled) by setting [FIFO\\_CONFIG 0.fifo\\_time\\_en](#) to 0b1 (0b0).

**Fifo\_Input\_Config Frame (fh\_parm=0x2):**

Whenever the filter configuration of the FIFO input data sources changes, a FIFO input config frame is inserted into the FIFO, before the configuration change becomes active. E.g. when the bandwidth for the accelerometer filter is changed in Register [ACC\\_CONF](#), a FIFO input config frame is inserted before the first frame with accelerometer data with the new bandwidth configuration. The FIFO input config frame contains one byte of data with the format

Bit	7	6	5	4	3	2	1	0
Content	reserved		aux_ if_ch	aux_ conf_ch	reserved	reserved	acc_ range_ch	acc_ conf_ch

aux\_if\_ch: A write to Register [AUX\\_IF\\_CONF](#), [AUX\\_RD\\_ADDR](#), or [AUX\\_WR\\_ADDR](#) becomes active.

aux\_conf\_ch: A write to Register [AUX\\_CONF](#) becomes active.

acc\_range\_ch: A write to Register [ACC\\_RANGE](#) becomes active.

acc\_conf\_ch: A write to Register [ACC\\_CONF](#) or acc\_FIFO\_filt\_data or acc\_FIFO\_downsampling in Register [FIFO\\_DOWNS](#) becomes active.

**Sample Drop Frame**

A sample drop frame has always one byte payload, defined through

Bit	7	6	5	4	3	2	1	0
Content	reserved					aux_drop	reserved	acc_ drop

Sample drop frame will be inserted after a Fifo\_Input\_Config frame at the ODR tick at which the sample was dropped and only if no other sensor provides a valid sample at this ODR tick. If another sensor provides valid data, the data of this sensor is just not included and the appropriate header bit of the data frame is not set.

Sample drop frames will be inserted only for transition phases after configuration changes, not for samples dropped between sensor enable and first valid sample. For a detailed description of configuration changes see Section 4.4, Subsection “Configuration Changes”.

#### *FIFO Partial frame reads*

When a frame is only partially read through the Register [FIFO\\_DATA](#) it will be repeated completely with the next access both in headerless and in header mode. In headermode, this includes the header. In the case of a FIFO overflow between the first partial read and the second read attempt, the frame may be deleted.

#### *FIFO overreads*

When more data are read from the FIFO than it contains valid data, 0x8000 is returned in headerless mode. In header mode 0x80 indicates an invalid frame.

### **FIFO data synchronization**

All sensor data are sampled with respect to a common ODR time grid. Even if a different ODR is selected for the acceleration and the magnetic sensor the data remains synchronized:

If a frame contains a sample from a sensor element with ODR  $x$ , then it must contain also samples of all sensor elements with an ODR  $y \geq x$ . This applies for steady state operation. In transition phases, it is more important not to lose data, therefore exceptions are possible if the sensor elements with ODR  $y \geq x$  do not have data, e.g. due to a sensor configuration change.

FIFO Data Synchronization Scheme in the following figure illustrates the steady state and transient operating conditions.

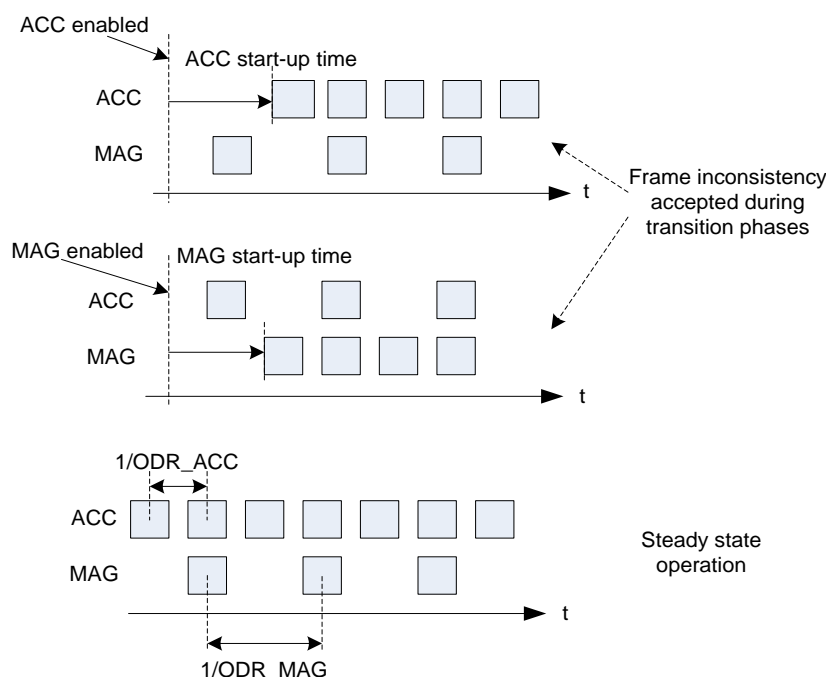

### FIFO synchronization with external interrupts

External interrupts may be synchronized into the FIFO data. For this operation mode the [FIFO CONFIG 1.fifo tag int1 en](#) and [FIFO CONFIG 1.fifo tag int2 en](#) need to be enabled, as well as [INT1 IO CTRL.input en](#) and [INT2 IO CTRL.input en](#). The `fh_ext` field in FIFO header will then be set according to the signal at the INT1/INT2 inputs.

### FIFO Interrupts

The FIFO supports two interrupts, a FIFO full interrupt and a watermark interrupt:

- The FIFO full interrupt is issued when the FIFO fill level is above the full threshold. The full threshold is reached just before the last two frames are stored in the FIFO.
- The FIFO watermark is issued when the FIFO fill level is equal or above a watermark defined in Register [FIFO\\_WTM\\_0](#) and [FIFO\\_WTM\\_1](#).

In order to enable/use the FIFO full or watermark interrupts map them on the desired interrupt pin via [INT\\_MAP\\_DATA](#).

Both interrupts are suppressed when a read operation on the Register [FIFO\\_DATA](#) is ongoing. Latched FIFO interrupts will only get cleared, if the status register gets read and the fill level is below the corresponding FIFO interrupt (full or watermark).

### FIFO Reset

The user can trigger a FIFO reset by writing the command `fifo_flash` (0xB0) in [CMD](#). Automatic resets are only performed in the following cases:

- A sensor is enabled or disabled in headerless mode
- A transition between headerless and headermode or vice versa has occurred.
- Size of auxiliary sensor data in a frame changed in header or headerless mode

## 4.6. Interrupt Features

### Global Configuration

The configuration of the interrupt feature engine is described in the Register [FEATURES\\_IN](#). In order to reconfigure the features, the user must perform a burst read of the whole content from the Register [FEATURES\\_IN](#), followed by a modification of the content, and finally a burst write of the modified content to the Register [FEATURES\\_IN](#). The content of the successive bytes read or written in burst mode correspond to the single bytes 0x00 to 0x3F described in [FEATURES\\_IN](#).

Make sure sensor is initialized properly before the feature configuration is performed (see description in chapter 4.2.)

The output of the interrupt features can be read out of the status registers listed below.

Interrupt feature status registers

Feature	Output status
Step Detector/Counter	<a href="#">INT STATUS 0.step counter out</a>
Activity Recognition	<a href="#">INT STATUS 0.activity type out</a>
Tilt on wrist	<a href="#">INT STATUS 0.wrist tilt out</a>
Double Tap / Tap	<a href="#">INT STATUS 0.wakeup out</a>
Any Motion / No Motion	<a href="#">INT STATUS 0.any no motion out</a>
Error Interrupt	<a href="#">INT STATUS 0.error int out</a>

Additionally, the Step counter numeric value is stored in the registers: [STEP COUNTER 0](#), [STEP COUNTER 1](#), [STEP COUNTER 2](#) and [STEP COUNTER 3](#).

The Error Interrupt signals that the sensor stopped after a fatal error. The Device reinitialization must be done.

The Features (algorithms) have as input data the acceleration samples, which are acquired at 50Hz.

#### Minimum Bandwidth Settings

If Performance mode is enabled ([ACC\\_CONF.acc\\_perf\\_mode](#) is 0b1, so continuous mode is used), then the features are functioning correctly, regardless to the ODR and the Bandwidth that the Host would set.

If Performance Mode is disabled ([ACC\\_CONF.acc\\_perf\\_mode](#) is 0b0) (device in low power mode), then the minimum ODR setting must comply with the following restrictions:

1. The ODR must be set to minimum 50 Hz for the most features except Double Tap/Tap
2. The ODR must be set to minimum 200 Hz for the use of Double Tap/ Tap feature

If the minimum requirements are not met, the corresponding flag from the register [INTERNAL STATUS](#) is set.

### Axes remapping for interrupt features

If the sensor orientation is different than described in chapter 8.2 the sensor axis must be remapped to use the integrated features.

Axes remapping register allows the host to freely map individual axis to the coordinate system of the used platform. Individual axis can be mapped to any other defined axis. The sign value of the axis can be also configured. For example x axis can be mapped to  $-x$  axis,  $+y$  axis,  $-y$  axis,  $+z$  axis or  $-z$  axis. Similarly other axis also have its own combination.

### **Note:**

The axis remapping does apply only to the data fetched into the Features. The [DATA 0](#) to [DATA 13](#) registers and FIFO are not affected and should be accordingly remapped on the driver level.

### Configuration settings:

1. [FEATURES\\_IN.general\\_settings.axes\\_remapping.map\\_x\\_axis](#) – describes which axis shall be mapped to x axis.
2. [FEATURES\\_IN.general\\_settings.axes\\_remapping.map\\_x\\_axis\\_sign](#) – describes whether the mapped axis shall be inverted or not to be inverted.
3. [FEATURES\\_IN.general\\_settings.axes\\_remapping.map\\_y\\_axis](#) – describes which axis shall be mapped to y axis.
4. [FEATURES\\_IN.general\\_settings.axes\\_remapping.map\\_y\\_axis\\_sign](#) – describes whether the mapped axis shall be inverted or not to be inverted.
5. [FEATURES\\_IN.general\\_settings.axes\\_remapping.map\\_z\\_axis](#) –describes which axis shall be mapped to z axis.
6. [FEATURES\\_IN.general\\_settings.axes\\_remapping.map\\_z\\_axis\\_sign](#) – describes whether the mapped axis shall be inverted or not to be inverted.



## Step Detector / Step Counter

The Step Counter algorithm is optimized on high accuracy, while Step Detector is optimized on low latency. Both are running in parallel, once enabled, but the Step Detector interrupt output is mutually exclusive with the Step Counter watermark interrupt. The Step Counter is optimized for wearable devices and wrist use case.

In addition the Step Counter implements the function required for step counting in Android 4.4 and higher as well: [https://source.android.com/devices/sensors/sensor-types.html#step\\_counter](https://source.android.com/devices/sensors/sensor-types.html#step_counter).

The Step Detector implements the function required for step counting in Android 4.4 and higher: [https://source.android.com/devices/sensors/sensor-types.html#step\\_detector](https://source.android.com/devices/sensors/sensor-types.html#step_detector).

### Step Counter:

Step Counter can be enabled in [FEATURES IN.step\\_counter.settings 26.en\\_counter](#).

The step counter accumulates the steps detected by the step detector interrupt, and makes available the 32 bit current step counter value in the following 4 registers, each holding 8bit: [STEP\\_COUNTER\\_0](#), [STEP\\_COUNTER\\_1](#), [STEP\\_COUNTER\\_2](#) and corresponding, [STEP\\_COUNTER\\_3](#). There are situations when the step counting value is different than the sum of steps detected by the step detector.

By enabling the [FEATURES IN.step\\_counter.settings 26.reset\\_counter](#) flag, the accumulated step number value is reset. Afterwards, the value of this flag is automatically reset and counting is restarted. The step counter watermark option can be useful if host needs to receive an interrupt every time a certain number of steps were counted. If [FEATURES IN.step\\_counter.settings 26.watermark\\_level](#) is set to 10 (holding an implicit factor of 20x), every 200 steps are counted an interrupt will be raised on [INT STATUS 0.step\\_counter\\_out](#). As the steps are buffered internally, the output may be triggered between 200-210 steps. The exact number of steps recorded is available in the registers [STEP\\_COUNTER\\_0](#), [STEP\\_COUNTER\\_1](#), [STEP\\_COUNTER\\_2](#) and [STEP\\_COUNTER\\_3](#). When the watermark level was reached, the corresponding interrupt bit is asserted, [INT STATUS 0.step\\_counter\\_out](#).

### Step Detector:

The Step Detector feature is optimized for low latency. If [FEATURES IN.step\\_counter.settings 26.en\\_detector](#) is set, an interrupt is triggered for every step detected. So, every time a new step is detected, it asserts the corresponding interrupt output [INT STATUS 0.step\\_counter\\_out](#).

### Step Counter Presets (phone/wrist use case):

The integrated step counter can be configured to work with either phone platform or wrist platform. The step counter parameters [FEATURE IN.step\\_counter.settings 1.param 1](#) to [FEATURE IN.step\\_counter.settings 25.param 25](#) must be configured from the host side to either of the configurations in the following table.

<b>Parameter Name</b>	<b>Phone Configuration</b>	<b>Wrist Configuration</b>
PARAM_1	306	301
PARAM_2	30950	31700
PARAM_3	132	315
PARAM_4	27804	31451
PARAM_5	7	4
PARAM_6	30052	31551
PARAM_7	32426	27853
PARAM_8	1375	1219
PARAM_9	2750	2437
PARAM_10	1375	1219
PARAM_11	-5994	-6420
PARAM_12	16879	17932
PARAM_13	1	1
PARAM_14	12	39
PARAM_15	12	25
PARAM_16	74	150
PARAM_17	160	160
PARAM_18	0	1
PARAM_19	12	12
PARAM_20	15600	15600
PARAM_21	256	256
PARAM_22	0	1
PARAM_23	0	3
PARAM_24	0	1
PARAM_25	0	14

By default, the wrist configuration is available for use. If the platform is a wrist operated device, then there is no need to overwrite the step counter parameter values. If the configuration needs to be modified then the following steps must be followed:

1. Disable step counter, step detector, and activity detection
2. Modify the 25 parameters of step counter
3. Enable step counter, step detector, and activity detection

After re-enabling the features, the new parameters value will be used.

#### Customized Step Counter Sensitivity Configuration (overwrites Step Counter Presets)

The Step Counter and Detector sensitivity can be modified manually by setting the step counter parameters in the register map with the support of the corresponding field application engineer. The default parameters are set by the step counter preset (phone/wrist) which is used.

Configuration settings:

1. [FEATURES IN.step\\_counter.settings 26.watermark level](#) - Watermark level; the Step-counter will trigger output every time this number of steps are counted. Holds implicitly a 20x factor, so the range is 0 to 20460, with resolution of 20 steps. If 0, the Step Counter watermark is disabled and Step Detector enabled.
2. [FEATURES IN.step\\_counter.settings 26.reset counter](#) – flag to reset the counted steps. This is only interpreted if the step counter is enabled.
3. [FEATURES IN.step\\_counter.settings 26.en counter](#) – indicates if the Step Counter feature is enabled or not.
4. [FEATURES IN.step\\_counter.settings 26.en detector](#) – indicates if the Step Detector feature is enabled or not.

[FEATURES IN.step\\_counter.settings 1.param 1](#) – there are 25 parameters, which configure the use case (wrist or phone).

### **Walking activity recognition**

This feature can detect the actual walking activity status of a user. It can distinguish between walking, running and still.

The change of the status can be read in [INT STATUS 0.activity type out](#); the status itself can be read in [ACTIVITY TYPE.activity type out](#). The walking activity recognition can be enabled by [FEATURES IN.step counter.settings 26.en activity](#). Step counter has to be enabled as well by [FEATURES IN.step counter settings 26.en counter](#).

#### Configuration settings:

[FEATURES IN.step counter.settings 26.en activity](#) – enables walking activity recognition.

### Tilt on Wrist

How to perform the “Tilt on Wrist” gesture ideally:

1. Wrap the device on your wrist.
2. Lift the hand wearing the device up to a comfortable position and tilt it to minimum 12° to gravity (see the image below for the valid position)
3. Wait for a second.

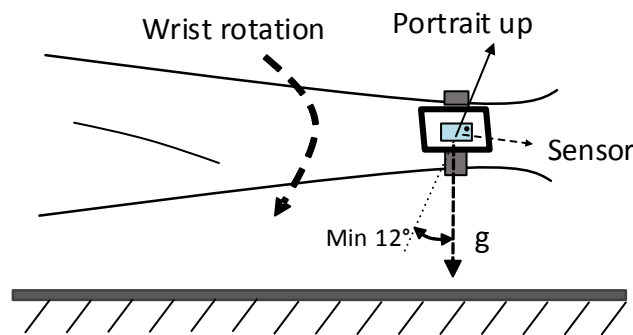

Valid position for Tilt on Wrist

The Tilt on Wrist Interrupt is detected with one accelerometer axis. Therefore, you should make sure that the active axis is mapped to the portrait up direction of the device by using the axis remapping functionality of BMA425. See the examples in the table below.

The table below shows the required remapping configurations for the Tilt on Wrist function based on the sensor’s different orientations inside the device. More information about how to remap the axis direction can be found in the general interrupt description in Chapter 4.6.

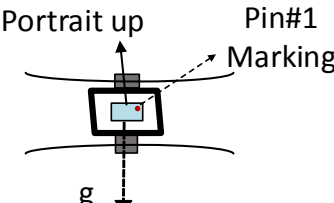
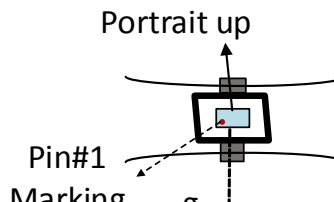
No.	Sensor direction	Mount layer	Register configuration	Remarks
1	Portrait up 	Top layer	map_x_axis = 0 map_x_axis_sign = 0 map_y_axis = 1 map_y_axis_sign = 0 map_z_axis = 2 map_z_axis_sign = 0	X = +x axis Y = +y axis Z = +z axis  Same as the original mapping
2	Portrait up 	Top layer	map_x_axis = 0 map_x_axis_sign = 1 map_y_axis = 1 map_y_axis_sign = 1 map_z_axis = 2 map_z_axis_sign = 0	X = -x axis Y = -y axis Z = +z axis  x, y inverted

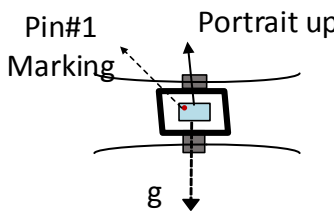
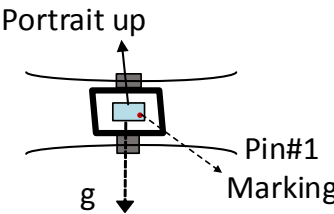
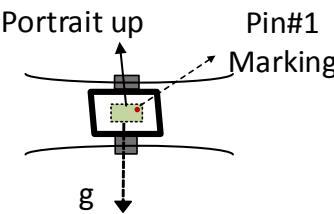
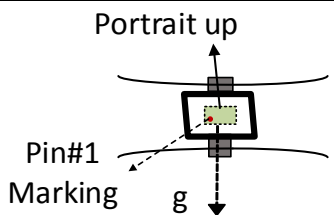
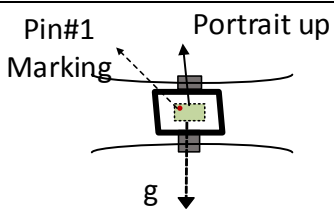
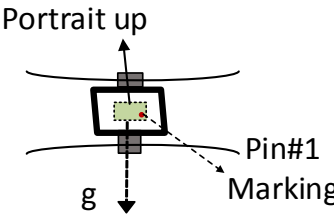
3		Top layer	$\text{map\_x\_axis} = 1$ $\text{map\_x\_axis\_sign} = 1$ $\text{map\_y\_axis} = 0$ $\text{map\_y\_axis\_sign} = 0$ $\text{map\_z\_axis} = 2$ $\text{map\_z\_axis\_sign} = 0$	$X = -y$ axis $Y = +x$ axis $Z = +z$ axis  x, y swapped, and y inverted
4		Top layer	$\text{map\_x\_axis} = 1$ $\text{map\_x\_axis\_sign} = 0$ $\text{map\_y\_axis} = 0$ $\text{map\_y\_axis\_sign} = 1$ $\text{map\_z\_axis} = 2$ $\text{map\_z\_axis\_sign} = 0$	$X = +y$ axis $Y = -x$ axis $Z = +z$ axis  x, y swapped, and x inverted
5		Bottom layer	$\text{map\_x\_axis} = 1$ $\text{map\_x\_axis\_sign} = 0$ $\text{map\_y\_axis} = 0$ $\text{map\_y\_axis\_sign} = 0$ $\text{map\_z\_axis} = 2$ $\text{map\_z\_axis\_sign} = 1$	$X = y$ axis $Y = x$ axis $Z = -z$ axis  x, y swapped, and z inverted
6		Bottom layer	$\text{map\_x\_axis} = 1$ $\text{map\_x\_axis\_sign} = 1$ $\text{map\_y\_axis} = 0$ $\text{map\_y\_axis\_sign} = 1$ $\text{map\_z\_axis} = 2$ $\text{map\_z\_axis\_sign} = 1$	$X = -y$ axis $Y = -x$ axis $Z = -z$ axis  x, y swapped, and x, y, z inverted
7		Bottom layer	$\text{map\_x\_axis} = 0$ $\text{map\_x\_axis\_sign} = 1$ $\text{map\_y\_axis} = 1$ $\text{map\_y\_axis\_sign} = 0$ $\text{map\_z\_axis} = 2$ $\text{map\_z\_axis\_sign} = 1$	$X = -x$ axis $Y = y$ axis $Z = -z$ axis  x, z inverted
8		Bottom layer	$\text{map\_x\_axis} = 0$ $\text{map\_x\_axis\_sign} = 0$ $\text{map\_y\_axis} = 1$ $\text{map\_y\_axis\_sign} = 1$ $\text{map\_z\_axis} = 2$ $\text{map\_z\_axis\_sign} = 1$	$X = x$ axis $Y = -y$ axis $Z = -z$ axis  y, z inverted

### Configuration settings

[FEATURES\\_IN.wrist\\_tilt.settings.enable](#) – enables/disables the Tilt on Wrist feature.



## Double tap / Tap detection

The gesture “Tap / Double tap” can be enabled by [FEATURES\\_IN.tap\\_doubletap.settings.enable](#). The detection is done by measuring the acceleration on z-direction.

By default double tap detection is enabled. To enable single tap detection (and disable double tap), you can configure the parameter: [FEATURES\\_IN.tap\\_doubletap.settings.single\\_tab\\_en](#) – 1 bit – flag.

The detection sensitivity can be customized using the register [FEATURES\\_IN.tap\\_doubletap.settings.sensitivity](#). The sensitivity range is from 0 (high) to 7 (low).

How to perform the gesture ideally:

1. Use your index finger to tapon the device slightly harder than how you touch a button on a touchscreen.
2. Tap again directly, if “Double tap” detection is enabled.
3. Wait for half a second.

### Configuration settings

1. [FEATURES\\_IN.tap\\_doubletap.settings.enable](#)– enables/disables the Wakeup feature.
2. [FEATURES\\_IN.tap\\_doubletap.settings.sensitivity](#)– configures the detection sensitivity which ranges from 0 (high) to 7 (low).
3. [FEATURES\\_IN.tap\\_doubletap.settings.single\\_tab\\_en](#)- enables single tap detection. By default, double tap is enabled.

## Any Motion / No motion detection

### Any Motion Detection:

The any-motion detection uses the slope between two acceleration signals to detect changes in motion. The interrupt is configured by setting at least one of the following flags: [FEATURES IN.any motion.settings 2.en x](#), [FEATURES IN.any motion.settings 2.en y](#) and [FEATURES IN.any motion.settings 2.en z](#), respectively for each axis.

It generates an interrupt when the absolute value of the slope (the difference between two accelerations) exceeds the preset [FEATURES IN.any motion.settings 1.threshold](#) for a certain number, [FEATURES IN.any motion.settings 2.duration](#), of consecutive data points.

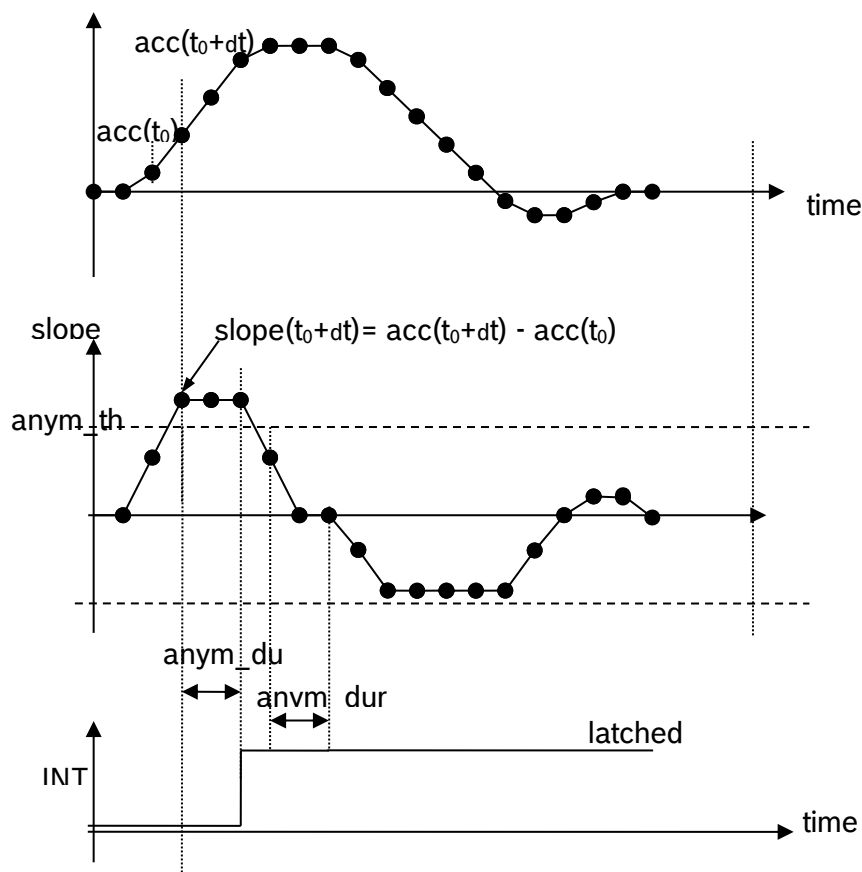

Any-motion (slope) interrupt detection

The slope (difference) is being computed between the current acceleration sample and the reference sample. The reference sample is updated while the Anymotion is detected; basically this means the reference is the last state when sensor detected Anymotion.

If the same number of data points falls below the [FEATURES IN.any motion.settings 1.threshold](#), the interrupt is reset.



### No Motion Detection:

The interrupt engine can also be configured as a No-motion interrupt, when register [FEATURES\\_IN.any\\_motion.settings\\_1.nomotion\\_sel](#) is set.

No-motion is generated when the slope on all selected axis remains smaller than a programmable [FEATURES\\_IN.any\\_motion.settings\\_1.threshold](#) for a programmable time. The signals and timings relevant to the no-motion interrupt functionality are depicted in the figure below.

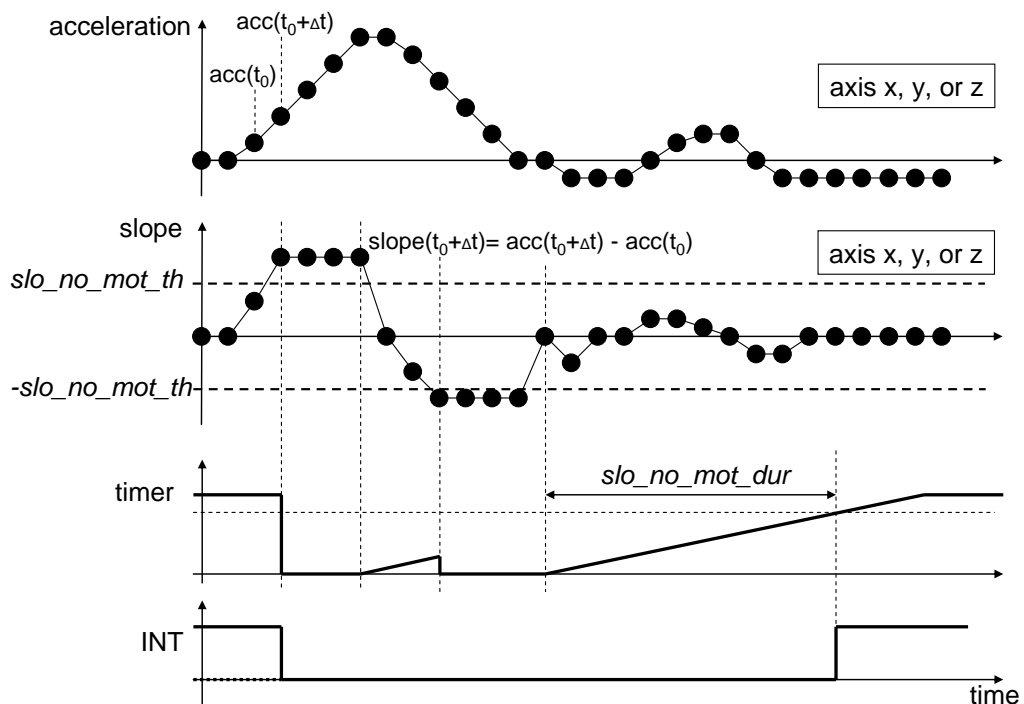

Figure 1 Signal timings No-motion interrupt

Register [FEATURES\\_IN.any\\_motion.settings\\_2.duration](#) defines the number of consecutive slope data points of the selected axis which must exceed the threshold for an interrupt to be asserted.

### Configuration settings:

1. [FEATURES\\_IN.any\\_motion.settings\\_2.duration](#) – the number of consecutive data points for which the threshold condition must be respected, for interrupt assertion.
2. [FEATURES\\_IN.any\\_motion.settings\\_1.threshold](#) – the slope threshold.
3. [FEATURES\\_IN.any\\_motion.settings\\_2.en\\_x](#) – indicates if this feature is enabled for x axis
4. [FEATURES\\_IN.any\\_motion.settings\\_2.en\\_y](#) – indicates if this feature is enabled for y axis
5. [FEATURES\\_IN.any\\_motion.settings\\_2.en\\_z](#) – indicates if this feature is enabled for z axis
6. [FEATURES\\_IN.any\\_motion.settings\\_1.nomotion\\_sel](#) – indicates if No-motion (1) or Any-motion (0) is selected.

## 4.7. General Interrupt Pin configuration

### Electrical Interrupt Pin Behavior

Both interrupt pins INT1 and INT2 can be configured to show the desired electrical behavior. Interrupt pins can be enabled in [INT1 IO CTRL.output en](#) respectively [INT2 IO CTRL.output en](#). The characteristic of the output driver of the interrupt pins may be configured with bits [INT1 IO CTRL.od](#) and [INT2 IO CTRL.od](#). By setting these bits to 0b1, the output driver shows open-drive characteristic, by setting the configuration bits to 0b0, the output driver shows push-pull characteristic.

The electrical behavior of the Interrupt pins, whenever an interrupt is triggered, can be configured as either “active-high” or “active-low” via [INT1 IO CTRL.lv](#) respectively [INT2 IO CTRL.lv](#).

Both interrupt pins can be configured as input pins via [INT1 IO CTRL.input en](#) respectively [INT2 IO CTRL.input en](#). This is necessary when FIFO tag feature is used (see chapter 0). If both are enabled, the input (e.g. marking FIFO) is driven by the interrupt output. BMA425 supports edge and level triggered interrupt inputs, this can be configured through [INT1 IO CTRL.edge ctrl](#) respectively [INT2 IO CTRL.edge ctrl](#).

BMA425 supports non-latched and latched interrupts modes for data-ready, FIFO full and FIFO watermark. The mode is selected by [INT LATCH.int latch](#). The feature interrupts described in chapter 4.6 support only latched mode described below.

In latched mode an asserted interrupt status in [INT STATUS 0](#) or [INT STATUS 1](#) and the selected pin are cleared if the corresponding status register is read. If more than one interrupt pin is used in latched mode, all interrupts in [INT STATUS 0](#) should be mapped to one pin and all interrupts in [INT STATUS 1](#) should be mapped to the other pin. If just one interrupt pin is used all interrupts may be mapped to this pin. If the activation condition still holds when it is cleared, the interrupt status is asserted again when the interrupt condition holds again.

In the non-latched mode (only for data-ready, FIFO full and FIFO watermark) the interrupt status bit and the selected pin are reset as soon as the activation condition is not valid anymore.

### Interrupt Pin Mapping

In order, for the Host to react to the features output, they can be mapped to the external PIN1 or PIN2, by setting the corresponding bits from the registers [INT1 MAP](#), respectively [INT2 MAP](#).

To disconnect the features outputs to the external pins, the same corresponding bits must be reset, from the registers, [INT1 MAP](#), respectively [INT2 MAP](#).

Once a feature triggered the output pin, the Host can read out the corresponding bit from the register, [INT STATUS 0](#) (Feature Interrupts) or [INT STATUS 1](#) (FIFO and data ready).

#### 4.8. Auxiliary Sensor Interface

The auxiliary interface allows to attach one auxiliary sensor (e.g. magnetometer) on dedicated auxiliary sensor interface as shown in Figure...

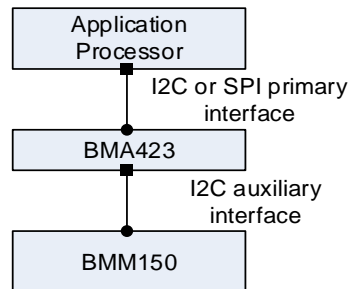

6-DOF Solution w/ BMA425 and BMM150

#### Structure and Concept

The BMA425 controls the data acquisition of the auxiliary sensor and presents the data to the application processor through the primary I2C or SPI interface. No other I2C master or slave devices must be attached to the auxiliary sensor interface.

The BMA425 autonomously reads the sensor data from a compatible auxiliary sensor without intervention of the application processor and stores the data in its data registers and FIFO. The initial setup of the auxiliary sensor after power-on is done through indirect addressing.

The main benefits of the auxiliary sensor interface are

- Synchronization of sensor data of auxiliary sensor and accelerometer. This results in an improved sensor data fusion quality.
- Usage of the BMA425 FIFO for auxiliary sensor data (BMM150 does not have a FIFO). This is important for monitoring applications.

#### Interface Configuration

The configuration registers that control the auxiliary sensor interface operation, are only affecting the interface to the auxiliary sensor, not the configuration of the sensor itself (this must be done in setup mode).

There are three basis configurations of the auxiliary sensor interface:

- No auxiliary sensor access
- Setup mode: Auxiliary sensor access in manual mode
- Data mode: Auxiliary sensor access through hardware readout loop.

The setup of the auxiliary sensor itself must be done through the primary interface using indirect addressing in setup mode. When collecting sensor data, the BMA425 autonomously triggers the

measurement of the auxiliary sensor using the auxiliary sensor forced mode and the data readout from the auxiliary sensor (data mode).

In setup mode, the auxiliary sensor may be configured and trim data may be read out from the auxiliary sensor. In the data mode the auxiliary sensor data are continuously copied into BMA425 registers and may be read out from BMA425 directly over the primary interface. For a BMM150 magnetometer, these are the auxiliary sensor data itself and Hall resistance, temperature is not required. The table below shows how to configure these three modes using the registers [PWR\\_CONF](#), [PWR\\_CTRL](#), and [AUX\\_IF\\_CONF.aux\\_manual\\_en](#).

Mode	<a href="#">AUX_IF_CONF.aux_manual_en</a>	<a href="#">PWR_CONF.adv_power_save</a>	<a href="#">PWR_CTRL.aux_en</a>
No auxiliary sensor access	1	1	0
Setup mode	1	0	0
Data mode	0	x	1

The auxiliary sensor interface mode may be enabled by setting bit [IF\\_CONF.if\\_mode](#) according to the following table.

<a href="#">IF_CONF.if_mode</a>	Result
0	Secondary IF disabled (default)
1	AuxIF enabled

The auxiliary sensor interface operates at 400 kHz. This results in an I2C readout delay of about 250 us for 10 bytes of data.

### Setup mode ([AUX\\_IF\\_CONF.aux\\_manual\\_en](#) =0b1)

Through the primary interface the auxiliary sensor may be accessed using indirect addressing through the [AUX\\_\\*](#) registers. [AUX\\_RD\\_ADDR](#) and [AUX\\_WR\\_ADDR](#) define the address of the register to read/write in the auxiliary sensor register map and triggers the operation itself, when the auxiliary sensor interface is enabled through [PWR\\_CTRL.aux\\_en](#).

For reads, the number of data bytes defined in [AUX\\_IF\\_CONF.aux\\_rd\\_burst](#) are read from the auxiliary sensor and written into the BMA425 Register [DATA\\_0](#) to [DATA\\_7](#). For writes only single bytes are written, independent of the settings in [AUX\\_IF\\_CONF.aux\\_rd\\_burst](#). The data for the I2C write to auxiliary sensor must be stored in [AUX\\_WR\\_DATA](#) before the auxiliary sensor register address is written into [AUX\\_WR\\_ADDR](#).

When a read or write operation is triggered by writing to [AUX\\_RD\\_ADDR](#) and [AUX\\_WR\\_ADDR](#), [STATUS.aux\\_man\\_op](#) is set and it is reset when the operation is completed. For reads the [DATA\\_0](#) to [DATA\\_7](#) contains the read data, for writes [AUX\\_WR\\_DATA](#) may be overwritten again.



Configuration phase of the auxiliary sensor.

Example: Read bytes 5 and 6 of auxiliary sensor

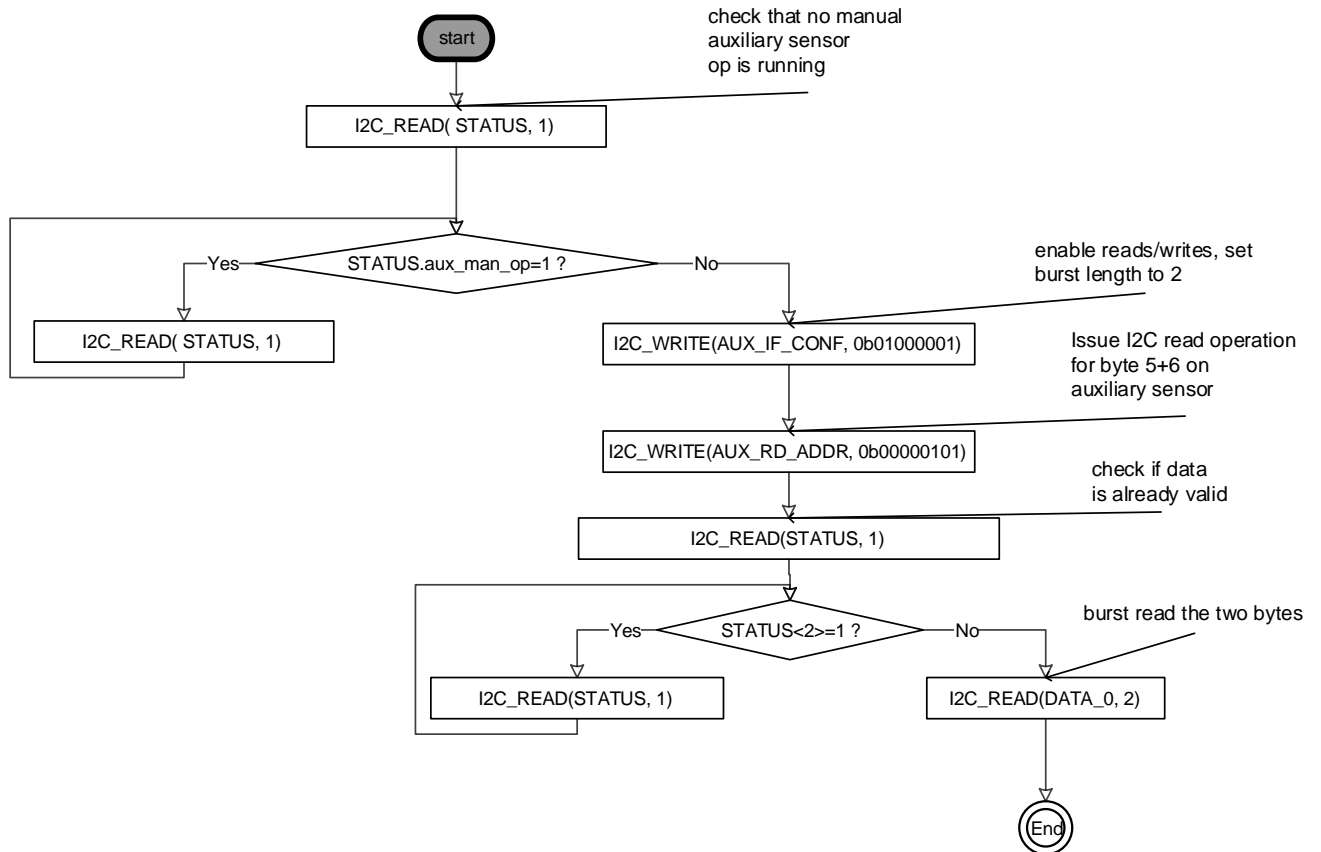



Example: Write 0xEF into byte 3 of auxiliary sensor

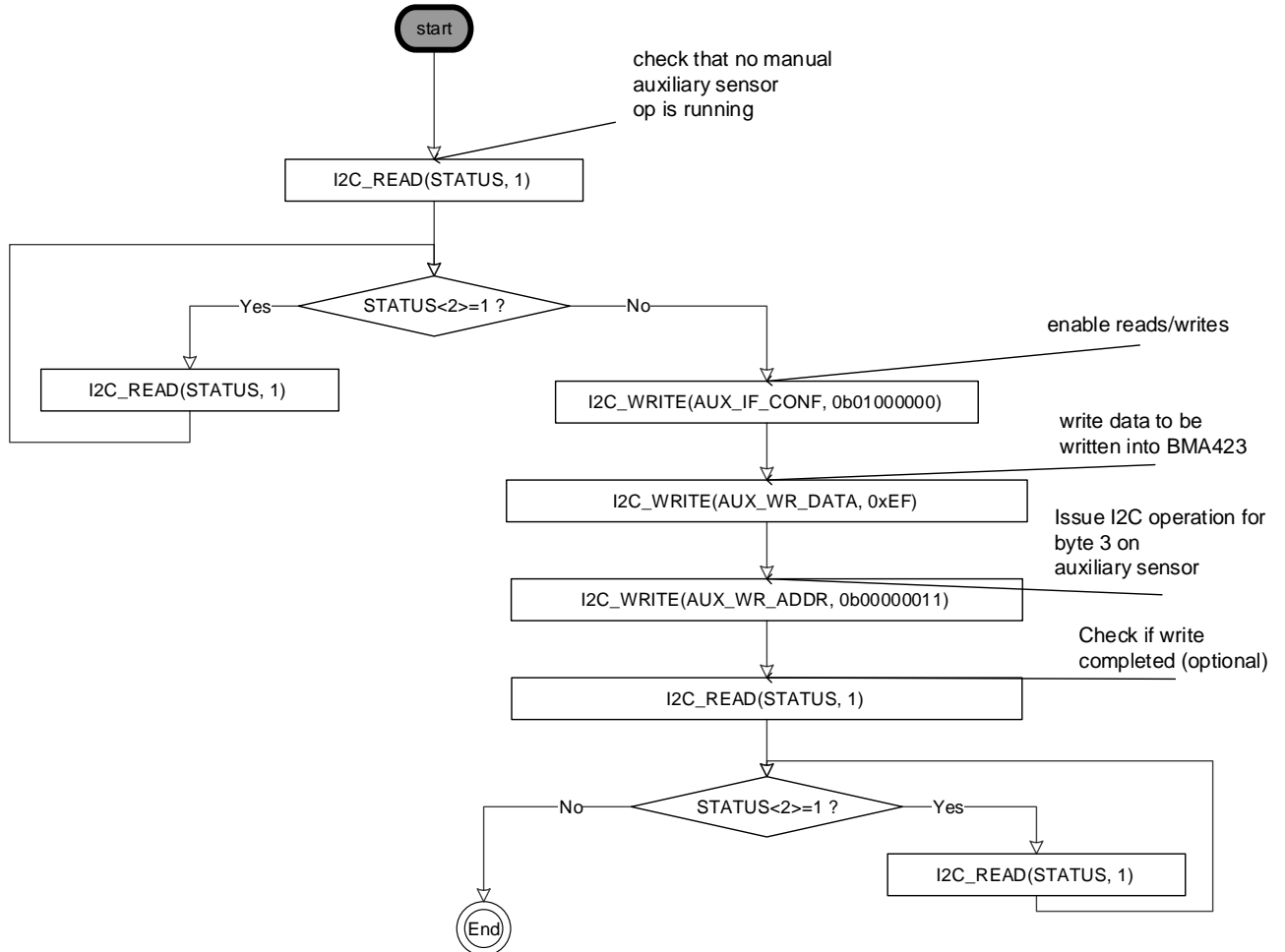

**Data mode ([AUX\\_IF\\_CONF.aux\\_manual\\_en=0](#))**

[AUX\\_RD\\_ADDR.read\\_addr](#) defines the address of the data register from which to read the number of data bytes configured in [AUX\\_IF\\_CONF.aux\\_rd\\_burst](#) from AUX\_0... AUX\_7 data of the auxiliary sensor. These data are stored in the [DATA\\_0](#) up to [DATA\\_7](#) register. The data ready status is set in [STATUS.drdy\\_aux](#), it is typically cleared through reading one of the [DATA\\_0](#) to [DATA\\_7](#) registers.

[AUX\\_WR\\_ADDR.write\\_addr](#) defines the register address of auxiliary sensor to start a measurement in forced mode in the auxiliary sensor register map. The delay (time offset) between triggering an auxiliary sensor measurement and reading the measurement data is specified in [AUX\\_CONF.aux\\_offset](#). Reading of the data is done in a single I2C read operation with a burst length specified in [AUX\\_IF\\_CONF.aux\\_rd\\_burst](#). For BMM150 [AUX\\_IF\\_CONF.aux\\_rd\\_burst](#) should be set to 0b11, i.e. 8 bytes. If [AUX\\_IF\\_CONF.aux\\_rd\\_burst](#) is set to a value lower than 8 bytes, the remaining auxiliary sensor data in the Register [DATA\\_0](#) to [DATA\\_7](#) and the FIFO are undefined.

It is recommended to disable the auxiliary sensor interface ([IF\\_CONF.if\\_mode=0b0](#)) before setting up [AUX\\_RD\\_ADDR.read\\_addr](#) and [AUX\\_WR\\_ADDR.write\\_addr](#) for the data mode. This does not put the auxiliary sensor itself into suspend mode but avoids gathering unwanted data during this phase. Afterwards the auxiliary sensor interface can be enabled ([IF\\_CONF.if\\_mode=0b1](#)) again.

**Delay (Time Offset)**

BMA425 supports starting the measurement of the sensor at the auxiliary sensor interface between 2.5 and 37.5 ms before the Register DATA are updated. This offset is defined in [AUX\\_CONF.aux\\_offset](#). If set to 0b0, the measurement is done right after the last Register DATA update, therefore this measurement will be included in the next register DATA update.

#### 4.9. Sensor Self-Test

The BMA425 has a comprehensive self test function for the MEMS element by applying electrostatic forces to the sensor core instead of external accelerations. By actually deflecting the seismic mass, the entire signal path of the sensor can be tested. Activating the self-test results in a static offset of the acceleration data; any external acceleration or gravitational force applied to the sensor during active self-test will be observed in the output as a superposition of both acceleration and self-test signal.

Before the self-test is enabled the g-range should be set to 8g. The self-test is activated for all axes by writing [ACC\\_SELF\\_TEST.acc\\_self\\_test\\_en](#) = 1b1. The self-test is disabled by writing [ACC\\_SELF\\_TEST.acc\\_self\\_test\\_en](#) = 1b0. It is possible to control the direction of the deflection through bit [ACC\\_SELF\\_TEST.acc\\_self\\_test\\_sign](#). The excitation occurs in positive (negative) direction if [ACC\\_SELF\\_TEST.acc\\_self\\_test\\_sign](#)= 1b1 ('b0). The amplitude of the deflection has to be set high by writing [ACC\\_SELF\\_TEST.acc\\_self\\_test\\_amp](#) = 1b1. After the self-test is enabled, the user should wait 50ms before interpreting the acceleration data.

In order to ensure a proper interpretation of the self-test signal it is recommended to perform the self-test for both (positive and negative) directions and then to calculate the difference of the resulting acceleration values. The table below shows the minimum differences for each axis in order for the self test to pass. The actually measured signal differences can be significantly larger.

Self-test: Resulting minimum difference signal for BMA425.

	x-axis signal	y-axis signal	z-axis signal
BMA425	400 mg	800 mg	400 mg

It is recommended to perform a reset of the device after a self-test has been performed. If the reset cannot be performed, the following sequence must be kept to prevent unwanted interrupt generation: disable interrupts, change parameters of interrupts, wait for at least 50ms, and enable desired interrupts.

The recommended self test procedure is as follows:

1. Enable accelerometer with register [PWR\\_CTRL.acc\\_en](#)=1b1.
2. Set ±8g range in register [ACC\\_RANGE.acc\\_range](#)
3. Set self test amplitude to high by setting [ACC\\_SELF\\_TEST.acc\\_self\\_test\\_amp](#) = 1b1
4. Set [ACC\\_CONF.acc\\_odr=1600Hz](#), Continuous sampling mode, [ACC\\_CONF.acc\\_bwp](#)=norm\_avg4, [ACC\\_CONF.acc\\_perf\\_mode](#)=1b1.
5. Wait for > 2 ms
6. Enable self-test and set positive self-test polarity ([ACC\\_SELF\\_TEST.acc\\_self\\_test\\_sign](#)= 1b1)
7. Wait for > 50ms
8. Read and store positive acceleration value of each axis from registers [DATA\\_8](#) to [DATA\\_13](#)
9. Enable self-test and set negative self-test polarity [ACC\\_SELF\\_TEST.acc\\_self\\_test\\_sign](#)= 1b0)
10. Wait for > 50ms
11. Read and store negative acceleration value of each axis from registers [DATA\\_8](#) to [DATA\\_13](#)
12. Calculate difference of positive and negative acceleration values and compare against threshold values



#### 4.10. Offset Compensation

BMA425 offers manual compensation as well as inline calibration.

Offset compensation is performed with pre-filtered data, and the offset is then applied to both, pre-filtered and filtered data. If necessary the result of this computation is saturated to prevent any overflow errors (the smallest or biggest possible value is set, depending on the sign).

The public offset compensation Registers [OFFSET 0](#) to [OFFSET 2](#) are images of the corresponding registers in the NVM. With each image update the contents of the NVM registers are written to the public registers. The public registers can be overwritten by the user at any time.

The offset compensation registers have a width of 8 bit using two's complement notation. The offset resolution (LSB) is 3.9 mg and the offset range is +- 0.5 g. Both are independent of the range setting. Offset compensation needs to be enabled through [NV\\_CONF.acc\\_off\\_en](#) = 0b1

##### Manual Offset Compensation

The contents of the public compensation Register [OFFSET 0](#) to [OFFSET 2](#) may be set manually via the digital interface. After modifying the Register [OFFSET 0](#) to [OFFSET 2](#) the next data sample is not valid.

Offset compensation needs to be enabled through [NV\\_CONF.acc\\_off\\_en](#).

##### Inline Calibration

For certain applications, it is often desirable to calibrate the offset once and to store the compensation values permanently. This can be achieved by using manual offset compensation to determine the proper compensation values and then storing these values permanently in the NVM.

Each time the device is reset, the compensation values are loaded from the non-volatile memory into the image registers and used for offset compensation.

#### 4.11. Non-Volatile Memory

The registers [NV\\_CONF](#) and [OFFSET\\_0](#) to [OFFSET\\_2](#) have an NVM backup which are accessible by the user.

The content of the NVM is loaded to the image registers after a reset (either POR or softreset). As long as the image update is in progress, [STATUS.cmd\\_rdy](#) is 0b0, otherwise it is 0b1.

The image registers can be read and written like any other register.

Writing to the NVM is a 4-step procedure:

1. Set [PWR\\_CONF.adv\\_power\\_save](#) = 0b0
2. Write the new contents to the image registers.
3. Write 0b1 to bit [NVM\\_CONF.nvm\\_prog\\_en](#) in order to unlock the NVM.
4. Write *prog\_nvm* to the [CMD](#) register to trigger the write process.

Writing to the NVM always renews the entire NVM contents. It is possible to check the write status by reading [STATUS.cmd\\_rdy](#). While [STATUS.cmd\\_rdy](#) = 0b0, the write process is still in progress; when [STATUS.cmd\\_rdy](#) = 0b1, writing is completed. An NVM write cycle can only be initiated, if [PWR\\_CONF.adv\\_power\\_save](#) = 0b0.

Until boot phase is finished (after POR or softreset), the serial interface is not operational. The NVM shadow registers must not be accessed during an ongoing NVM command (initiated through the Register [CMD](#)). In all other cases, register can be read or written.

As long as an NVM read (during sensor boot and soft reset) or an NVM write is ongoing, writes to sensor registers are discarded, reads return the Register [STATUS](#) independent of the read address.

#### 4.12. Soft-Reset

A softreset can be initiated at any time by writing the command *softreset* (0xB6) to register [CMD](#). The softreset performs a fundamental reset to the device which is largely equivalent to a power cycle. Following a delay, all user configuration settings are overwritten with their default state (setting stored in the NVM) wherever applicable. This command is functional in all operation modes but must not be performed while NVM writing operation is in progress.

## 5. Register Description

### 5.1. General Remarks

Registers can be read and written in all power configurations with the exception of [FEATURES\\_IN](#) and [FIFO\\_DATA](#) which need [PWR\\_CONF.adv\\_power\\_save](#) set to 0b0.

### 5.2. Register Map

read/write	read only	write only	reserved
------------	-----------	------------	----------

Register Address	Register Name	Default Value	7	6	5	4	3	2	1	0
0x7E	<a href="#">CMD</a>	0x00	cmd							
0x7D	<a href="#">PWR_CTL</a>	0x00	reserved					acc_en	reserved	aux_en
0x7C	<a href="#">PWR_CONF</a>	0x03	reserved						fifo_self_wakeup	adv_power_save
0x7B	-	-	reserved							
...	-	-	reserved							
0x74	-	-	reserved							
0x73	<a href="#">OFFSET_2</a>	0x00	off_acc_z							
0x72	<a href="#">OFFSET_1</a>	0x00	off_acc_y							
0x71	<a href="#">OFFSET_0</a>	0x00	off_acc_x							
0x70	<a href="#">NV_CONF</a>	0x00	reserved				acc_off_en	i2c_wdt_en	i2c_wdt_sel	spi_en
0x6F	-	-	reserved							
0x6E	-	-	reserved							
0x6D	<a href="#">ACC_SELF_TEST_I</a>	0x00	reserved				acc_self_test_amp	acc_self_test_sign	reserved	acc_self_test_en
0x6C	-	-	reserved							
0x6B	<a href="#">IF_CONF</a>	0x00	reserved			if_mode	reserved			spi3
0x6A	<a href="#">NVM_CONF</a>	0x00	reserved						nvm_prog_en	reserved
0x69	-	-	reserved							
...	-	-	reserved							
0x60	-	-	reserved							

0x5F	<a href="#">INTERN AL_ERR OR</a>	0x00	reserved					int_err_2	int_err_1	reserved	
0x5E	<a href="#">FEATUR ES_IN</a>	0x00	features_in								
0x5D	-	-	reserved								
...	-	-	reserved								
0x5A	-	-	reserved								
0x59	<a href="#">INIT_CT RL</a>	0x90	init_ctrl								
0x58	<a href="#">INT_MA P_DATA</a>	0x00	reserved	int2_drdy	int2_fwm	int2_full	reserved	int1_drdy	int1_fwm	int1_full	
0x57	<a href="#">INT2_MA P</a>	0x00	error_int_out	any_no_motion_out	wakeup_out	reserved	wrist_tilt_out	activity_type_out	step_counter_out	reserved	
0x56	<a href="#">INT1_MA P</a>	0x00	error_int_out	any_no_motion_out	wakeup_out	reserved	wrist_tilt_out	activity_type_out	step_counter_out	reserved	
0x55	<a href="#">INT_LAT CH</a>	0x00	reserved							int_latch	
0x54	<a href="#">INT2_IO CTRL</a>	0x00	reserved			input_en	output_en	od	lvl	edge_ctrl	
0x53	<a href="#">INT1_IO CTRL</a>	0x00	reserved			input_en	output_en	od	lvl	edge_ctrl	
0x52	-	-	reserved								
...	-	-	reserved								
0x50	-	-	reserved								
0x4F	<a href="#">AUX_W R_DATA</a>	0x02	write_data								
0x4E	<a href="#">AUX_W R_ADDR</a>	0x4C	write_addr								
0x4D	<a href="#">AUX_RD ADDR</a>	0x42	read_addr								
0x4C	<a href="#">AUX_IF CONF</a>	0x83	aux_man ual_en	reserved					aux_rd_burst		
0x4B	<a href="#">AUX_DE V_ID</a>	0x20	i2c_device_addr							reserved	
0x4A	-	-	reserved								
0x49	<a href="#">FIFO_C ONFIG 1</a>	0x10	reserved	fifo_acc_en	fifo_aux_en	fifo_head_er_en	fifo_tag_int1_en	fifo_tag_int2_en	reserved		
0x48	<a href="#">FIFO_C ONFIG 0</a>	0x02	reserved						fifo_time_en	fifo_stop_on_full	



0x47	<a href="#">FIFO_W TM_1</a>	0x02	reserved			fifo_water_mark_12_8		
0x46	<a href="#">FIFO_W TM_0</a>	0x00	fifo_water_mark_7_0					
0x45	<a href="#">FIFO_D OWNS</a>	0x80	acc_fifo_ filt_data	acc_fifo_downs			reserved	
0x44	<a href="#">AUX_CO NF</a>	0x46	aux_offset				aux_odr	
0x43	-	-	reserved					
0x42	-	-	reserved					
0x41	<a href="#">ACC_RA NGE</a>	0x01	reserved					acc_range
0x40	<a href="#">ACC_CO NF</a>	0xA8	acc_perf_ _mode	acc_bwp			acc_odr	
0x3F	-	-	reserved					
...	-	-	reserved					
0x2B	-	-	reserved					
0x2A	<a href="#">INTERN AL_STAT US</a>	0x00	odr_high_ _error	odr_50hz_ _error	axes_re map_err or	message		
0x29	-	-	reserved					
0x28	-	-	reserved					
0x27	<a href="#">ACTIVIT Y_TYPE</a>	0x00	reserved					activity_type_out
0x26	<a href="#">FIFO_DA TA</a>	0x00	fifo_data					
0x25	<a href="#">FIFO_LE NGTH_1</a>	0x00	reserved			fifo_byte_counter_13_8		
0x24	<a href="#">FIFO_LE NGTH_0</a>	0x00	fifo_byte_counter_7_0					
0x23	-	-	reserved					
0x22	<a href="#">TEMPER ATURE</a>	0x00	temperature					
0x21	<a href="#">STEP_C OUNTER _3</a>	0x00	step_counter_out_3					
0x20	<a href="#">STEP_C OUNTER _2</a>	0x00	step_counter_out_2					
0x1F	<a href="#">STEP_C OUNTER _1</a>	0x00	step_counter_out_1					

0x1E	<a href="#">STEP_COUNTER_0</a>	0x00	step_counter_out_0								
0x1D	<a href="#">INT_STATUS_1</a>	0x00	acc_drdy_int	reserved	aux_drdy_int	reserved			fwm_int	full_int	
0x1C	<a href="#">INT_STATUS_0</a>	0x00	error_int_out	any_no_motion_out	wakeup_out	reserved	wrist_tilt_out	activity_type_out	step_counter_out	reserved	
0x1B	<a href="#">EVENT</a>	0x01	reserved								por_detected
0x1A	<a href="#">SENSOR_TIME_2</a>	0x00	sensor_time_23_16								
0x19	<a href="#">SENSOR_TIME_1</a>	0x00	sensor_time_15_8								
0x18	<a href="#">SENSOR_TIME_0</a>	0x00	sensor_time_7_0								
0x17	<a href="#">DATA_13</a>	0x00	acc_z_11_4								
0x16	<a href="#">DATA_12</a>	0x00	acc_z_3_0				reserved				
0x15	<a href="#">DATA_11</a>	0x00	acc_y_11_4								
0x14	<a href="#">DATA_10</a>	0x00	acc_y_3_0				reserved				
0x13	<a href="#">DATA_9</a>	0x00	acc_x_11_4								
0x12	<a href="#">DATA_8</a>	0x00	acc_x_3_0				reserved				
0x11	<a href="#">DATA_7</a>	0x00	aux_r_11_4								
0x10	<a href="#">DATA_6</a>	0x00	aux_r_3_0				reserved				
0x0F	<a href="#">DATA_5</a>	0x00	aux_z_11_4								
0x0E	<a href="#">DATA_4</a>	0x00	aux_z_3_0				reserved				
0x0D	<a href="#">DATA_3</a>	0x00	aux_y_11_4								
0x0C	<a href="#">DATA_2</a>	0x00	aux_y_3_0				reserved				
0x0B	<a href="#">DATA_1</a>	0x00	aux_x_11_4								
0x0A	<a href="#">DATA_0</a>	0x00	aux_x_3_0				reserved				
0x09	-	-	reserved								
...	-	-	reserved								
0x04	-	-	reserved								
0x03	<a href="#">STATUS</a>	0x10	drdy_acc	reserved	drdy_aux	cmd_rdy	reserved	aux_man_op	reserved		
0x02	<a href="#">ERR_REG</a>	0x00	aux_err	fifo_err	reserved	error_code			cmd_err	fatal_err	
0x01	-	-	reserved								
0x00	<a href="#">CHIP_ID</a>	0x13	chip_id								

## FEATURES\_IN

Register Address	Register Name	Default Value	7	6	5	4	3	2	1	0
------------------	---------------	---------------	---	---	---	---	---	---	---	---



0x5E: 0x3F	<a href="#">general settings axes remapping[1]</a>	0x00	reserved					map_z_axis axis_sign
0x5E: 0x3E	<a href="#">general settings axes remapping[0]</a>	0x88	map_z_axis	map_y_axis axis_sign	map_y_axis	map_x_axis axis_sign	map_x_axis	
0x5E: 0x3D	<a href="#">general settings config id[1]</a>	0x00	identification					
0x5E: 0x3C	<a href="#">general settings config id[0]</a>	0x00	identification					
0x5E: 0x3B	<a href="#">wrist tilt settings[1]</a>	0x00	reserved					
0x5E: 0x3A	<a href="#">wrist tilt settings[0]</a>	0x00	reserved					enable
0x5E: 0x39	<a href="#">tap double tap settings[1]</a>	0x00	reserved					
0x5E: 0x38	<a href="#">tap double tap settings[0]</a>	0x06	reserved		single_tap_en	sensitivity		enable
0x5E: 0x37	<a href="#">step counter settings 26[1]</a>	0x00	reserved	en_activity	en_counter	en_detector	reset_counter	watermark_level
0x5E: 0x36	<a href="#">step counter settings 26[0]</a>	0x00	watermark_level					
0x5E: 0x35	<a href="#">step counter settings 25[1]</a>	0x00	param_25					
0x5E: 0x34	<a href="#">step counter settings</a>	0x0E	param_25					



	<a href="#">ngs_25[0]</a> 1		
0x5E: 0x33	<a href="#">step_cou</a> <a href="#">nter.setti</a> <a href="#">ngs_24[1]</a> 1	0x00	param_24
0x5E: 0x32	<a href="#">step_cou</a> <a href="#">nter.setti</a> <a href="#">ngs_24[0]</a> 1	0x01	param_24
0x5E: 0x31	<a href="#">step_cou</a> <a href="#">nter.setti</a> <a href="#">ngs_23[1]</a> 1	0x00	param_23
0x5E: 0x30	<a href="#">step_cou</a> <a href="#">nter.setti</a> <a href="#">ngs_23[0]</a> 1	0x03	param_23
0x5E: 0x2F	<a href="#">step_cou</a> <a href="#">nter.setti</a> <a href="#">ngs_22[1]</a> 1	0x00	param_22
0x5E: 0x2E	<a href="#">step_cou</a> <a href="#">nter.setti</a> <a href="#">ngs_22[0]</a> 1	0x01	param_22
0x5E: 0x2D	<a href="#">step_cou</a> <a href="#">nter.setti</a> <a href="#">ngs_21[1]</a> 1	0x01	param_21
0x5E: 0x2C	<a href="#">step_cou</a> <a href="#">nter.setti</a> <a href="#">ngs_21[0]</a> 1	0x00	param_21
0x5E: 0x2B	<a href="#">step_cou</a> <a href="#">nter.setti</a> <a href="#">ngs_20[1]</a> 1	0x3C	param_20
0x5E: 0x2A	<a href="#">step_cou</a> <a href="#">nter.setti</a> <a href="#">ngs_20[0]</a> 1	0xF0	param_20
0x5E: 0x29	<a href="#">step_cou</a> <a href="#">nter.setti</a>	0x00	param_19





	<a href="#">ngs_19[1]</a> ↓		
0x5E: 0x28	<a href="#">step_cou</a> <a href="#">nter.setti</a> <a href="#">ngs_19[0]</a> ↓	0x0C	param_19
0x5E: 0x27	<a href="#">step_cou</a> <a href="#">nter.setti</a> <a href="#">ngs_18[1]</a> ↓	0x00	param_18
0x5E: 0x26	<a href="#">step_cou</a> <a href="#">nter.setti</a> <a href="#">ngs_18[0]</a> ↓	0x01	param_18
0x5E: 0x25	<a href="#">step_cou</a> <a href="#">nter.setti</a> <a href="#">ngs_17[1]</a> ↓	0x00	param_17
0x5E: 0x24	<a href="#">step_cou</a> <a href="#">nter.setti</a> <a href="#">ngs_17[0]</a> ↓	0xA0	param_17
0x5E: 0x23	<a href="#">step_cou</a> <a href="#">nter.setti</a> <a href="#">ngs_16[1]</a> ↓	0x00	param_16
0x5E: 0x22	<a href="#">step_cou</a> <a href="#">nter.setti</a> <a href="#">ngs_16[0]</a> ↓	0x96	param_16
0x5E: 0x21	<a href="#">step_cou</a> <a href="#">nter.setti</a> <a href="#">ngs_15[1]</a> ↓	0x00	param_15
0x5E: 0x20	<a href="#">step_cou</a> <a href="#">nter.setti</a> <a href="#">ngs_15[0]</a> ↓	0x19	param_15
0x5E: 0x1F	<a href="#">step_cou</a> <a href="#">nter.setti</a> <a href="#">ngs_14[1]</a> ↓	0x00	param_14
0x5E: 0x1E	<a href="#">step_cou</a> <a href="#">nter.setti</a>	0x27	param_14



	<a href="#">ngs_14[0]</a> ↓		
0x5E: 0x1D	<a href="#">step_cou</a> <a href="#">nter.setti</a> <a href="#">ngs_13[1]</a> ↓	0x00	param_13
0x5E: 0x1C	<a href="#">step_cou</a> <a href="#">nter.setti</a> <a href="#">ngs_13[0]</a> ↓	0x01	param_13
0x5E: 0x1B	<a href="#">step_cou</a> <a href="#">nter.setti</a> <a href="#">ngs_12[1]</a> ↓	0x46	param_12
0x5E: 0x1A	<a href="#">step_cou</a> <a href="#">nter.setti</a> <a href="#">ngs_12[0]</a> ↓	0x0C	param_12
0x5E: 0x19	<a href="#">step_cou</a> <a href="#">nter.setti</a> <a href="#">ngs_11[1]</a> ↓	0xE6	param_11
0x5E: 0x18	<a href="#">step_cou</a> <a href="#">nter.setti</a> <a href="#">ngs_11[0]</a> ↓	0xEC	param_11
0x5E: 0x17	<a href="#">step_cou</a> <a href="#">nter.setti</a> <a href="#">ngs_10[1]</a> ↓	0x04	param_10
0x5E: 0x16	<a href="#">step_cou</a> <a href="#">nter.setti</a> <a href="#">ngs_10[0]</a> ↓	0xC3	param_10
0x5E: 0x15	<a href="#">step_cou</a> <a href="#">nter.setti</a> <a href="#">ngs_9[1]</a>	0x09	param_9
0x5E: 0x14	<a href="#">step_cou</a> <a href="#">nter.setti</a> <a href="#">ngs_9[0]</a>	0x85	param_9
0x5E: 0x13	<a href="#">step_cou</a> <a href="#">nter.setti</a> <a href="#">ngs_8[1]</a>	0x04	param_8



0x5E: 0x12	<a href="#">step_cou</a> <a href="#">nter.setti</a> <a href="#">ngs_8[0]</a>	0xC3	param_8
0x5E: 0x11	<a href="#">step_cou</a> <a href="#">nter.setti</a> <a href="#">ngs_7[1]</a>	0x6C	param_7
0x5E: 0x10	<a href="#">step_cou</a> <a href="#">nter.setti</a> <a href="#">ngs_7[0]</a>	0xCD	param_7
0x5E: 0x0F	<a href="#">step_cou</a> <a href="#">nter.setti</a> <a href="#">ngs_6[1]</a>	0x7B	param_6
0x5E: 0x0E	<a href="#">step_cou</a> <a href="#">nter.setti</a> <a href="#">ngs_6[0]</a>	0x3F	param_6
0x5E: 0x0D	<a href="#">step_cou</a> <a href="#">nter.setti</a> <a href="#">ngs_5[1]</a>	0x00	param_5
0x5E: 0x0C	<a href="#">step_cou</a> <a href="#">nter.setti</a> <a href="#">ngs_5[0]</a>	0x04	param_5
0x5E: 0x0B	<a href="#">step_cou</a> <a href="#">nter.setti</a> <a href="#">ngs_4[1]</a>	0x7A	param_4
0x5E: 0x0A	<a href="#">step_cou</a> <a href="#">nter.setti</a> <a href="#">ngs_4[0]</a>	0xDB	param_4
0x5E: 0x09	<a href="#">step_cou</a> <a href="#">nter.setti</a> <a href="#">ngs_3[1]</a>	0x01	param_3
0x5E: 0x08	<a href="#">step_cou</a> <a href="#">nter.setti</a> <a href="#">ngs_3[0]</a>	0x3B	param_3
0x5E: 0x07	<a href="#">step_cou</a> <a href="#">nter.setti</a> <a href="#">ngs_2[1]</a>	0x7B	param_2
0x5E: 0x06	<a href="#">step_cou</a> <a href="#">nter.setti</a> <a href="#">ngs_2[0]</a>	0xD4	param_2
0x5E: 0x05	<a href="#">step_cou</a> <a href="#">nter.setti</a> <a href="#">ngs_1[1]</a>	0x01	param_1
0x5E: 0x04	<a href="#">step_cou</a> <a href="#">nter.setti</a> <a href="#">ngs_1[0]</a>	0x2D	param_1



0x5E: 0x03	<a href="#">any moti on.settin gs_2[1]</a>	0x00	z_en	y_en	x_en	duration	
0x5E: 0x02	<a href="#">any moti on.settin gs_2[0]</a>	0x05	duration				
0x5E: 0x01	<a href="#">any moti on.settin gs_1[1]</a>	0x00	reserved			nomotion _sel	threshold
0x5E: 0x00	<a href="#">any moti on.settin gs_1[0]</a>	0xAA	threshold				

**Register (0x00) CHIP\_ID**

DESCRIPTION: Chip identification code

RESET: 0x13

 DEFINITION (Go to [register map](#)):

Name	Register (0x00) CHIP_ID			
Bit	7	6	5	4
Read/Write	R	R	R	R
Reset Value	0	0	0	1
Content	chip_id			
Bit	3	2	1	0
Read/Write	R	R	R	R
Reset Value	0	0	1	1
Content	chip_id			

chip\_id: Chip identification code for BMA425.

**Register (0x02) ERR\_REG**

DESCRIPTION: Reports sensor error conditions

RESET: 0x00

 DEFINITION (Go to [register map](#)):

Name	Register (0x02) ERR_REG			
Bit	7	6	5	4
Read/Write	R	R	n/a	R
Reset Value	0	0	0	0
Content	aux_err	fifo_err	reserved	error_code
Bit	3	2	1	0
Read/Write	R	R	R	R
Reset Value	0	0	0	0
Content	error_code		cmd_err	fatal_err

fatal\_err: Fatal Error, chip is not in operational state (Boot-, power-system). This flag will be reset only by power-on-reset or softreset.

cmd\_err: Command execution failed.

error\_code: Error codes for persistent errors

error_code		
0x00	no_error	no error is reported
0x01	acc_err	error in Register ACC_CONF

fifo\_err: Error in FIFO detected: Input data was discarded in stream mode. This flag will be reset when read.

aux\_err: Error in I2C-Master detected. This flag will be reset when read.

**Register (0x03) STATUS**

DESCRIPTION: Sensor status flags

RESET: 0x10

 DEFINITION (Go to [register map](#)):

Register (0x03) STATUS				
Bit	7	6	5	4
Read/Write	R	n/a	R	R
Reset Value	0	0	0	1
Content	drdy_acc	reserved	drdy_aux	cmd_rdy
Bit	3	2	1	0
Read/Write	n/a	R	n/a	n/a
Reset Value	0	0	0	0
Content	reserved	aux_man_op	reserved	

aux\_man\_op: '1'('0') indicate a (no) manual auxiliary interface operation is ongoing.

cmd\_rdy: CMD decoder status. '0' -&gt; Command in progress '1' -&gt; Command decoder is ready to accept a new command

drdy\_aux: Data ready for auxiliary sensor. It gets reset when one auxiliary DATA register is read out

drdy\_acc: Data ready for accelerometer. It gets reset when one accelerometer DATA register is read out

**Register (0x0A) DATA\_0**

DESCRIPTION: AUX\_X(LSB)

RESET: 0x00

 DEFINITION (Go to [register map](#)):

Register (0x0A) DATA_0				
Bit	7	6	5	4
Read/Write	R	R	R	R
Reset Value	0	0	0	0
Content	aux_x_3_0			
Bit	3	2	1	0
Read/Write	n/a	n/a	n/a	n/a
Reset Value	0	0	0	0
Content	reserved			

**Register (0x0B) DATA\_1**

DESCRIPTION: AUX\_X(MSB)

RESET: 0x00

DEFINITION (Go to [register map](#)):

Name	Register (0x0B) DATA_1			
Bit	7	6	5	4
Read/Write	R	R	R	R
Reset Value	0	0	0	0
Content	aux_x_11_4			
Bit	3	2	1	0
Read/Write	R	R	R	R
Reset Value	0	0	0	0
Content	aux_x_11_4			

**Register (0x0C) DATA\_2**

DESCRIPTION: AUX\_Y(LSB)

RESET: 0x00

DEFINITION (Go to [register map](#)):

Name	Register (0x0C) DATA_2			
Bit	7	6	5	4
Read/Write	R	R	R	R
Reset Value	0	0	0	0
Content	aux_y_3_0			
Bit	3	2	1	0
Read/Write	n/a	n/a	n/a	n/a
Reset Value	0	0	0	0
Content	reserved			

**Register (0x0D) DATA\_3**

DESCRIPTION: AUX\_Y(MSB)

RESET: 0x00

DEFINITION (Go to [register map](#)):

Name	Register (0x0D) DATA_3			
Bit	7	6	5	4
Read/Write	R	R	R	R
Reset Value	0	0	0	0
Content	aux_y_11_4			
Bit	3	2	1	0
Read/Write	R	R	R	R
Reset Value	0	0	0	0
Content	aux_y_11_4			

**Register (0x0E) DATA\_4**

DESCRIPTION: AUX\_Z(LSB)

RESET: 0x00

DEFINITION (Go to [register map](#)):

Name	Register (0x0E) DATA_4			
Bit	7	6	5	4
Read/Write	R	R	R	R
Reset Value	0	0	0	0
Content	aux_z_3_0			
Bit	3	2	1	0
Read/Write	n/a	n/a	n/a	n/a
Reset Value	0	0	0	0
Content	reserved			



**Register (0x0F) DATA\_5**

DESCRIPTION: AUX\_Z(MSB)

RESET: 0x00

DEFINITION (Go to [register map](#)):

Name	Register (0x0F) DATA_5			
Bit	7	6	5	4
Read/Write	R	R	R	R
Reset Value	0	0	0	0
Content	aux_z_11_4			
Bit	3	2	1	0
Read/Write	R	R	R	R
Reset Value	0	0	0	0
Content	aux_z_11_4			

**Register (0x10) DATA\_6**

DESCRIPTION: AUX\_R(LSB)

RESET: 0x00

DEFINITION (Go to [register map](#)):

Name	Register (0x10) DATA_6			
Bit	7	6	5	4
Read/Write	R	R	R	R
Reset Value	0	0	0	0
Content	aux_r_3_0			
Bit	3	2	1	0
Read/Write	n/a	n/a	n/a	n/a
Reset Value	0	0	0	0
Content	reserved			

**Register (0x11) DATA\_7**

DESCRIPTION: AUX\_R(MSB)

RESET: 0x00

 DEFINITION (Go to [register map](#)):

Name	Register (0x11) DATA_7			
Bit	7	6	5	4
Read/Write	R	R	R	R
Reset Value	0	0	0	0
Content	aux_r_11_4			
Bit	3	2	1	0
Read/Write	R	R	R	R
Reset Value	0	0	0	0
Content	aux_r_11_4			

**Register (0x12) DATA\_8**

DESCRIPTION: ACC\_X(LSB)

RESET: 0x00

 DEFINITION (Go to [register map](#)):

Name	Register (0x12) DATA_8			
Bit	7	6	5	4
Read/Write	R	R	R	R
Reset Value	0	0	0	0
Content	acc_x_3_0			
Bit	3	2	1	0
Read/Write	n/a	n/a	n/a	n/a
Reset Value	0	0	0	0
Content	reserved			

**Register (0x13) DATA\_9**

DESCRIPTION: ACC\_X(MSB)

RESET: 0x00

 DEFINITION (Go to [register map](#)):

Name	Register (0x13) DATA_9			
Bit	7	6	5	4
Read/Write	R	R	R	R
Reset Value	0	0	0	0
Content	acc_x_11_4			
Bit	3	2	1	0
Read/Write	R	R	R	R
Reset Value	0	0	0	0
Content	acc_x_11_4			

**Register (0x14) DATA\_10**

DESCRIPTION: ACC\_Y(LSB)

RESET: 0x00

 DEFINITION (Go to [register map](#)):

Name	Register (0x14) DATA_10			
Bit	7	6	5	4
Read/Write	R	R	R	R
Reset Value	0	0	0	0
Content	acc_y_3_0			
Bit	3	2	1	0
Read/Write	n/a	n/a	n/a	n/a
Reset Value	0	0	0	0
Content	reserved			

**Register (0x15) DATA\_11**

DESCRIPTION: ACC\_Y(MSB)

RESET: 0x00

DEFINITION (Go to [register map](#)):

Name	Register (0x15) DATA_11			
Bit	7	6	5	4
Read/Write	R	R	R	R
Reset Value	0	0	0	0
Content	acc_y_11_4			
Bit	3	2	1	0
Read/Write	R	R	R	R
Reset Value	0	0	0	0
Content	acc_y_11_4			

**Register (0x16) DATA\_12**

DESCRIPTION: ACC\_Z(LSB)

RESET: 0x00

DEFINITION (Go to [register map](#)):

Name	Register (0x16) DATA_12			
Bit	7	6	5	4
Read/Write	R	R	R	R
Reset Value	0	0	0	0
Content	acc_z_3_0			
Bit	3	2	1	0
Read/Write	n/a	n/a	n/a	n/a
Reset Value	0	0	0	0
Content	reserved			

**Register (0x17) DATA\_13**

DESCRIPTION: ACC\_Z(MSB)

RESET: 0x00

DEFINITION (Go to [register map](#)):

Name	Register (0x17) DATA_13			
Bit	7	6	5	4
Read/Write	R	R	R	R
Reset Value	0	0	0	0
Content	acc_z_11_4			
Bit	3	2	1	0
Read/Write	R	R	R	R
Reset Value	0	0	0	0
Content	acc_z_11_4			

**Register (0x18) SENSORTIME\_0**

DESCRIPTION: Sensor time &lt;7:0&gt;

RESET: 0x00

DEFINITION (Go to [register map](#)):

Name	Register (0x18) SENSORTIME_0			
Bit	7	6	5	4
Read/Write	R	R	R	R
Reset Value	0	0	0	0
Content	sensor_time_7_0			
Bit	3	2	1	0
Read/Write	R	R	R	R
Reset Value	0	0	0	0
Content	sensor_time_7_0			

sensor\_time\_7\_0: Sensor time &lt;7:0&gt; in units of 39.0625 us.

**Register (0x19) SENSORTIME\_1**

DESCRIPTION: Sensor time &lt;15:8&gt;

RESET: 0x00

 DEFINITION (Go to [register map](#)):

Register (0x19) SENSORTIME_1				
Bit	7	6	5	4
Read/Write	R	R	R	R
Reset Value	0	0	0	0
Content	sensor_time_15_8			
Bit	3	2	1	0
Read/Write	R	R	R	R
Reset Value	0	0	0	0
Content	sensor_time_15_8			

sensor\_time\_15\_8: Sensor time &lt;15:8&gt; in units of 10 ms.

**Register (0x1A) SENSORTIME\_2**

DESCRIPTION: Sensor time &lt;23:16&gt;

RESET: 0x00

 DEFINITION (Go to [register map](#)):

Register (0x1A) SENSORTIME_2				
Bit	7	6	5	4
Read/Write	R	R	R	R
Reset Value	0	0	0	0
Content	sensor_time_23_16			
Bit	3	2	1	0
Read/Write	R	R	R	R
Reset Value	0	0	0	0
Content	sensor_time_23_16			

sensor\_time\_23\_16: Sensor time &lt;23:16&gt; in units of 2.56 s.

**Register (0x1B) EVENT**

DESCRIPTION: Sensor status flags

RESET: 0x01

 DEFINITION (Go to [register map](#)):

Name	Register (0x1B) EVENT			
Bit	7	6	5	4
Read/Write	n/a	n/a	n/a	n/a
Reset Value	0	0	0	0
Content	reserved			
Bit	3	2	1	0
Read/Write	n/a	n/a	n/a	R
Reset Value	0	0	0	1
Content	reserved			por_detected

por\_detected: '1' after device power up or softreset. Clear-on-read

**Register (0x1C) INT\_STATUS\_0**

DESCRIPTION: Interrupt/Feature Status. Will be cleared on read.

RESET: 0x00

 DEFINITION (Go to [register map](#)):

Name	Register (0x1C) INT_STATUS_0			
Bit	7	6	5	4
Read/Write	R	R	R	n/a
Reset Value	0	0	0	0
Content	error_int_out	any_no_motion_out	wakeup_out	reserved
Bit	3	2	1	0
Read/Write	R	R	R	n/a
Reset Value	0	0	0	0
Content	wrist_tilt_out	activity_type_out	step_counter_out	reserved

step\_counter\_out: Step-counter watermark or Step-detector output.

activity\_type\_out: Step counter activity output(Running, Walking, Still)

wrist\_tilt\_out: Wrist tilt output

wakeup\_out: Wakeup output

any\_no\_motion\_out: Any-motion/No-motion detection output

error\_int\_out: Error interrupt output

**Register (0x1D) INT\_STATUS\_1**

DESCRIPTION: Interrupt Status. Will be cleared on read.

RESET: 0x00

 DEFINITION (Go to [register map](#)):

Name	Register (0x1D) INT_STATUS_1			
Bit	7	6	5	4
Read/Write	R	n/a	R	n/a
Reset Value	0	0	0	0
Content	acc_drdy_int	reserved	aux_drdy_int	reserved
Bit	3	2	1	0
Read/Write	n/a	n/a	R	R
Reset Value	0	0	0	0
Content	reserved		fwm_int	ffull_int

ffull\_int: FIFO Full Interrupt

fwm\_int: FIFO Watermark Interrupt

aux\_drdy\_int: Auxiliary sensor data ready interrupt

acc\_drdy\_int: Accelerometer data ready interrupt

**Register (0x1E) STEP\_COUNTER\_0**

DESCRIPTION: Step counting value byte-0

RESET: 0x00

 DEFINITION (Go to [register map](#)):

Name	Register (0x1E) STEP_COUNTER_0			
Bit	7	6	5	4
Read/Write	R	R	R	R
Reset Value	0	0	0	0
Content	step_counter_out_0			
Bit	3	2	1	0
Read/Write	R	R	R	R
Reset Value	0	0	0	0
Content	step_counter_out_0			

step\_counter\_out\_0: Step counting value byte-0 (least significant byte)



**Register (0x1F) STEP\_COUNTER\_1**

DESCRIPTION: Step counting value byte-1

RESET: 0x00

DEFINITION (Go to [register map](#)):

Name	Register (0x1F) STEP_COUNTER_1			
Bit	7	6	5	4
Read/Write	R	R	R	R
Reset Value	0	0	0	0
Content	step_counter_out_1			
Bit	3	2	1	0
Read/Write	R	R	R	R
Reset Value	0	0	0	0
Content	step_counter_out_1			

step\_counter\_out\_1: Step counting value byte-1

**Register (0x20) STEP\_COUNTER\_2**

DESCRIPTION: Step counting value byte-2

RESET: 0x00

DEFINITION (Go to [register map](#)):

Name	Register (0x20) STEP_COUNTER_2			
Bit	7	6	5	4
Read/Write	R	R	R	R
Reset Value	0	0	0	0
Content	step_counter_out_2			
Bit	3	2	1	0
Read/Write	R	R	R	R
Reset Value	0	0	0	0
Content	step_counter_out_2			

step\_counter\_out\_2: Step counting value byte-2

**Register (0x21) STEP\_COUNTER\_3**

DESCRIPTION: Step counting value byte-3

RESET: 0x00

 DEFINITION (Go to [register map](#)):

Name	Register (0x21) STEP_COUNTER_3			
Bit	7	6	5	4
Read/Write	R	R	R	R
Reset Value	0	0	0	0
Content	step_counter_out_3			
Bit	3	2	1	0
Read/Write	R	R	R	R
Reset Value	0	0	0	0
Content	step_counter_out_3			

step\_counter\_out\_3: Step counting value byte-3 (most significant byte)

**Register (0x22) TEMPERATURE**

DESCRIPTION: Contains the temperature value of the sensor

RESET: 0x00

 DEFINITION (Go to [register map](#)):

Name	Register (0x22) TEMPERATURE			
Bit	7	6	5	4
Read/Write	R	R	R	R
Reset Value	0	0	0	0
Content	temperature			
Bit	3	2	1	0
Read/Write	R	R	R	R
Reset Value	0	0	0	0
Content	temperature			

temperature: Temperature value in two's complement representation in units of 1 Kelvin: 0x00 corresponds to 23 degree Celsius.

**Register (0x24) FIFO\_LENGTH\_0**

DESCRIPTION: FIFO byte count register (LSB)

RESET: 0x00

DEFINITION (Go to [register map](#)):

Name	Register (0x24) FIFO_LENGTH_0			
Bit	7	6	5	4
Read/Write	R	R	R	R
Reset Value	0	0	0	0
Content	fifo_byte_counter_7_0			
Bit	3	2	1	0
Read/Write	R	R	R	R
Reset Value	0	0	0	0
Content	fifo_byte_counter_7_0			

fifo\_byte\_counter\_7\_0: Current fill level of FIFO buffer.

**Register (0x25) FIFO\_LENGTH\_1**

DESCRIPTION: FIFO byte count register (MSB)

RESET: 0x00

DEFINITION (Go to [register map](#)):

Name	Register (0x25) FIFO_LENGTH_1			
Bit	7	6	5	4
Read/Write	n/a	n/a	R	R
Reset Value	0	0	0	0
Content	reserved		fifo_byte_counter_13_8	
Bit	3	2	1	0
Read/Write	R	R	R	R
Reset Value	0	0	0	0
Content	fifo_byte_counter_13_8			

fifo\_byte\_counter\_13\_8: FIFO byte counter bits 13..8

**Register (0x26) FIFO\_DATA**

DESCRIPTION: FIFO data output register

RESET: 0x00

 DEFINITION (Go to [register map](#)):

Name	Register (0x26) FIFO_DATA			
Bit	7	6	5	4
Read/Write	R	R	R	R
Reset Value	0	0	0	0
Content	fifo_data			
Bit	3	2	1	0
Read/Write	R	R	R	R
Reset Value	0	0	0	0
Content	fifo_data			

fifo\_data: FIFO read data.

**Register (0x27) ACTIVITY\_TYPE**

DESCRIPTION: Step counter activity output(Running, Walking, Still)

RESET: 0x00

 DEFINITION (Go to [register map](#)):

Name	Register (0x27) ACTIVITY_TYPE			
Bit	7	6	5	4
Read/Write	n/a	n/a	n/a	n/a
Reset Value	0	0	0	0
Content	reserved			
Bit	3	2	1	0
Read/Write	n/a	n/a	R	R
Reset Value	0	0	0	0
Content	reserved		activity_type_out	

activity\_type\_out: Step counter activity output(Running, Walking, Still)

activity_type_out		
0x00	still	user not moving
0x01	walking	user walking
0x02	running	user running
0x03	unknown	unknown state

**Register (0x2A) INTERNAL\_STATUS**

DESCRIPTION: Error bits and message indicating internal status

RESET: 0x00

 DEFINITION (Go to [register map](#)):

Register (0x2A) INTERNAL_STATUS				
Bit	7	6	5	4
Read/Write	R	R	R	R
Reset Value	0	0	0	0
Content	odr_high_error	odr_50hz_error	axes_remap_error	message
Bit	3	2	1	0
Read/Write	R	R	R	R
Reset Value	0	0	0	0
Content	message			

message: Internal Status Message

message		
0x00	not_init	ASIC is not initialized
0x01	init_ok	ASIC initialized
0x02	init_err	Initialization error
0x03	drv_err	Invalid driver
0x04	sns_stop	Sensor stopped

axes\_remap\_error: Axes remapped wrongly because a source axis is not assigned to more than one target axis.

odr\_50hz\_error: The minimum bandwidth conditions are not respected for the features which require 50 Hz data.

odr\_high\_error: The minimum bandwidth conditions are not respected for the Wakeup Detection.

**Register (0x40) ACC\_CONF**

DESCRIPTION: Sets the output data rate, the bandwidth, and the read mode of the acceleration sensor

RESET: 0xA8

DEFINITION (Go to [register map](#)):

Name	Register (0x40) ACC_CONF			
Bit	7	6	5	4
Read/Write	RW	RW	RW	RW
Reset Value	1	0	1	0
Content	acc_perf_mode		acc_bwp	
Bit	3	2	1	0
Read/Write	RW	RW	RW	RW
Reset Value	1	0	0	0
Content	acc_odr			

acc\_odr: ODR in Hz. The output data rate is independent of the power mode setting for the sensor, but not all settings are supported in all power modes.

acc_odr		
0x00	reserved	Reserved
0x01	odr_0p78	25/32
0x02	odr_1p5	25/16
0x03	odr_3p1	25/8
0x04	odr_6p25	25/4
0x05	odr_12p5	25/2
0x06	odr_25	25
0x07	odr_50	50
0x08	odr_100	100
0x09	odr_200	200
0x0a	odr_400	400
0x0b	odr_800	800
0x0c	odr_1k6	1600
0x0d	odr_3k2	Reserved
0x0e	odr_6k4	Reserved
0x0f	odr_12k8	Reserved

acc\_bwp: Bandwidth parameter, determines filter configuration (acc\_perf\_mode=1) and averaging for undersampling mode (acc\_perf\_mode=0)

acc_bwp		
0x00	osr4_avg1	acc_perf_mode = 1 -> OSR4 mode; acc_perf_mode = 0 -> no averaging
0x01	osr2_avg2	acc_perf_mode = 1 -> OSR2 mode; acc_perf_mode = 0 -> average 2 samples
0x02	norm_avg4	acc_perf_mode = 1 -> normal mode; acc_perf_mode = 0 -> average 4 samples
0x03	cic_avg8	acc_perf_mode = 1 -> Reserved; acc_perf_mode = 0 -> average 8 samples
0x04	res_avg16	acc_perf_mode = 1 -> Reserved; acc_perf_mode = 0 -> average 16 samples
0x05	res_avg32	acc_perf_mode = 1 -> Reserved; acc_perf_mode = 0 -> average 32 samples
0x06	res_avg64	acc_perf_mode = 1 -> Reserved; acc_perf_mode = 0 -> average 64 samples
0x07	res_avg128	acc_perf_mode = 1 -> Reserved; acc_perf_mode = 0 -> average 128 samples

acc\_perf\_mode: Select accelerometer filter performance mode:

acc_perf_mode		
0x00	cic_avg	averaging mode.
0x01	cont	continuous filter function.

### Register (0x41) ACC\_RANGE

DESCRIPTION: Selection of the Accelerometer g-range

RESET: 0x01

DEFINITION (Go to [register map](#)):

Name	Register (0x41) ACC_RANGE			
Bit	7	6	5	4
Read/Write	n/a	n/a	n/a	n/a
Reset Value	0	0	0	0
Content	reserved			
Bit	3	2	1	0
Read/Write	n/a	n/a	RW	RW
Reset Value	0	0	0	1
Content	reserved		acc_range	

acc\_range: Accelerometer g-range

acc_range		
0x00	range_2g	+/-2g
0x01	range_4g	+/-4g
0x02	range_8g	+/-8g
0x03	range_16g	+/-16g

### Register (0x44) AUX\_CONF

DESCRIPTION: Sets the output data rate of the Auxiliary interface

RESET: 0x46

 DEFINITION (Go to [register map](#)):

Name	Register (0x44) AUX_CONF			
Bit	7	6	5	4
Read/Write	RW	RW	RW	RW
Reset Value	0	1	0	0
Content	aux_offset			
Bit	3	2	1	0
Read/Write	RW	RW	RW	RW
Reset Value	0	1	1	0
Content	aux_odr			

aux\_odr: Select the poll rate for the sensor attached to the Auxiliary interface.

aux_odr		
0x00	reserved	Reserved
0x01	odr_0p78	25/32
0x02	odr_1p5	25/16
0x03	odr_3p1	25/8
0x04	odr_6p25	25/4
0x05	odr_12p5	25/2
0x06	odr_25	25
0x07	odr_50	50
0x08	odr_100	100
0x09	odr_200	200
0x0a	odr_400	400
0x0b	odr_800	800
0x0c	odr_1k6	Reserved
0x0d	odr_3k2	Reserved
0x0e	odr_6k4	Reserved
0x0f	odr_12k8	Reserved



aux\_offset: trigger-readout offset in units of 2.5 ms. If set to zero, the offset is maximum, i.e. after readout a trigger is issued immediately.

### Register (0x45) FIFO\_DOWNS

DESCRIPTION: Configure Accelerometer downsampling rates for FIFO

RESET: 0x80

DEFINITION (Go to [register map](#)):

Name	Register (0x45) FIFO_DOWNS			
Bit	7	6	5	4
Read/Write	RW	RW	RW	RW
Reset Value	1	0	0	0
Content	acc_fifo_filt_data acc_fifo_downs			
Bit	3	2	1	0
Read/Write	n/a	n/a	n/a	n/a
Reset Value	0	0	0	0
Content	reserved			

acc\_fifo\_downs: Downsampling for accelerometer data ( $2^{**}acc\_fifo\_downs$ )

acc\_fifo\_filt\_data: selects filtered or unfiltered Accelerometer data for fifo

acc_fifo_filt_data		
0x00	unfiltered	Unfiltered data
0x01	filtered	Filtered data

### Register (0x46) FIFO\_WTM\_0

DESCRIPTION: FIFO Watermark level LSB

RESET: 0x00

DEFINITION (Go to [register map](#)):

Name	Register (0x46) FIFO_WTM_0			
Bit	7	6	5	4
Read/Write	RW	RW	RW	RW
Reset Value	0	0	0	0
Content	fifo_water_mark_7_0			
Bit	3	2	1	0
Read/Write	RW	RW	RW	RW
Reset Value	0	0	0	0
Content	fifo_water_mark_7_0			

**Register (0x47) FIFO\_WTM\_1**

DESCRIPTION: FIFO Watermark level MSB

RESET: 0x02

 DEFINITION (Go to [register map](#)):

Name	Register (0x47) FIFO_WTM_1			
Bit	7	6	5	4
Read/Write	n/a	n/a	n/a	RW
Reset Value	0	0	0	0
Content	reserved			fifo_water_mark_12_8
Bit	3	2	1	0
Read/Write	RW	RW	RW	RW
Reset Value	0	0	1	0
Content	fifo_water_mark_12_8			

**Register (0x48) FIFO\_CONFIG\_0**

DESCRIPTION: FIFO frame content configuration

RESET: 0x02

 DEFINITION (Go to [register map](#)):

Name	Register (0x48) FIFO_CONFIG_0			
Bit	7	6	5	4
Read/Write	n/a	n/a	n/a	n/a
Reset Value	0	0	0	0
Content	reserved			
Bit	3	2	1	0
Read/Write	n/a	n/a	RW	RW
Reset Value	0	0	1	0
Content	reserved		fifo_time_en	fifo_stop_on_full

fifo\_stop\_on\_full: Stop writing samples into FIFO when FIFO is full.

fifo_stop_on_full		
0x00	disable	do not stop writing to FIFO when full
0x01	enable	Stop writing into FIFO when full.

fifo\_time\_en: Return sensortime frame after the last valid data frame.

fifo_time_en		
0x00	disable	do not return sensortime frame
0x01	enable	return sensortime frame

**Register (0x49) FIFO\_CONFIG\_1**

DESCRIPTION: FIFO frame content configuration

RESET: 0x10

DEFINITION (Go to [register map](#)):

Register (0x49) FIFO_CONFIG_1				
Bit	7	6	5	4
Read/Write	n/a	RW	RW	RW
Reset Value	0	0	0	1
Content	reserved	fifo_acc_en	fifo_aux_en	fifo_header_en
Bit	3	2	1	0
Read/Write	RW	RW	n/a	n/a
Reset Value	0	0	0	0
Content	fifo_tag_int1_en	fifo_tag_int2_en	reserved	

fifo\_tag\_int2\_en: FIFO interrupt 2 tag enable

fifo_tag_int2_en		
0x00	disable	disable tag
0x01	enable	enable tag

fifo\_tag\_int1\_en: FIFO interrupt 1 tag enable

fifo_tag_int1_en		
0x00	disable	disable tag
0x01	enable	enable tag

fifo\_header\_en: FIFO frame header enable

fifo_header_en		
0x00	disable	no header is stored (output data rate of all enabled sensors need to be identical)
0x01	enable	header is stored

fifo\_aux\_en: Store Auxiliary data in FIFO (all 3 axes)

fifo_aux_en		
0x00	disable	no Auxiliary data is stored
0x01	enable	Auxiliary data is stored

fifo\_acc\_en: Store Accelerometer data in FIFO (all 3 axes)

fifo_acc_en		
0x00	disable	no Accelerometer data is stored
0x01	enable	Accelerometer data is stored

**Register (0x4B) AUX\_DEV\_ID**

DESCRIPTION: Auxiliary interface slave device id

RESET: 0x20

 DEFINITION (Go to [register map](#)):

Register (0x4B) AUX_DEV_ID				
Bit	7	6	5	4
Read/Write	RW	RW	RW	RW
Reset Value	0	0	1	0
Content	i2c_device_addr			
Bit	3	2	1	0
Read/Write	RW	RW	RW	n/a
Reset Value	0	0	0	0
Content	i2c_device_addr			reserved

i2c\_device\_addr: I2C device address of Auxiliary slave

**Register (0x4C) AUX\_IF\_CONF**

DESCRIPTION: Auxiliary interface configuration

RESET: 0x83

 DEFINITION (Go to [register map](#)):

Register (0x4C) AUX_IF_CONF				
Bit	7	6	5	4
Read/Write	RW	n/a	n/a	n/a
Reset Value	1	0	0	0
Content	aux_manual_en	reserved		
Bit	3	2	1	0
Read/Write	n/a	n/a	RW	RW
Reset Value	0	0	1	1
Content	reserved		aux_rd_burst	

aux\_rd\_burst: Burst data length (1,2,6,8 byte)

aux_rd_burst		
0x00	BL1	Burst length 1
0x01	BL2	Burst length 2
0x02	BL6	Burst length 6
0x03	BL8	Burst length 8

aux\_manual\_en: Enable auxiliary interface manual mode.

aux_manual_en		
0x00	disable	Data mode
0x01	enable	Setup mode

**Register (0x4D) AUX\_RD\_ADDR**

DESCRIPTION: Auxiliary interface read register address

RESET: 0x42

DEFINITION (Go to [register map](#)):

Name	Register (0x4D) AUX_RD_ADDR			
Bit	7	6	5	4
Read/Write	RW	RW	RW	RW
Reset Value	0	1	0	0
Content	read_addr			
Bit	3	2	1	0
Read/Write	RW	RW	RW	RW
Reset Value	0	0	1	0
Content	read_addr			

read\_addr: Address to read

**Register (0x4E) AUX\_WR\_ADDR**

DESCRIPTION: Auxiliary interface write register address

RESET: 0x4C

DEFINITION (Go to [register map](#)):

Name	Register (0x4E) AUX_WR_ADDR			
Bit	7	6	5	4
Read/Write	RW	RW	RW	RW
Reset Value	0	1	0	0
Content	write_addr			
Bit	3	2	1	0
Read/Write	RW	RW	RW	RW
Reset Value	1	1	0	0
Content	write_addr			

write\_addr: Address to write

**Register (0x4F) AUX\_WR\_DATA**

DESCRIPTION: Auxiliary interface write data

RESET: 0x02

 DEFINITION (Go to [register map](#)):

Register (0x4F) AUX_WR_DATA				
Bit	7	6	5	4
Read/Write	RW	RW	RW	RW
Reset Value	0	0	0	0
Content	write_data			
Bit	3	2	1	0
Read/Write	RW	RW	RW	RW
Reset Value	0	0	1	0
Content	write_data			

write\_data: Data to write

**Register (0x53) INT1\_IO\_CTRL**

DESCRIPTION: Configure the electrical behaviour of the interrupt pins

RESET: 0x00

 DEFINITION (Go to [register map](#)):

Register (0x53) INT1_IO_CTRL				
Bit	7	6	5	4
Read/Write	n/a	n/a	n/a	RW
Reset Value	0	0	0	0
Content	reserved			input_en
Bit	3	2	1	0
Read/Write	RW	RW	RW	RW
Reset Value	0	0	0	0
Content	output_en	od	lvl	edge_ctrl

edge\_ctrl: Configure trigger condition of INT1 pin (input)

edge_ctrl		
0x00	level_tr	Level
0x01	edge_tr	Edge

lvl: Configure level of INT1 pin

lvl		
0x00	active_low	active low
0x01	active_high	active high

od: Configure behaviour of INT1 pin to open drain.

od		
0x00	push_pull	push-pull
0x01	open_drain	open drain

output\_en: Output enable for INT1 pin

output_en		
0x00	off	Output disabled
0x01	on	Output enabled

input\_en: Input enable for INT1 pin

input_en		
0x00	off	Input disabled
0x01	on	Input enabled

### Register (0x54) INT2\_IO\_CTRL

DESCRIPTION: Configure the electrical behaviour of the interrupt pins

RESET: 0x00

DEFINITION (Go to [register map](#)):

Name	Register (0x54) INT2_IO_CTRL			
Bit	7	6	5	4
Read/Write	n/a	n/a	n/a	RW
Reset Value	0	0	0	0
Content	reserved			input_en
Bit	3	2	1	0
Read/Write	RW	RW	RW	RW
Reset Value	0	0	0	0
Content	output_en	od	lvl	edge_ctrl

edge\_ctrl: Configure trigger condition of INT2 pin (input)

edge_ctrl		
0x00	level_tr	Level
0x01	edge_tr	Edge

lvl: Configure level of INT2 pin

lvl		
0x00	active_low	active low
0x01	active_high	active high

od: Configure behaviour of INT2 pin to open drain.

od		
0x00	push_pull	push-pull
0x01	open_drain	open drain

output\_en: Output enable for INT2 pin

output_en		
0x00	off	Output disabled
0x01	on	Output enabled

input\_en: Input enable for INT2 pin

input_en		
0x00	off	Input disabled
0x01	on	Input enabled

### Register (0x55) INT\_LATCH

DESCRIPTION: Configure interrupt modes

RESET: 0x00

DEFINITION (Go to [register map](#)):

Name	Register (0x55) INT_LATCH			
Bit	7	6	5	4
Read/Write	n/a	n/a	n/a	n/a
Reset Value	0	0	0	0
Content	reserved			
Bit	3	2	1	0
Read/Write	n/a	n/a	n/a	RW
Reset Value	0	0	0	0
Content	reserved			int_latch

int\_latch: Latched/non-latched/temporary interrupt modes

int_latch		
0x00	none	non latched
0x01	permanent	latched



**Register (0x56) INT1\_MAP**

DESCRIPTION: Interrupt/Feature mapping on INT1

RESET: 0x00

DEFINITION (Go to [register map](#)):

Name	Register (0x56) INT1_MAP			
Bit	7	6	5	4
Read/Write	RW	RW	RW	n/a
Reset Value	0	0	0	0
Content	error_int_out	any_no_motion_out	wakeup_out	reserved
Bit	3	2	1	0
Read/Write	RW	RW	RW	n/a
Reset Value	0	0	0	0
Content	wrist_tilt_out	activity_type_out	step_counter_out	reserved

step\_counter\_out: Step-counter watermark or Step-detector output.

activity\_type\_out: Step counter activity output(Running, Walking, Still)

wrist\_tilt\_out: Wrist tilt output

wakeup\_out: Wakeup output

any\_no\_motion\_out: Any-motion/No-motion detection output

error\_int\_out: Error interrupt output

**Register (0x57) INT2\_MAP**

DESCRIPTION: Interrupt/Feature mapping on INT2

RESET: 0x00

DEFINITION (Go to [register map](#)):

Name	Register (0x57) INT2_MAP			
Bit	7	6	5	4
Read/Write	RW	RW	RW	n/a
Reset Value	0	0	0	0
Content	error_int_out	any_no_motion_out	wakeup_out	reserved
Bit	3	2	1	0
Read/Write	RW	RW	RW	n/a
Reset Value	0	0	0	0
Content	wrist_tilt_out	activity_type_out	step_counter_out	reserved

step\_counter\_out: Step-counter watermark or Step-detector output.

activity\_type\_out: Step counter activity output(Running, Walking, Still)

wrist\_tilt\_out: Wrist tilt output

wakeup\_out: Wakeup output

any\_no\_motion\_out: Any-motion/No-motion detection output

error\_int\_out: Error interrupt output

### Register (0x58) INT\_MAP\_DATA

DESCRIPTION: Interrupt mapping hardware interrupts

RESET: 0x00

DEFINITION (Go to [register map](#)):

Name	Register (0x58) INT_MAP_DATA			
Bit	7	6	5	4
Read/Write	n/a	RW	RW	RW
Reset Value	0	0	0	0
Content	reserved	int2_drdy	int2_fwm	int2_full
Bit	3	2	1	0
Read/Write	n/a	RW	RW	RW
Reset Value	0	0	0	0
Content	reserved	int1_drdy	int1_fwm	int1_full

int1\_full: FIFO Full interrupt mapped to INT1

int1\_fwm: FIFO Watermark interrupt mapped to INT1

int1\_drdy: Data Ready interrupt mapped to INT1

int2\_full: FIFO Full interrupt mapped to INT2

int2\_fwm: FIFO Watermark interrupt mapped to INT2

int2\_drdy: Data Ready interrupt mapped to INT2

### Register (0x59) INIT\_CTRL

DESCRIPTION: Start initialization

RESET: 0x90

DEFINITION (Go to [register map](#)):

Name	Register (0x59) INIT_CTRL			
Bit	7	6	5	4
Read/Write	RW	RW	RW	RW
Reset Value	1	0	0	1
Content	init_ctrl			
Bit	3	2	1	0
Read/Write	RW	RW	RW	RW
Reset Value	0	0	0	0
Content	init_ctrl			

init\_ctrl: Start initialization

**Register (0x5E) FEATURES\_IN**

DESCRIPTION: Feature configuration read/write port

RESET: 0x00

 DEFINITION (Go to [register map](#)):

Name	Register (0x5E) FEATURES_IN			
Bit	7	6	5	4
Read/Write	RW	RW	RW	RW
Reset Value	0	0	0	0
Content	features_in			
Bit	3	2	1	0
Read/Write	RW	RW	RW	RW
Reset Value	0	0	0	0
Content	features_in			

features\_in: Feature configuration read/write data

Address	Bit	Name	Description	Reset	Access
any_motion					
0x5E: 0x00		settings_1	Any-motion / No-motion detection general configuration flags - part 1	0x00AA	
	10...0	threshold	Slope threshold value for Any-motion / No-motion detection in 5.11g format. Range is 0 to 1g. Default value is 0xAA = 83mg.	0xAA	RW
	11	nomotion_sel	Indicates if Nomotion (1) or Any-motion (0) is selected; default value is 0 – Any-motion.	0x0	RW
0x5E: 0x02		settings_2	Any-motion / No-motion detection general configuration flags - part 2	0x0005	
	12...0	duration	Defines the number of consecutive data points for which the threshold condition must be respected, for interrupt assertion. It is expressed in in 50 Hz samples (20 ms). Range is 0 to 163sec. Default value is 5=100ms.	0x5	RW
	13	x_en	Enables the feature on a per-axis basis	0x0	RW
	14	y_en	Enables the feature on a per-axis basis	0x0	RW
	15	z_en	Enables the feature on a per-axis basis	0x0	RW
step_counter					
		settings_1	Step Counter setting	0x012D	

0x5E: 0x04	15...0	param_1	Step Counter param 1	0x12D	RW
0x5E: 0x06		settings_2	Step Counter setting	0x7BD4	
	15...0	param_2	Step Counter param 2	0x7BD4	RW
0x5E: 0x08		settings_3	Step Counter setting	0x013B	
	15...0	param_3	Step Counter param 3	0x13B	RW
0x5E: 0x0A		settings_4	Step Counter setting	0x7ADB	
	15...0	param_4	Step Counter param 4	0x7ADB	RW
0x5E: 0x0C		settings_5	Step Counter setting	0x0004	
	15...0	param_5	Step Counter param 5	0x4	RW
0x5E: 0x0E		settings_6	Step Counter setting	0x7B3F	
	15...0	param_6	Step Counter param 6	0x7B3F	RW
0x5E: 0x10		settings_7	Step Counter setting	0x6CCD	
	15...0	param_7	Step Counter param 7	0x6CCD	RW
0x5E: 0x12		settings_8	Step Counter setting	0x04C3	
	15...0	param_8	Step Counter param 8	0x4C3	RW
0x5E: 0x14		settings_9	Step Counter setting	0x0985	
	15...0	param_9	Step Counter param 9	0x985	RW
0x5E: 0x16		settings_10	Step Counter setting	0x04C3	
	15...0	param_10	Step Counter param 10	0x4C3	RW
0x5E: 0x18		settings_11	Step Counter setting	0xE6EC	
	15...0	param_11	Step Counter param 11	0xE6EC	RW
0x5E: 0x1A		settings_12	Step Counter setting	0x460C	
	15...0	param_12	Step Counter param 12	0x460C	RW
0x5E: 0x1C		settings_13	Step Counter setting	0x0001	
	15...0	param_13	Step Counter param 13	0x1	RW
0x5E: 0x1E		settings_14	Step Counter setting	0x0027	
	15...0	param_14	Step Counter param 14	0x27	RW
0x5E: 0x20		settings_15	Step Counter setting	0x0019	
	15...0	param_15	Step Counter param 15	0x19	RW
0x5E: 0x22		settings_16	Step Counter setting	0x0096	
	15...0	param_16	Step Counter param 16	0x96	RW
0x5E: 0x24		settings_17	Step Counter setting	0x00A0	
	15...0	param_17	Step Counter param 17	0xA0	RW
0x5E: 0x26		settings_18	Step Counter setting	0x0001	
	15...0	param_18	Step Counter param 18	0x1	RW
0x5E: 0x28		settings_19	Step Counter setting	0x000C	
	15...0	param_19	Step Counter param 19	0xC	RW
0x5E: 0x2A		settings_20	Step Counter setting	0x3CF0	
	15...0	param_20	Step Counter param 20	0x3CF0	RW
0x5E: 0x2C		settings_21	Step Counter setting	0x0100	
	15...0	param_21	Step Counter param 21	0x100	RW

0x5E:		settings_22	Step Counter setting	0x0001	
0x2E	15...0	param_22	Step Counter param 22	0x1	RW
0x5E:		settings_23	Step Counter setting	0x0003	
0x30	15...0	param_23	Step Counter param 23	0x3	RW
0x5E:		settings_24	Step Counter setting	0x0001	
0x32	15...0	param_24	Step Counter param 24	0x1	RW
0x5E:		settings_25	Step Counter setting	0x000E	
0x34	15...0	param_25	Step Counter param 25	0xE	RW
0x5E:		settings_26	Step Counter and Step Detector Settings	0x0000	
0x36	9...0	watermark_level	Watermark level; the Step-counter will trigger output every time this number of steps are counted. Holds implicitly a 20x factor, so the range is 0 to 20460, with resolution of 20 steps. If 0, the output is disabled.	0x0	RW
	10	reset_counter	Flag to reset the counted steps. This is only interpreted if the step counter is enabled.	0x0	RW
	11	en_detector	Enables the Step Detector.	0x0	RW
	12	en_counter	Enables the Step Counter.	0x0	RW
	13	en_activity	Enables the activity detection(Running, Walking, Still)	0x0	RW
<b>tap_doubletap</b>					
0x5E:		settings	Tap general configuration flags	0x0006	
0x38	0	enable	Enables the feature	0x0	RW
	3...1	sensitivity	Configures Tap sensitivity, the range goes from 0 (high sensitive) to 7 (low sensitive).	0x3	RW
	4	single_tap_en	Flag for enabling single tap detection (and disabling double tap). By default double tap detection is being enabled.	0x0	RW
<b>wrist_tilt</b>					
0x5E:		settings	Wrist tilt configuration flags	0x0000	
0x3A	0	enable	Enables the feature	0x0	RW
<b>general_settings</b>					
0x5E:		config_id	Describes configuration identification code	0x0000	
0x3C	15...0	identification	Describes configuration identification code	0x0	R

0x5E: 0x3E		<b>axes_remapping</b>	Describes axes remapping	0x0088	
	1...0	map_x_axis	Map the x axis to desired axis. <b>Value Name Description</b> 0x00 x axis Map to x-axis 0x01 y axis Map to y-axis 0x02 z axis Map to z-axis 0x03 reserved reserved	0x0	RW
	2	map_x_axis_sign	Map the x axis sign to the desired one. <b>Value Name Description</b> 0x00 non-inverted Clear this bit to non invert the x axis 0x01 inverted Set this bit to invert the x axis	0x0	RW
	4...3	map_y_axis	Map the y axis to desired axis <b>Value Name Description</b> 0x00 x axis Map to x-axis 0x01 y axis Map to y-axis 0x02 z axis Map to z-axis 0x03 reserved reserved	0x1	RW
	5	map_y_axis_sign	Map the y axis sign to the desired one <b>Value Name Description</b> 0x00 non-inverted Clear this bit to non invert the y axis 0x01 inverted Set this bit to invert the y axis	0x0	RW
	7...6	map_z_axis	Map the z axis to desired axis <b>Value Name Description</b> 0x00 x axis Map to x-axis 0x01 y axis Map to y-axis 0x02 z axis Map to z-axis 0x03 reserved reserved	0x2	RW
	8	map_z_axis_sign	Map the z axis sign to the desired one <b>Value Name Description</b> 0x00 non-inverted Clear this bit to non invert the z axis 0x01 inverted Set this bit to invert the z axis	0x0	RW

**Register (0x5F) INTERNAL\_ERROR**

DESCRIPTION: Internal error flags

RESET: 0x00

 DEFINITION (Go to [register map](#)):

Register (0x5F) INTERNAL_ERROR				
Bit	7	6	5	4
Read/Write	n/a	n/a	n/a	n/a
Reset Value	0	0	0	0
Content	reserved			
Bit	3	2	1	0
Read/Write	n/a	R	R	n/a
Reset Value	0	0	0	0
Content	reserved	int_err_2	int_err_1	reserved

int\_err\_1: Internal error flag - long processing time, processing halted

int\_err\_2: Internal error flag - fatal error, processing halted

**Register (0x6A) NVM\_CONF**

DESCRIPTION: NVM controller mode (Prog/Erase or Read only)

RESET: 0x00

 DEFINITION (Go to [register map](#)):

Register (0x6A) NVM_CONF				
Bit	7	6	5	4
Read/Write	n/a	n/a	n/a	n/a
Reset Value	0	0	0	0
Content	reserved			
Bit	3	2	1	0
Read/Write	n/a	n/a	RW	n/a
Reset Value	0	0	0	0
Content	reserved		nvm_prog_en	reserved

nvm\_prog\_en: Enable NVM programming

nvm_prog_en		
0x00	disable	disable
0x01	enable	enable

**Register (0x6B) IF\_CONF**

DESCRIPTION: Serial interface settings

RESET: 0x00

 DEFINITION (Go to [register map](#)):

Name	Register (0x6B) IF_CONF			
Bit	7	6	5	4
Read/Write	n/a	n/a	n/a	RW
Reset Value	0	0	0	0
Content	reserved			if_mode
Bit	3	2	1	0
Read/Write	n/a	n/a	n/a	RW
Reset Value	0	0	0	0
Content	reserved			spi3

spi3: Configure SPI Interface Mode for primary interface

spi3		
0x00	spi4	SPI 4-wire mode
0x01	spi3	SPI 3-wire mode

if\_mode: Auxiliary interface configuration

if_mode		
0x00	p_auto_s_off	Auxiliary interface:off
0x01	p_auto_s_mag	Auxiliary interface:Magnetometer

**Register (0x6D) ACC\_SELF\_TEST**

DESCRIPTION: Settings for the sensor self-test configuration and trigger

RESET: 0x00

 DEFINITION (Go to [register map](#)):

Name	Register (0x6D) ACC_SELF_TEST			
Bit	7	6	5	4
Read/Write	n/a	n/a	n/a	n/a
Reset Value	0	0	0	0
Content	reserved			
Bit	3	2	1	0
Read/Write	RW	RW	n/a	RW
Reset Value	0	0	0	0
Content	acc_self_test_am p	acc_self_test_sig n	reserved	acc_self_test_en



acc\_self\_test\_en: Enable accelerometer self-test

acc_self_test_en		
0x00	disabled	disabled
0x01	enabled	enabled

acc\_self\_test\_sign: select sign of self-test excitation as

acc_self_test_sign		
0x00	negative	negative
0x01	positive	positive

acc\_self\_test\_amp: select amplitude of the selftest deflection:

acc_self_test_amp		
0x00	low	low
0x01	high	high

### Register (0x70) NV\_CONF

DESCRIPTION: NVM backed configuration bits.

RESET: 0x00

DEFINITION (Go to [register map](#)):

Name	Register (0x70) NV_CONF			
Bit	7	6	5	4
Read/Write	n/a	n/a	n/a	n/a
Reset Value	0	0	0	0
Content	reserved			
Bit	3	2	1	0
Read/Write	RW	RW	RW	RW
Reset Value	0	0	0	0
Content	acc_off_en	i2c_wdt_en	i2c_wdt_sel	spi_en

spi\_en: disable the I2C and enable SPI for the primary interface, when it is in autoconfig mode

spi_en		
0x00	disabled	I2C enabled
0x01	enabled	I2C disabled

i2c\_wdt\_sel: Select timer period for I2C Watchdog

i2c_wdt_sel		
0x00	wdt_short	I2C watchdog timeout after 1.25 ms
0x01	wdt_long	I2C watchdog timeout after 40 ms

i2c\_wdt\_en: I2C Watchdog at the SDI pin in I2C interface mode

<b>i2c_wdt_en</b>		
0x00	Disable	Disable I2C watchdog
0x01	Enable	Enable I2C watchdog

acc\_off\_en: Add the offset defined in the off\_acc\_[xyz] OFFSET register to filtered and unfiltered Accelerometer data

<b>acc_off_en</b>		
0x00	disabled	Disabled
0x01	enabled	Enabled

### Register (0x71) OFFSET\_0

DESCRIPTION: Offset compensation for Accelerometer X-axis (NVM backed)

RESET: 0x00

DEFINITION (Go to [register map](#)):

<b>Name</b>	<b>Register (0x71) OFFSET_0</b>			
Bit	7	6	5	4
Read/Write	RW	RW	RW	RW
Reset Value	0	0	0	0
Content	off_acc_x			
Bit	3	2	1	0
Read/Write	RW	RW	RW	RW
Reset Value	0	0	0	0
Content	off_acc_x			

off\_acc\_x: Accelerometer offset compensation (X-axis).

### Register (0x72) OFFSET\_1

DESCRIPTION: Offset compensation for Accelerometer Y-axis (NVM backed)

RESET: 0x00

DEFINITION (Go to [register map](#)):

<b>Name</b>	<b>Register (0x72) OFFSET_1</b>			
Bit	7	6	5	4
Read/Write	RW	RW	RW	RW
Reset Value	0	0	0	0
Content	off_acc_y			
Bit	3	2	1	0
Read/Write	RW	RW	RW	RW
Reset Value	0	0	0	0
Content	off_acc_y			

off\_acc\_y: Accelerometer offset compensation (Y-axis).

### Register (0x73) OFFSET\_2

DESCRIPTION: Offset compensation for Accelerometer Z-axis (NVM backed)

RESET: 0x00

DEFINITION (Go to [register map](#)):

Name	Register (0x73) OFFSET_2			
Bit	7	6	5	4
Read/Write	RW	RW	RW	RW
Reset Value	0	0	0	0
Content	off_acc_z			
Bit	3	2	1	0
Read/Write	RW	RW	RW	RW
Reset Value	0	0	0	0
Content	off_acc_z			

off\_acc\_z: Accelerometer offset compensation (Z-axis).

### Register (0x7C) PWR\_CONF

DESCRIPTION: Power mode configuration register

RESET: 0x03

DEFINITION (Go to [register map](#)):

Name	Register (0x7C) PWR_CONF			
Bit	7	6	5	4
Read/Write	n/a	n/a	n/a	n/a
Reset Value	0	0	0	0
Content	reserved			
Bit	3	2	1	0
Read/Write	n/a	n/a	RW	RW
Reset Value	0	0	1	1
Content	reserved		fifo_self_wakeup	adv_power_save

adv_power_save		
0x00	aps_off	advanced power save disabled (fast clk always enabled).
0x01	aps_on	advanced power mode enabled (slow clk is active when no measurement is ongoing.)

fifo_self_wakeup		
0x00	fsw_off	FIFO read disabled in advanced power saving mode.
0x01	fsw_on	FIFO read enabled after interrupt in advanced power saving mode.

**Register (0x7D) PWR\_CTRL**

DESCRIPTION: Sensor enable register

RESET: 0x00

DEFINITION (Go to [register map](#)):

Name	Register (0x7D) PWR_CTRL			
Bit	7	6	5	4
Read/Write	n/a	n/a	n/a	n/a
Reset Value	0	0	0	0
Content	reserved			
Bit	3	2	1	0
Read/Write	n/a	RW	n/a	RW
Reset Value	0	0	0	0
Content	reserved	acc_en	reserved	aux_en

aux_en		
0x00	mag_off	Disables the auxiliary sensor.
0x01	mag_on	Enables the auxiliary sensor.

acc_en		
0x00	acc_off	Disables the Accelerometer.
0x01	acc_on	Enables the Accelerometer.

**Register (0x7E) CMD**

DESCRIPTION: Command Register

RESET: 0x00

DEFINITION (Go to [register map](#)):

Name	Register (0x7E) CMD			
Bit	7	6	5	4
Read/Write	RW	RW	RW	RW
Reset Value	0	0	0	0
Content	cmd			
Bit	3	2	1	0
Read/Write	RW	RW	RW	RW
Reset Value	0	0	0	0
Content	cmd			

cmd: Available commands (Note: Register will always read as 0x00):

cmd		
0xa0	nvm_prog	Writes the NVM backed registers into NVM
0xb0	fifo_flush	Clears all data in the FIFO, does not change FIFO_CONFIG and FIFO_DOWNS registers
0xb6	softreset	Triggers a reset, all user configuration settings are overwritten with their default state

## 6. Digital Interfaces

### 6.1. Interfaces

Beside the standard primary interface (I2C and SPI configurable), where sensor acts as a slave to the application processor, BMA425 supports an auxiliary interface. See picture below.

If the auxiliary interface is enabled, the BMA425 can be connected to an external sensor (e.g. a magnetometer) in order to build a 6-DoF solution. Then the BMA425 will act as a master to the external sensor, reading the sensor data automatically and providing it to the application processor via the primary interface.

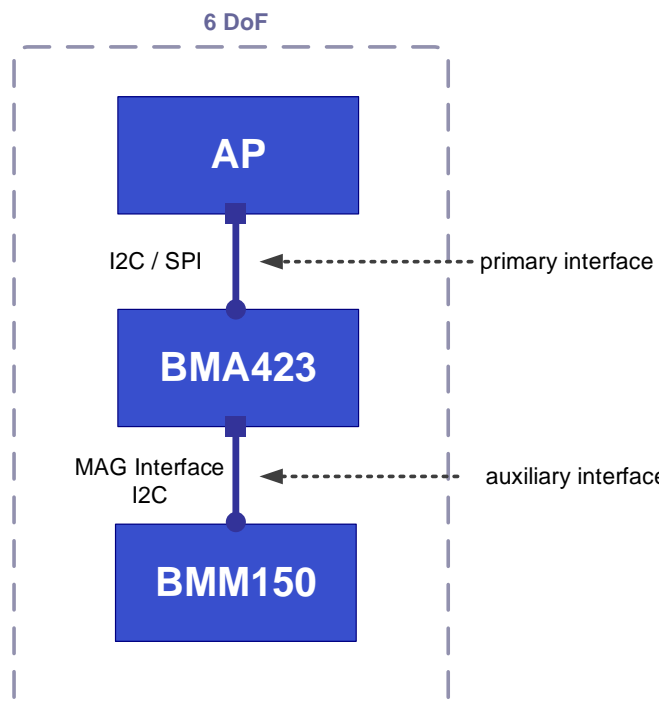

## 6.2. Primary Interface

By default, the BMA425 operates in I2C mode. The BMA425 interface can also be configured to operate in a SPI 4-wire configuration. It can also be re-configured by software to work in 3-wire mode instead of 4-wire mode.

All 3 possible digital interfaces share partly the same pins. The mapping for the primary interface of the BMA425 is given in the following table:

Pin#	Name	I/O Type	Description	Connect to (Primary IF)		
				in SPI4W	in SPI3W	in I2C
1	SDO	Digital I/O	Serial data output in SPI Address select in I <sup>2</sup> C mode see chapter 7.2	SDO	DNC (float)	GND for default I2C addr.
2	SDX	Digital I/O	SDA serial data I/O in I <sup>2</sup> C SDI serial data input in SPI 4W SDA serial data I/O in SPI 3W	SDI	SDA	SDA
5	INT1	Digital I/O	Interrupt output 1 (default) (Input for external FIFO sync) *	INT1 (FIFO sync)	INT1 (FIFO sync)	INT1 (FIFO sync)
6	INT2	Digital I/O	Interrupt output 2 (default) (Input for external FIFO sync) *	INT2 (FIFO sync)	INT2 (FIFO sync)	INT2 (FIFO sync)
10	CSB	Digital in	Chip select for SPI mode	CSB	CSB	V <sub>DDIO</sub> or DNC (float)
12	SCX	Digital in	SCK for SPI serial clock SCL for I <sup>2</sup> C serial clock	SCK	SCK	SCL

\* INT1 and/or INT2 can also be configured as an input in case the external data synchronization in FIFO is used. See chapter 0. If INT1 and/or INT2 are not used, please do not connect them (DNC).

The following table shows the electrical specifications of the interface pins:

Parameter	Symbol	Condition	Min	Typ	Max	Units
Pull-up Resistance, CSB pin	R <sub>up</sub>	Internal Pull-up Resistance to VDDIO	75	100	125	kΩ
Input Capacitance	C <sub>in</sub>				5	pF
I <sup>2</sup> C Bus Load Capacitance (max. drive capability)	C <sub>I2C_Load</sub>				400	pF

### 6.3. Primary Interface I2C/SPI Protocol Selection

The protocol is automatically selected based on the chip select CSB pin behavior after power-up.

At reset / power-up, BMA425 is in I2C mode. If CSB is connected to VDDIO during power-up and not changed the sensor interface works in I2C mode. For using I2C, it is recommended to hard-wire the CSB line to VDDIO. Since power-on-reset is only executed when, both VDD and VDDIO are established, there is no risk of incorrect protocol detection due to power-up sequence.

If CSB sees a rising edge after power-up, the BMA425 interface switches to SPI until a reset or the next power-up occurs. Therefore, a CSB rising edge is needed before starting the SPI communication. Hence, it is recommended to perform a SPI single read of register [CHIP\\_ID](#) (the obtained value will be invalid) before the actual communication start, in order to use the SPI interface.

If toggling of the CSB bit is not possible without data communication, there is in addition the spi\_en bit in Register [NV\\_CONF](#), which can be used to permanently set the primary interface to SPI without the need to toggle the CSB pin at every power-up or reset.

### 6.4. SPI interface and protocol

The timing specification for SPI of the BMA425 is given in the following table:

SPI timing, valid at  $V_{DDIO} \geq 1.71V$

Parameter	Symbol	Condition	Min	Max	Units
Clock Frequency	$f_{SPI}$	Max. Load on SDI or SDO = 30pF, $V_{DDIO} \geq 1.62V$		10	MHz
		$V_{DDIO} < 1.62V$		7	MHz
SCK Low Pulse	$t_{SCKL}$	$V_{DDIO} \geq 1.62V$	45		ns
SCK High Pulse	$t_{SCKH}$	$V_{DDIO} \geq 1.62V$	45		ns
SCK Low Pulse	$t_{SCKL}$	$V_{DDIO} < 1.62V$		66	ns
SCK High Pulse	$t_{SCKH}$	$V_{DDIO} < 1.62V$		66	ns
SDI Setup Time	$t_{SDI\_setup}$		20		ns
SDI Hold Time	$t_{SDI\_hold}$		20		ns
SDO Output Delay	$t_{SDO\_OD}$	Load = 30pF, $V_{DDIO} \geq 1.62V$		30	ns
CSB Setup Time	$t_{CSB\_setup}$		40		ns
CSB Hold Time	$t_{CSB\_hold}$		40		ns
Idle time between write accesses, suspend mode, low-power mode 1	$t_{IDLE\_wacc\_sum}$		1000		$\mu s$
Idle time after write and read access, active state	$t_{IDLE\_wr\_act}$		2		$\mu s$



The following figure shows the definition of the SPI timings:

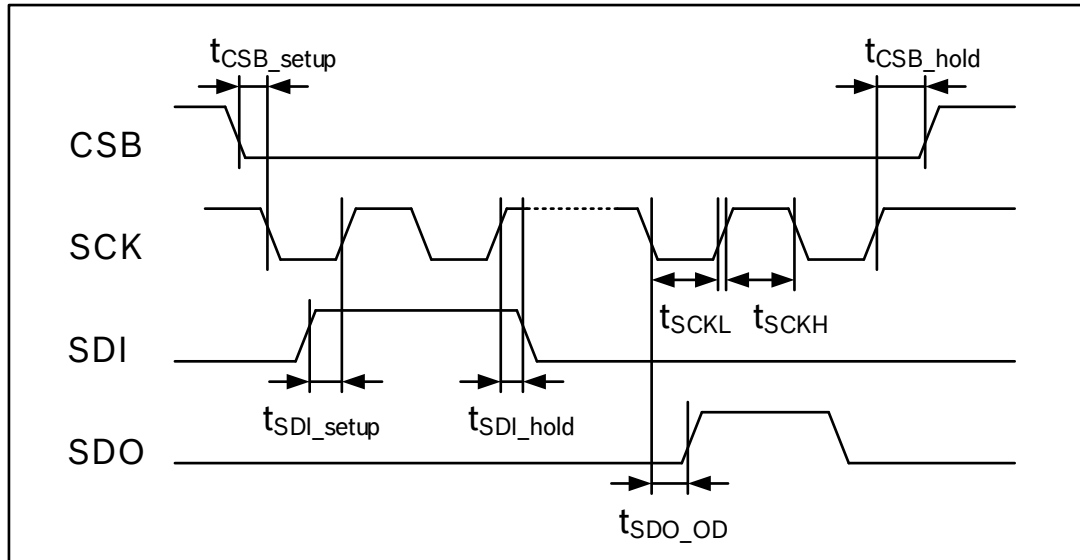

SPI timing diagram

The SPI interface of the BMA425 is compatible with two modes, '00' [CPOL = '0' and CPHA = '0'] and '11' [CPOL = '1' and CPHA = '1']. The automatic selection between '00' and '11' is controlled based on the value of SCK after a falling edge of CSB.

Two configurations of the SPI interface are supported by the BMA425: 4-wire and 3-wire. The same protocol is used by both configurations. The device operates in 4-wire configuration by default. It can be switched to 3-wire configuration by writing [IF\\_CONF.spi3](#) = 0b1. Pin SDI is used as the common data pin in 3-wire configuration.

For single byte read as well as write operations, 16-bit protocols are used. The BMA425 also supports multiple-byte read and write operations.

**In SPI 4-wire configuration** CSB (chip select low active), SCK (serial clock), SDI (serial data input), and SDO (serial data output) pins are used. The communication starts when the CSB is pulled low by the SPI master and stops when CSB is pulled high. SCK is also controlled by SPI master. SDI and SDO are driven at the falling edge of SCK and should be captured at the rising edge of SCK.

The basic write operation waveform for 4-wire configuration is depicted in the following figure. During the entire write cycle SDO remains in high-impedance state.

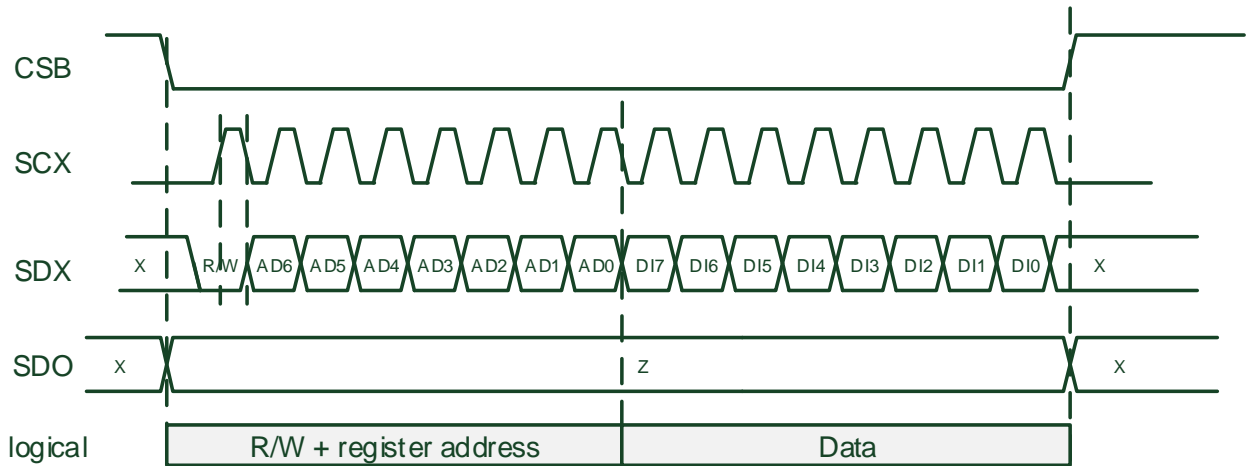

4-wire basic SPI write sequence (mode '00')

Multiple write operations are possible by keeping CSB low and continuing the data transfer. Only the first register address has to be written. Addresses are automatically incremented after each write access as long as CSB stays active low. The principle of multiple write is shown in figure below:

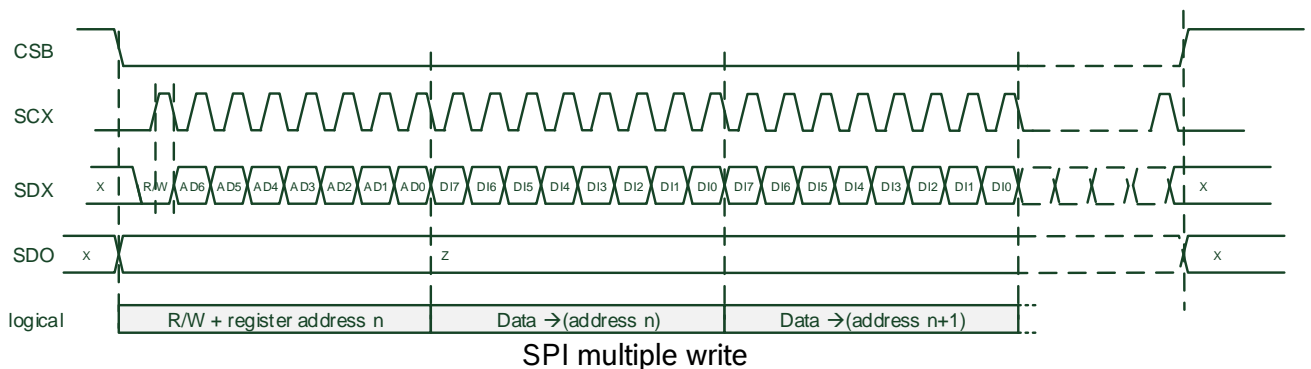

SPI multiple write

The basic read operation waveform for 4-wire configuration is depicted in the figure below. Please note that the first byte received from the BMA425 via the SDO line correspond to a dummy byte and the 2<sup>nd</sup> byte correspond to the value read out of the specified register address. That means, for a basic read operation two bytes have to be read and the first has to be dropped and the second byte must be interpreted.

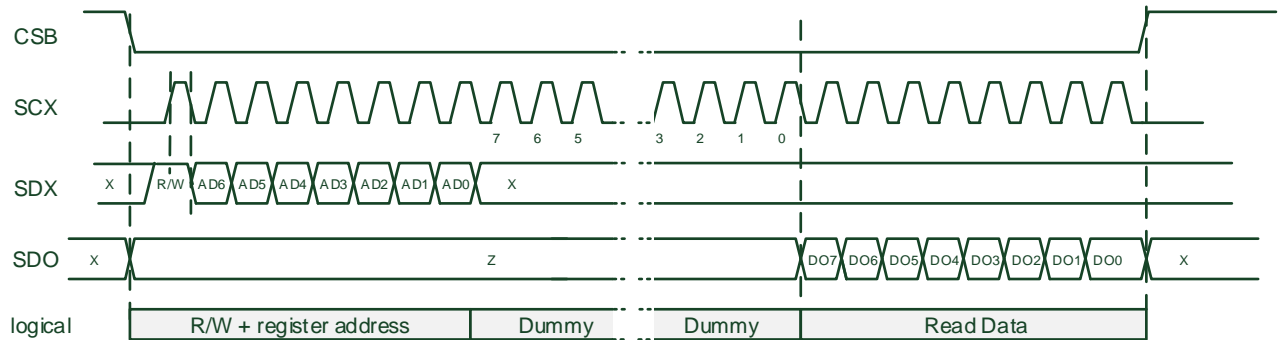

4-wire basic SPI read sequence (mode '00')

The data bits are used as follows:

R/W: Read/Write bit. When 0, the data SDI is written into the chip. When 1, the data SDO from the chip is read.

AD6-AD0: Address

DI7-DI0: When in write mode, these are the data SDI, which will be written into the address.

DO7-DO0: When in read mode, these are the data SDO, which are read from the address.

Multiple read operations are possible by keeping CSB low and continuing the data transfer. Only the first register address has to be written. Addresses are automatically incremented after each read access as long as CSB stays active low. Please note that the first byte received from the BMA425 via the SDO line correspond to a dummy byte and the 2<sup>nd</sup> byte correspond to the value read out of the specified register address. The successive bytes read out correspond to values of incremented register addresses. That means, for a multiple read operation of n bytes, n+1 bytes have to be read, the first has to be dropped and the successive bytes must be interpreted.

**In SPI 3-wire configuration** CSB (chip select low active), SCK (serial clock), and SDI (serial data input and output) pins are used. While SCK is high, the communication starts when the CSB is pulled low by the SPI master and stops when CSB is pulled high. SCK is also controlled by SPI master. SDI is driven (when used as input of the device) at the falling edge of SCK and should be captured (when used as the output of the device) at the rising edge of SCK.

The protocol as such is the same in 3-wire configuration as it is in 4-wire configuration. The basic operation wave-form (read or write access) for 3-wire configuration is depicted in the figure below:

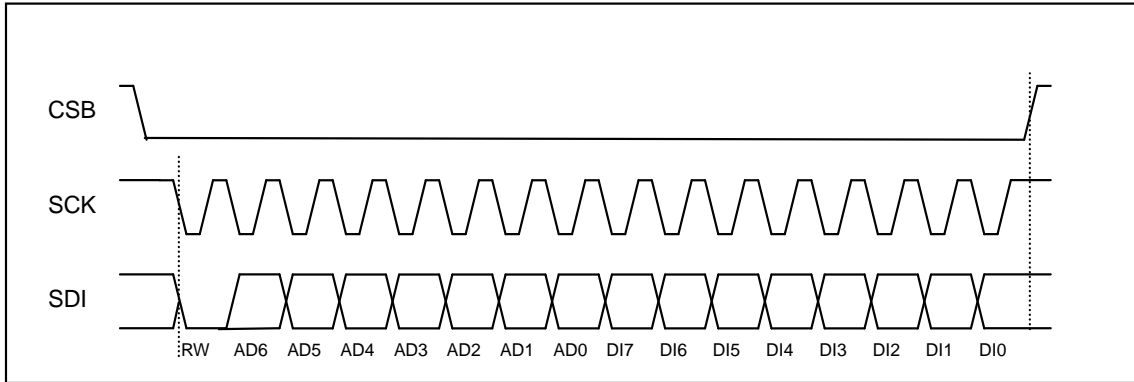

3-wire basic SPI read or write sequence (mode '11')

## 6.5. Primary I2C Interface

The I<sup>2</sup>C bus uses SCL (= SCx pin, serial clock) and SDA (= SDx pin, serial data input and output) signal lines. Both lines are connected to V<sub>DDIO</sub> externally via pull-up resistors so that they are pulled high when the bus is free.

The default I<sup>2</sup>C address of the device is 0b00011000 (0x18). It is used if the SDO pin is pulled to 'GND'. The alternative address 0b00011001 (0x19) is selected by pulling the SDO pin to 'VDDIO'.

The I<sup>2</sup>C interface of the BMA425 is compatible with the I<sup>2</sup>C Specification UM10204 Rev. 03 (19 June 2007), available at <http://www.nxp.com>. The BMA425 supports **I<sup>2</sup>C standard mode and fast mode**, only 7-bit address mode is supported. For V<sub>DDIO</sub> = 1.2V to 1.62 V the guaranteed voltage output levels are slightly relaxed as described in Table 1 of the electrical specification section.

BMA425 also supports an **extended I<sup>2</sup>C mode** that allows using clock frequencies up to 1 MHz. In this mode all timings of the fast mode apply and it additionally supports clock frequencies up to 1MHz.

The timing specification for I<sup>2</sup>C of the BMA425 is given in the following table:

Parameter	Symbol	Condition	Min	Max	Units
Clock Frequency	f <sub>SCL</sub>			1000	kHz
SCL Low Period	t <sub>LOW</sub>		1.3		μs
SCL High Period	t <sub>HIGH</sub>		0.6		
SDA Setup Time	t <sub>SUDAT</sub>		0.1		
SDA Hold Time	t <sub>HDDAT</sub>		0.0		
Setup Time for a repeated Start Condition	t <sub>SUSTA</sub>		0.6		
Hold Time for a Start Condition	t <sub>HDSTA</sub>		0.6		
Setup Time for a Stop Condition	t <sub>SUSTO</sub>		0.6		
Time before a new Transmission can start	t <sub>BUF</sub>	low power mode	400		
		normal mode	1.3		
Idle time between write accesses, normal mode, standby mode, low-power mode	t <sub>IDLE_wacc_n</sub> <sub>m</sub>	low power mode	1000		
		normal mode	1.3		
Idle time between write accesses, suspend mode, low-power mode	t <sub>IDLE_wacc_s</sub> <sub>um</sub>		1000		



The figure below shows the definition of the I<sup>2</sup>C timings given in Table 28:

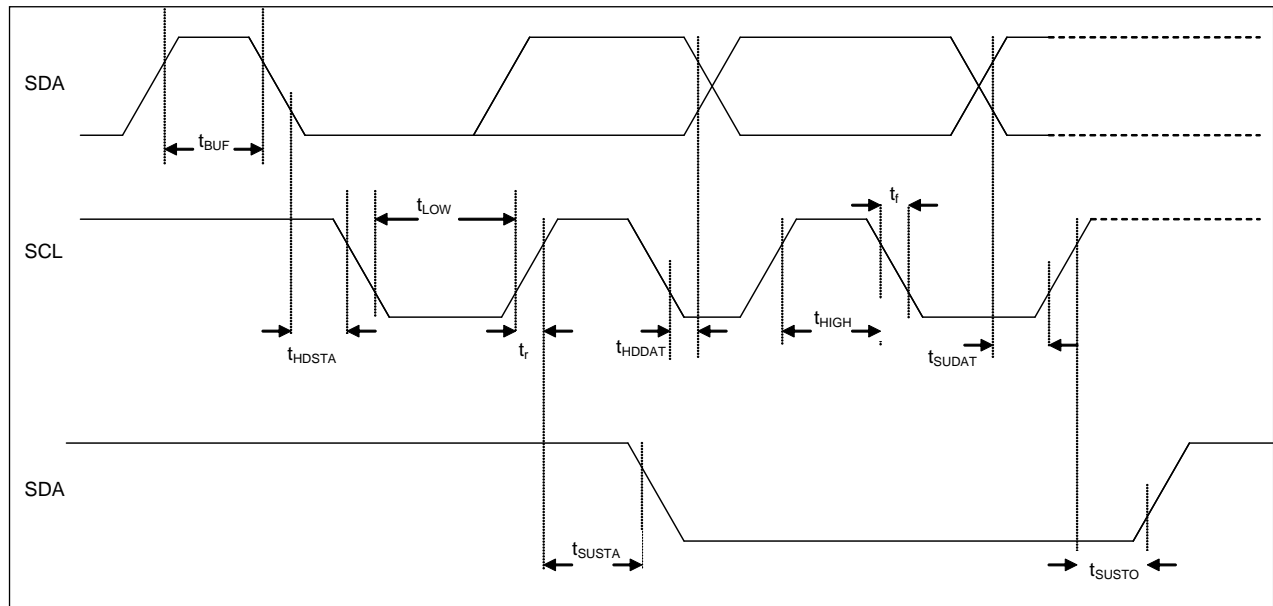

I<sup>2</sup>C timing diagram

The I<sup>2</sup>C protocol works as follows:

**START:** Data transmission on the bus begins with a high to low transition on the SDA line while SCL is held high (start condition (S) indicated by I<sup>2</sup>C bus master). Once the START signal is transferred by the master, the bus is considered busy.

**STOP:** Each data transfer should be terminated by a Stop signal (P) generated by master. The STOP condition is a low to high transition on SDA line while SCL is held high.

**ACKS:** Each byte of data transferred must be acknowledged. It is indicated by an acknowledge bit sent by the receiver. The transmitter must release the SDA line (no pull down) during the acknowledge pulse while the receiver must then pull the SDA line low so that it remains stable low during the high period of the acknowledge clock cycle.

In the following diagrams these abbreviations are used:

- S Start
- P Stop
- ACKS Acknowledge by slave
- ACKM Acknowledge by master
- NACKM Not acknowledge by master
- RW Read / Write

A START immediately followed by a STOP (without SCL toggling from 'VDDIO' to 'GND') is not supported. If such a combination occurs, the STOP is not recognized by the device.





**I<sup>2</sup>C write access:**

I<sup>2</sup>C write access can be used to write a data byte in one sequence.

The sequence begins with start condition generated by the master, followed by 7 bits slave address and a write bit (RW = 0). The slave sends an acknowledge bit (ACKS = 0) and releases the bus. Then the master sends the one byte register address. The slave again acknowledges the transmission and waits for the 8 bits of data which shall be written to the specified register address. After the slave acknowledges the data byte, the master generates a stop signal and terminates the writing protocol.

Example of an I<sup>2</sup>C write access:

Start	Slave Address							R/W	ACK		Register address (0x41)							ACK	Register data (0x01)							ACK	Stop			
S	0	0	1	1	0	0	0	0	X		1	0	0	0	0	0	1	0	0	0	0	0	0	0	0	0	0	1	0	P

 Master -> Slave  
 Slave -> Master

I<sup>2</sup>C write

Multi-byte writes are supported without restriction on normal registers with auto-increment, on special registers with address trap.

**I<sup>2</sup>C read access:**

I<sup>2</sup>C read access also can be used to read one or multiple data bytes in one sequence.

A read sequence consists of a one-byte I<sup>2</sup>C write phase followed by the I<sup>2</sup>C read phase. The two parts of the transmission must be separated by a repeated start condition (S). The I<sup>2</sup>C write phase addresses the slave and sends the register address to be read. After slave acknowledges the transmission, the master generates again a start condition and sends the slave address together with a read bit (RW = 1). Then the master releases the bus and waits for the data bytes to be read out from slave. After each data byte the master has to generate an acknowledge bit (ACKS = 0) to enable further data transfer. A NACKM (ACKS = 1) from the master stops the data being transferred from the slave. The slave releases the bus so that the master can generate a STOP condition and terminate the transmission. The register address is automatically incremented and, therefore, more than one byte can be sequentially read out. Once a new data read transmission starts, the start address will be set to the register address specified since the latest I<sup>2</sup>C write command. By default the start address is set at 0x00. In this way repetitive multi-bytes reads from the same starting address are possible.



Start	Slave I2C ID								R/W	ACK	Register address (0x12)								ACK
S	0	0	1	1	0	0	0	0	0	X	0	0	1	0	0	1	0	0	

Repeat Start	Slave I2C ID	R/W	ACK	Data byte								ACK	Data byte								ACK							
				Register data - address 0x12									Register data - address 0x13															
Sr	0	0	1	1	0	0	0	1	0	X	X	X	X	X	X	X	X	0	X	X	X	X	X	X	X	X	0	...

	Slave I2C ID	R/W	ACK	Data byte								ACK	Data byte								ACK							
				Register data - address 0x14									Register data - address 0x15															
...										X	X	X	X	X	X	X	X	0	X	X	X	X	X	X	X	X	0	...

Master -> Slave  
 Slave -> Master

	Slave I2C ID	R/W	ACK	Data byte								ACK	Data byte								NACK	Stop						
				Register data - address 0x16									Register data - address 0x17															
...										X	X	X	X	X	X	X	X	0	X	X	X	X	X	X	X	X	1	P

In order to prevent the I<sup>2</sup>C slave of the device to lock-up the I<sup>2</sup>C bus, a watchdog timer (WDT) is implemented. The WDT observes internal I<sup>2</sup>C signals and resets the I<sup>2</sup>C interface if the bus is locked-up by the BMA425. The activity and the timer period of the WDT can be configured through the bits [NV\\_CONF.i2c\\_wdt\\_en](#) and [NV\\_CONF.i2c\\_wdt\\_sel](#).



## 6.6. SPI and I<sup>2</sup>C Access Restrictions

In order to allow for the correct internal synchronization of data written to the BMA425, certain access restrictions apply for consecutive write accesses or a write/read sequence through the SPI as well as I2C interface. The required waiting period depends on whether the device is operating in normal mode or other modes.

As illustrated in the figure below, an interface idle time of at least 2  $\mu\text{s}$  is required following a write operation when the device operates in normal mode. In suspend mode an interface idle time of at least 1000  $\mu\text{s}$  is required.

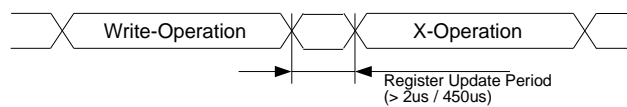

Post-Write Access Timing Constraints

## 6.7. Auxiliary Interface

The BMA425 allows attaching an external sensor (MAG-sensor) to a BMA425 via the auxiliary interface. The connection diagrams for the auxiliary interface are depicted in the chapter 7.3. The timings of the secondary I2C interface are the same as for the primary I2C interface, see chapter 6.5.

BM423 acts as a master of the secondary interface, controls the data acquisition of the MAG-sensor (slave of the secondary interface) and presents the data to the application processor (AP) in the user registers of the BMA425 through the primary interface. No external pull-up resistors need to be connected, since an internal pull-up can be configured in the BMA425 (default value: internal pull-up is off, please contact your regional sales representative if you want to use this functionality). No additional I2C master or slave devices must be attached to the magnetometer interfaces.

The BMA425 autonomously reads out the sensor data from BMM150 without intervention of the AP and stores the data in its data registers (per default) and FIFO (see Register [FIFO CONFIG 1.fifo aux en](#)). The initial setup of the BMM150 after power-on is done through indirect addressing in the BMA425. From a system perspective the initialization for BMM150 when attached to BMA425 should be possible within 100ms.

More information about the usage of Auxiliary Interface can be found in chapter 4.8.

## 7. Pin-out and Connection Diagrams

### 7.1. Pin-out

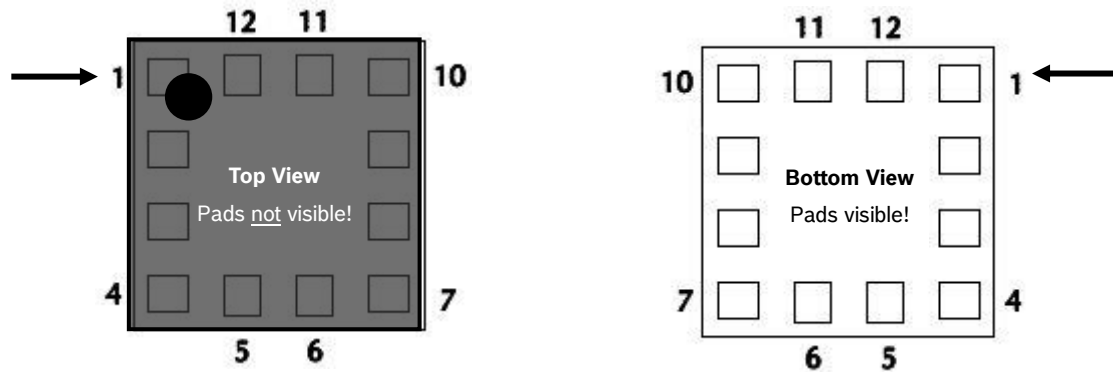

### Pin description

Pin#	Name	I/O Type	Description	Connect to		
				in SPI 4W	In SPI 3W	in I <sup>2</sup> C
1	SDO	Digital I/O	Serial data output in SPI Address select in I <sup>2</sup> C mode see chapter 7.2	SDO	DNC (float)	GND for default I <sup>2</sup> C addr.
2	SDX	Digital I/O	SDA serial data I/O in I <sup>2</sup> C SDI serial data input in SPI 4W SDA serial data I/O in SPI 3W	SDI	SDA	SDA
3	VDDIO	Supply	Digital I/O supply voltage (1.2V ... 3.6V)	V <sub>DDIO</sub>	V <sub>DDIO</sub>	V <sub>DDIO</sub>
4	ASDA	Digital I/O	Serial data I/O – Secondary Interface (I <sup>2</sup> C Master for Magnetometer)	V <sub>DDIO</sub> / GNDIO/NC or (ASDA - Secondary interface)	V <sub>DDIO</sub> / GNDIO/NC or (ASDA - Secondary interface)	V <sub>DDIO</sub> / GNDIO/NC or (ASDA - Secondary interface)
5	INT1	Digital I/O	Interrupt output 1 (default) (Input for external FIFO sync) *	INT1 (FIFO sync)	INT1 (FIFO sync)	INT1 (FIFO sync)
6	INT2	Digital I/O	Interrupt output 2 (default) (Input for external FIFO sync) *	INT2 (FIFO sync)	INT2 (FIFO sync)	INT2 (FIFO sync)
7	VDD	Supply	Power supply for analog & digital domain (1.62V ... 3.6V)	V <sub>DD</sub>	V <sub>DD</sub>	V <sub>DD</sub>
8	GNDIO	Ground	Ground for I/O	GND	GND	GND
9	GND	Ground	Ground for digital & analog	GND	GND	GND
10	CSB	Digital in	Chip select for SPI mode	CSB	CSB	V <sub>DDIO</sub> or DNC (float)
11	ASCL	Digital out	Digital clock (out) – Secondary Interface (I <sup>2</sup> C Master for Magnetometer)	V <sub>DDIO</sub> / GNDIO/NC or (ASCL - Secondary interface)	V <sub>DDIO</sub> / GNDIO/ NC or (ASCL - Secondary interface)	V <sub>DDIO</sub> / GNDIO/ NC or (ASCL - Secondary interface)
12	SCX	Digital in	SCK for SPI serial clock SCL for I <sup>2</sup> C serial clock	SCK	SCK	SCL

\* INT1 and/or INT2 can also be configured as an input in case the external data synchronization in FIFO is used. See chapter 4.5. If INT1 and/or INT2 are not used, please do not connect them (DNC).

## 7.2. Connection Diagrams without Auxiliary Interface

### SPI

#### 3-wire

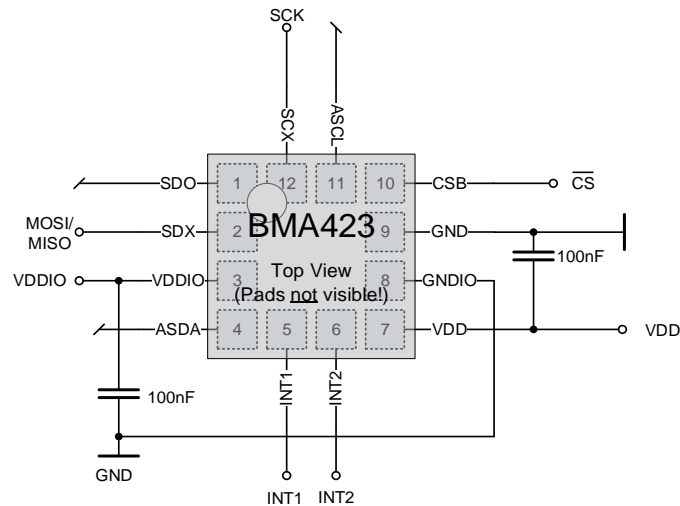

It is recommended to use 100nF decoupling capacitors at pin 3 (VDDIO) and pin 7 (VDD).

#### 4-wire

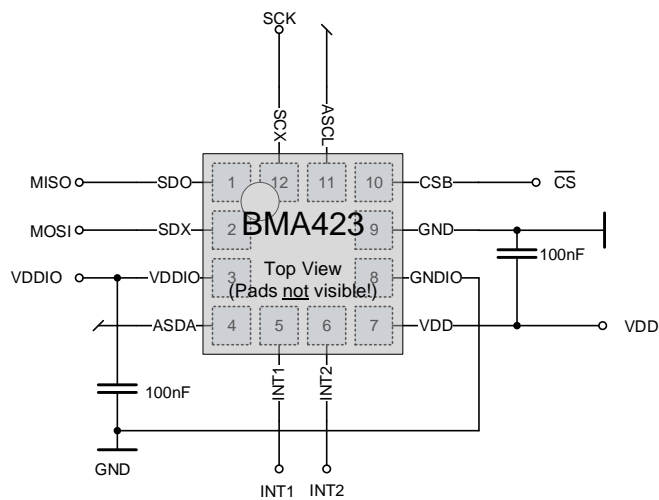

It is recommended to use 100nF decoupling capacitors at pin 3 (VDDIO) and pin 7 (VDD).

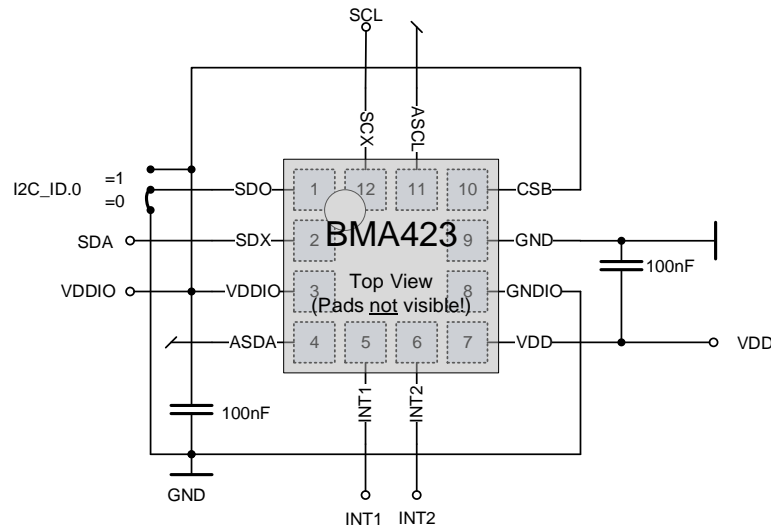
**I2C**

It is recommended to use 100nF decoupling capacitors at pin 3 (VDDIO) and pin 7 (VDD).

**7.3. Connection Diagrams with Auxiliary Interface**
**SPI**

3-wire

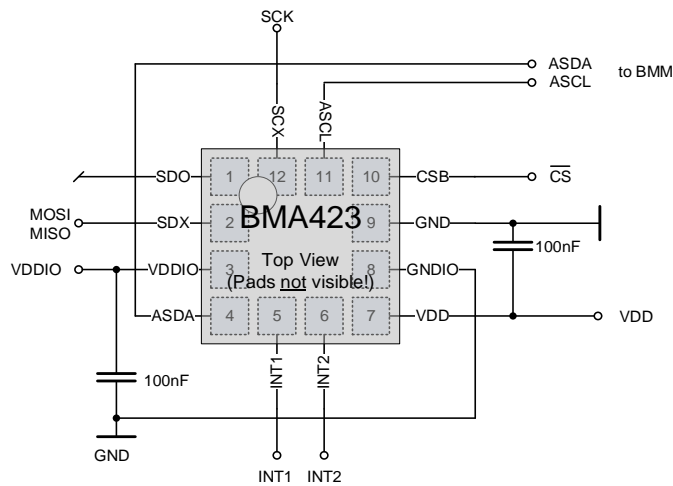

It is recommended to use 100nF decoupling capacitors at pin 3 (VDDIO) and pin 7 (VDD).

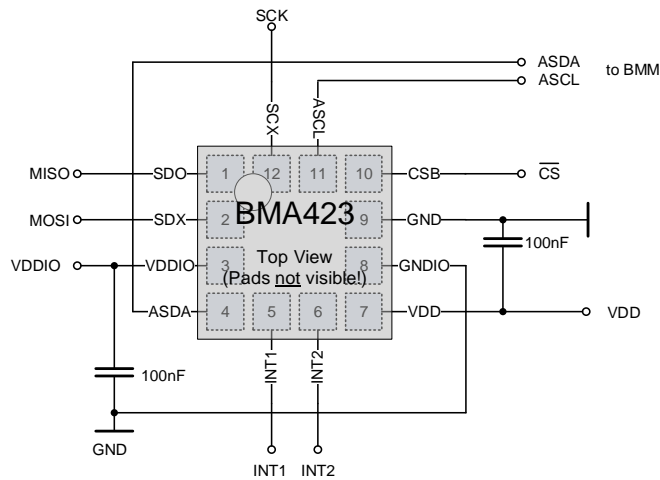
**4-wire**

It is recommended to use 100nF decoupling capacitors at pin 3 (VDDIO) and pin 7 (VDD).

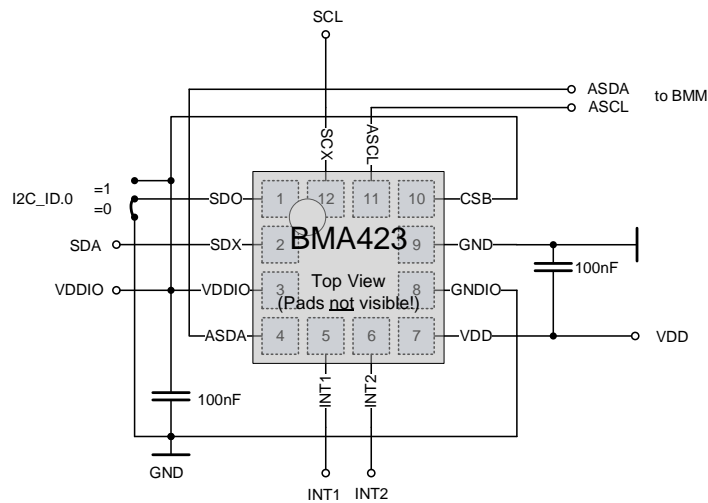
**I2C**

It is recommended to use 100nF decoupling capacitors at pin 3 (VDDIO) and pin 7 (VDD).



## 8.2. Sensing axis orientation

If the sensor is accelerated in the indicated directions, the corresponding channel will deliver a positive acceleration signal (dynamic acceleration). If the sensor is at rest and the force of gravity is acting along the indicated directions, the output of the corresponding channel will be negative (static acceleration).

Example: If the sensor is at rest or at uniform motion in a gravity field according to the figure given below, the output signals are:

- $\pm 0g$  for the X channel
- $\pm 0g$  for the Y channel
- $+ 1g$  for the Z channel

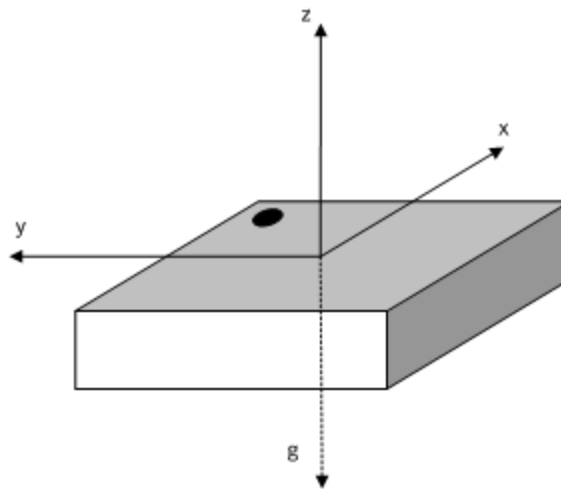

The following table lists all corresponding output signals on X, Y, and Z while the sensor is at rest or at uniform motion in a gravity field under assumption of a  $\pm 4g$  range setting, a 12 bit resolution, and a top down gravity vector as shown above.

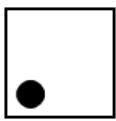
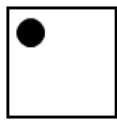
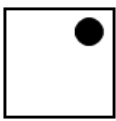
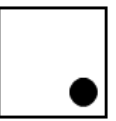
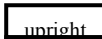
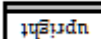
Sensor Orientation (gravity vector ↓)						
Output Signal X	0g / 0 LSB	1g / 511 LSB	0g / 0 LSB	-1g / -512 LSB	0g / 0 LSB	0g / 0 LSB
Output Signal Y	-1g / -512 LSB	0g / 0 LSB	1g / 511 LSB	0g / 0 LSB	0g / 0 LSB	0g / 0 LSB
Output Signal Z	0g / 0 LSB	0g / 0 LSB	0g / 0 LSB	0g / 0 LSB	1g / 511 LSB	-1g / -512 LSB

For reference the figure below shows the Android device orientation with an integrated BMA425.

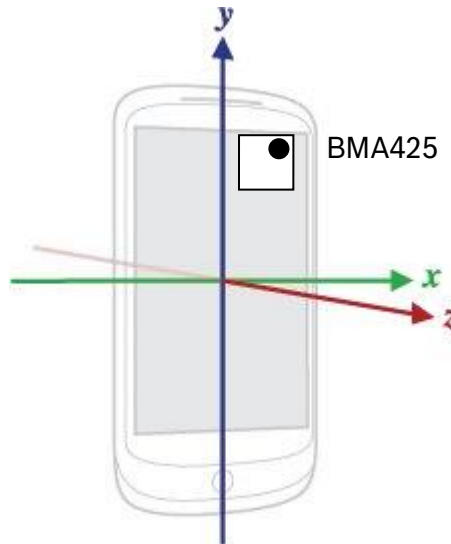





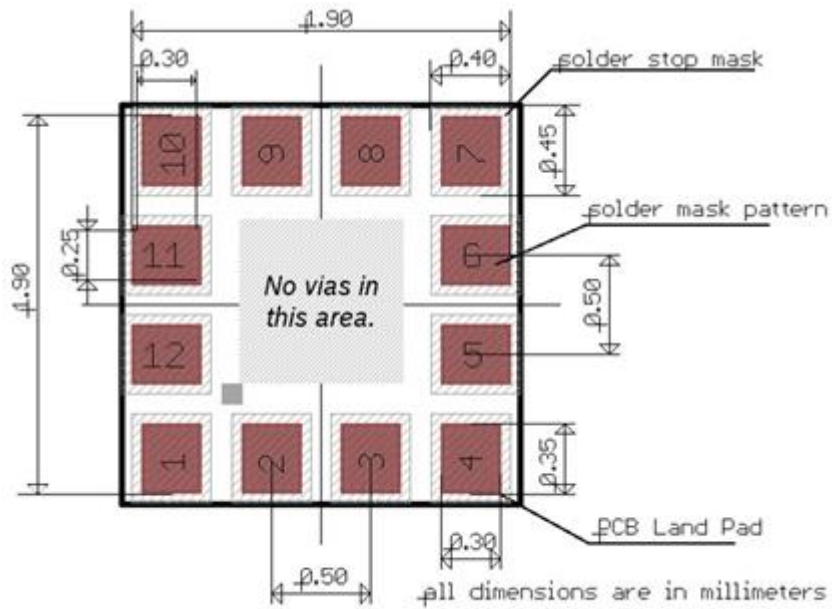

### 8.3. Landing pattern recommendation

The recommended landing pattern for the BMA425 on customer's PCB is given in the following figure. It is recommended to avoid any wiring underneath the BMA425 (shaded area).



**Landing pattern recommendation**

**8.4. Marking****Mass production**

Labeling	Name	Symbol	Remark
	Internal Code	ZZ	internal
	Counter ID	CCC	3 alphanumeric digits, variable to generate trace-code.
	Pin 1 identifier top side	●	--

**Engineering samples**

Labeling	Name	Symbol	Remark
	Internal Code	X	internal
	Eng. sample ID	E, N	2 alphanumeric digits, fixed to identify engineering sample, N = "C"
	Sample ID	CC	2 alphanumeric digits, variable to generate trace-code.
	Pin 1 identifier top side	●	--

### 8.5. Soldering guidelines

The moisture sensitivity level of the BMA425E sensors corresponds to JEDEC Level 1, see also

- IPC/JEDEC J-STD-020C "Joint Industry Standard: Moisture/Reflow Sensitivity Classification for non-hermetic Solid State Surface Mount Devices"
- IPC/JEDEC J-STD-033A "Joint Industry Standard: Handling, Packing, Shipping and Use of Moisture/Reflow Sensitive Surface Mount Devices"

The sensor fulfils the lead-free soldering requirements of the above-mentioned IPC/JEDEC standard, i.e. reflow soldering with a peak temperature up to 260°C.

Profile Feature	Pb-Free Assembly
Average Ramp-Up Rate ( $T_{s_{max}}$ to $T_p$ )	3° C/second max.
<b>Preheat</b> - Temperature Min ( $T_{s_{min}}$ ) - Temperature Max ( $T_{s_{max}}$ ) - Time ( $t_{s_{min}}$ to $t_{s_{max}}$ )	150 °C 200 °C 60-180 seconds
Time maintained above: - Temperature ( $T_L$ ) - Time ( $t_L$ )	217 °C 60-150 seconds
Peak/Classification Temperature ( $T_p$ )	260 °C
Time within 5 °C of actual Peak Temperature ( $t_p$ )	20-40 seconds
Ramp-Down Rate	6 °C/second max.
Time 25 °C to Peak Temperature	8 minutes max.

Note 1: All temperatures refer to fopside of the package, measured on the package body surface.

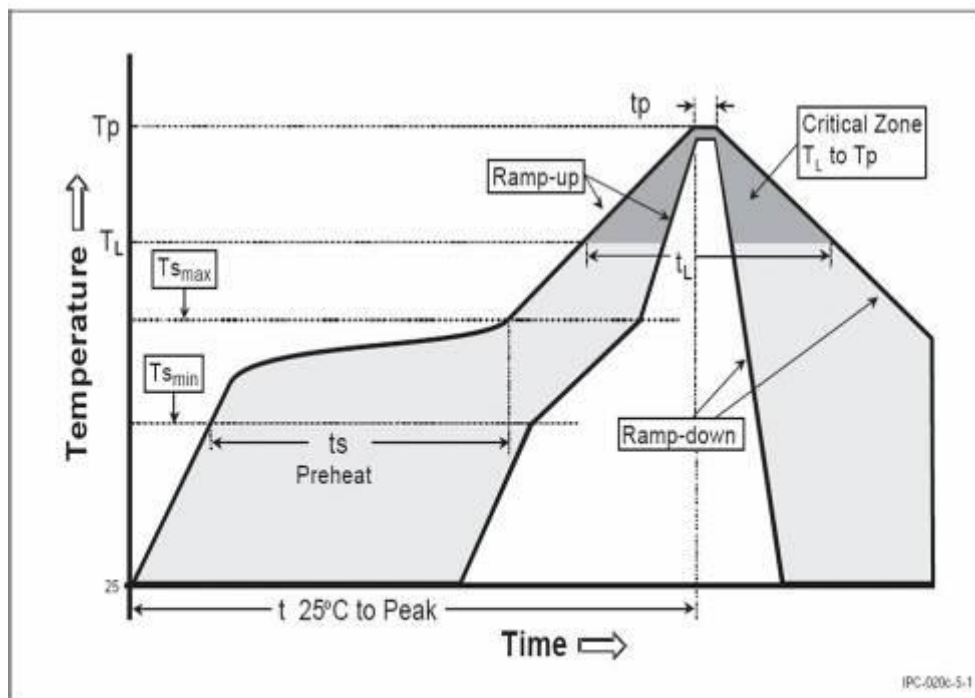

## 8.6. Handling instructions

Micromechanical sensors are designed to sense acceleration with high accuracy even at low amplitudes and contain highly sensitive structures inside the sensor element. The MEMS sensor can tolerate mechanical shocks up to several thousand g's. However, these limits might be exceeded in conditions with extreme shock loads such as e.g. hammer blow on or next to the sensor, dropping of the sensor onto hard surfaces etc.

We recommend to avoid g-forces beyond the specified limits during transport, handling and mounting of the sensors in a defined and qualified installation process.

This device has built-in protections against high electrostatic discharges or electric fields (e.g. 2kV HBM); however, anti-static precautions should be taken as for any other CMOS component. Unless otherwise specified, proper operation can only occur when all terminal voltages are kept within the supply voltage range. Unused inputs must always be tied to a defined logic voltage level.

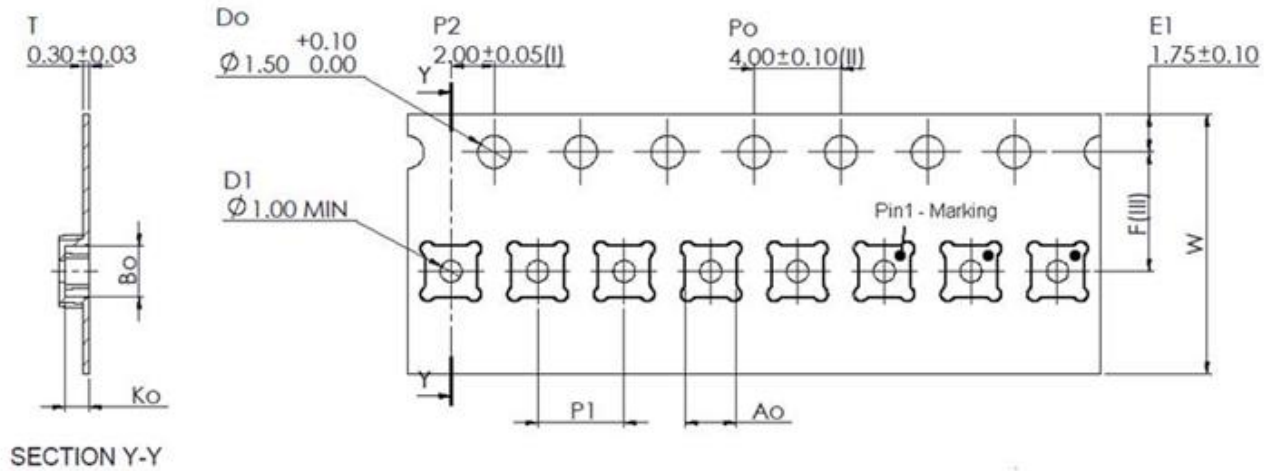
**8.7. Tape and Reel specification**

Ao	2.35	+/- 0.05
Bo	2.30	+/- 0.05
Ko	1.10	+/- 0.05
F	5.50	+/- 0.05
P1	4.00	+/- 0.10
W	12.00	+0.30 / -0.10

## 8.8. Environmental safety

The BMA425 sensor meets the requirements of the EC restriction of hazardous substances (RoHS) directive, see also:

*Directive 2011/65/EU of the European Parliament and of the Council of 8 September 2011 on the restriction of the use of certain hazardous substances in electrical and electronic equipment.*

### Halogen content

The BMA425 is halogen-free. For more details on the corresponding analysis results please contact your Bosch Sensortec representative.

### Internal package structure

Within the scope of Bosch Sensortec's ambition to improve its products and secure the mass product supply, Bosch Sensortec qualifies additional sources (e.g. 2<sup>nd</sup> source) for the LGA package of the BMA425.

While Bosch Sensortec took care that all of the technical packages parameters are described above are 100% identical for all sources, there can be differences in the chemical content and the internal structural between the different package sources.

However, as secured by the extensive product qualification process of Bosch Sensortec, this has no impact to the usage or to the quality of the BMA425 product.

## 9. Legal disclaimer

### 9.1. Engineering samples

Engineering Samples are marked with an asterisk (\*) or (e). Samples may vary from the valid technical specifications of the product series contained in this data sheet. They are therefore not intended or fit for resale to third parties or for use in end products. Their sole purpose is internal client testing. The testing of an engineering sample may in no way replace the testing of a product series. Bosch Sensortec assumes no liability for the use of engineering samples. The Purchaser shall indemnify Bosch Sensortec from all claims arising from the use of engineering samples.

### 9.2. Product use

Bosch Sensortec products are developed for the consumer goods industry. They may only be used within the parameters of this product data sheet. They are not fit for use in life-sustaining or security sensitive systems. Security sensitive systems are those for which a malfunction is expected to lead to bodily harm or significant property damage. In addition, they are not fit for use in products which interact with motor vehicle systems.

The resale and/or use of products are at the purchaser's own risk and his own responsibility. The examination of fitness for the intended use is the sole responsibility of the Purchaser.

The purchaser shall indemnify Bosch Sensortec from all third party claims arising from any product use not covered by the parameters of this product data sheet or not approved by Bosch Sensortec and reimburse Bosch Sensortec for all costs in connection with such claims.

The purchaser must monitor the market for the purchased products, particularly with regard to product safety, and inform Bosch Sensortec without delay of all security relevant incidents.

### 9.3. Application examples and hints

With respect to any examples or hints given herein, any typical values stated herein and/or any information regarding the application of the device, Bosch Sensortec hereby disclaims any and all warranties and liabilities of any kind, including without limitation warranties of non-infringement of intellectual property rights or copyrights of any third party. The information given in this document shall in no event be regarded as a guarantee of conditions or characteristics. They are provided for illustrative purposes only and no evaluation regarding infringement of intellectual property rights or copyrights or regarding functionality, performance or error has been made.



## 10.Document history and modification

Rev. No	Chapter	Description of modification/changes	Date
1.0		Document creation	26 March 2018

Bosch Sensortec GmbH  
Gerhard-Kindler-Strasse 9  
72770 Reutlingen / Germany

[contact@bosch-sensortec.com](mailto:contact@bosch-sensortec.com)  
[www.bosch-sensortec.com](http://www.bosch-sensortec.com)

Modifications reserved | Printed in Germany  
Specifications subject to change without notice  
Document number: BST-BMA425-DS000-00  
Revision\_1.0\_March\_2018