

FEATURES

- 40V complementary device
- High h_{FE}
- Mounting cost and area can be cut in half

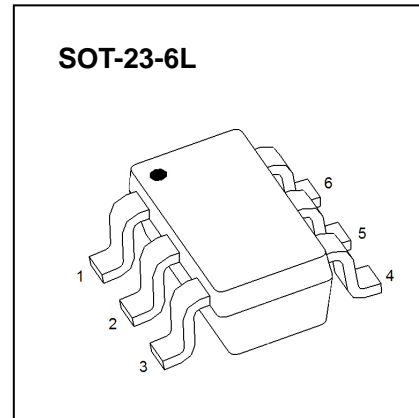

MARKING



PIN1

EQUIVALENT CIRCUIT

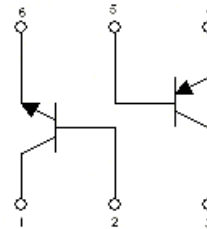

Tr1 NPN and Tr2 PNP Absolute Maximum Ratings ($T_a=25^\circ\text{C}$)

Symbol	Parameter	Value		Unit
		NPN	PNP	
V_{CB0}	Collector-Base Voltage	40	-40	V
V_{CEX}	Collector-Emitter Voltage	40	-40	V
V_{CE0}	Collector-Emitter Voltage	30	-30	V
V_{EB0}	Emitter-Base Voltage	7	-7	V
I_C	Collector Current- Continuous	1.5	-1.5	A
I_{CM}	Collector Current- Peak	5	-5	A
P_C	Collector Power Dissipation	350	350	mW
$R_{\theta JA}$	Thermal Resistance from Junction to Ambient	357	357	$^\circ\text{C}/\text{W}$
T_J	Junction Temperature	150		$^\circ\text{C}$
T_{stg}	Storage Temperature	-55~+150		$^\circ\text{C}$

ELECTRICAL CHARACTERISTICS

Tr1 NPN ($T_a=25^\circ\text{C}$ unless otherwise specified)

Parameter	Symbol	Test conditions	Min	Typ	Max	Unit
Collector-base breakdown voltage	$V_{(BR)CBO}$	$I_C=100\mu\text{A}$, $I_E=0$	40			V
Collector-emitter breakdown voltage	$V_{(BR)CEO}^*$	$I_C=10\text{mA}$, $I_B=0$	30			V
Collector-emitter breakdown voltage	$V_{(BR)CEX}$	$I_C=1\mu\text{A}$, $V_{BE(off)}=-0.5\text{V}$	40			V
Emitter-base breakdown voltage	$V_{(BR)EBO}$	$I_E=100\mu\text{A}$, $I_C=0$	7			V
Collector cut-off current	I_{CBO}	$V_{CB}=32\text{V}$, $I_E=0$			20	nA
Collector cut-off current	I_{CER}	$V_{CE}=16\text{V}$, $R_s\leq 1\text{k}\Omega$			20	nA
Emitter cut-off current	I_{EBO}	$V_{EB}=6\text{V}$, $I_C=0$			20	nA
DC current gain	h_{FE}^*	$V_{CE}=2\text{V}$, $I_C=100\text{mA}$	180		500	
Collector-emitter saturation voltage	$V_{CE(sat)}^*$	$I_C=750\text{mA}$, $I_B=15\text{mA}$			0.375	V
Base-emitter saturation voltage	$V_{BE(sat)}^*$				1.2	V

Tr2 PNP ($T_a=25^\circ\text{C}$ unless otherwise specified)

Parameter	Symbol	Test conditions	Min	Typ	Max	Unit
Collector-base breakdown voltage	$V_{(BR)CBO}$	$I_C=-100\mu\text{A}$, $I_E=0$	-40			V
Collector-emitter breakdown voltage	$V_{(BR)CEO}^*$	$I_C=-10\text{mA}$, $I_B=0$	-30			V
Collector-emitter breakdown voltage	$V_{(BR)CEX}$	$I_C=-1\mu\text{A}$, $V_{BE(off)}=0.5\text{V}$	-40			V
Emitter-base breakdown voltage	$V_{(BR)EBO}$	$I_E=-100\mu\text{A}$, $I_C=0$	-7			V
Collector cut-off current	I_{CBO}	$V_{CB}=-32\text{V}$, $I_E=0$			-20	nA
Collector cut-off current	I_{CER}	$V_{CE}=-16\text{V}$, $R_s\leq 1\text{k}\Omega$			-20	nA
Emitter cut-off current	I_{EBO}	$V_{EB}=-6\text{V}$, $I_C=0$			-20	nA
DC current gain	h_{FE}^*	$V_{CE}=-2\text{V}$, $I_C=-100\text{mA}$	180		500	
Collector-emitter saturation voltage	$V_{CE(sat)}^*$	$I_C=-750\text{mA}$, $I_B=-15\text{mA}$			-0.375	V
Base-emitter saturation voltage	$V_{BE(sat)}^*$				-1.2	V

*Pulse Test : Pulse Width $\leq 300\mu\text{s}$, Duty Cycles $\leq 2\%$.

Typical Characteristics

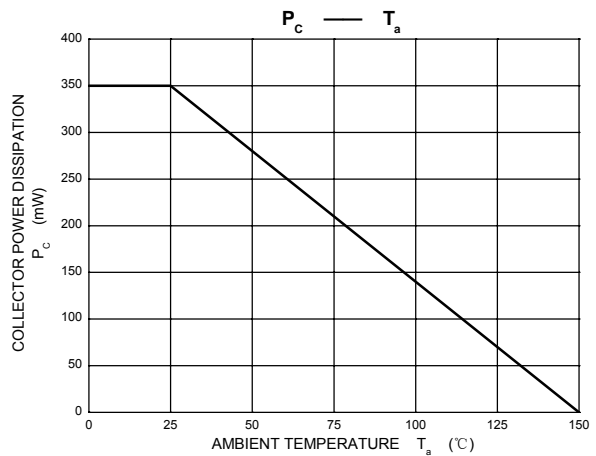
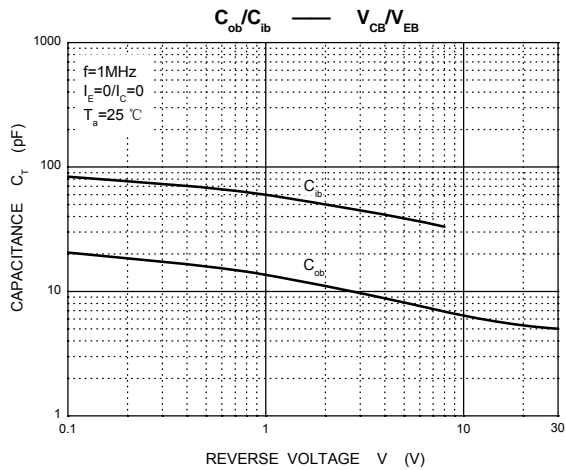
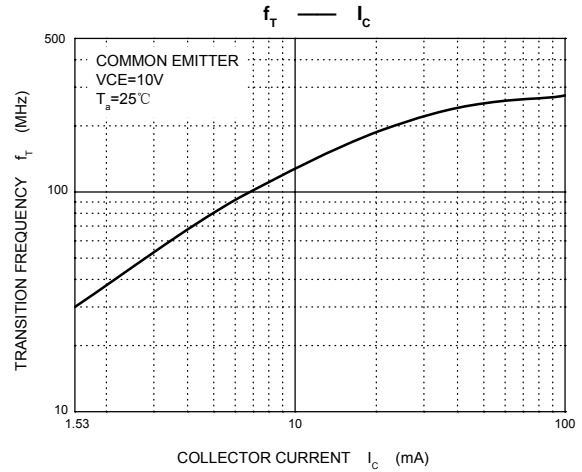
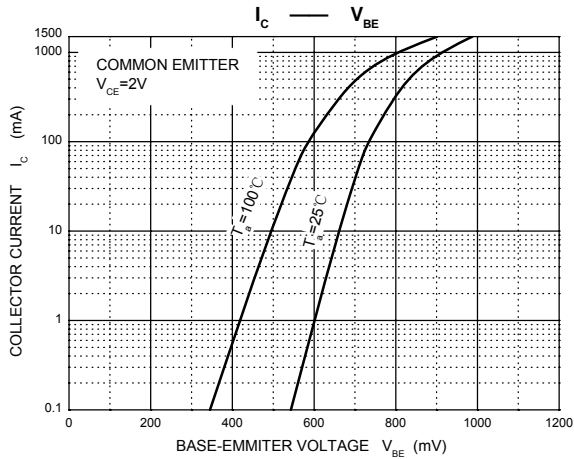
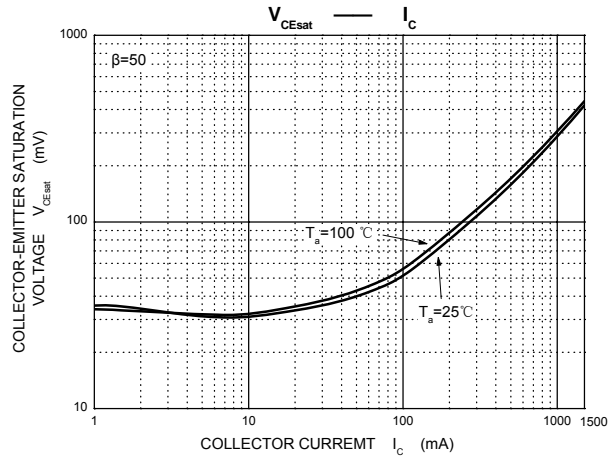
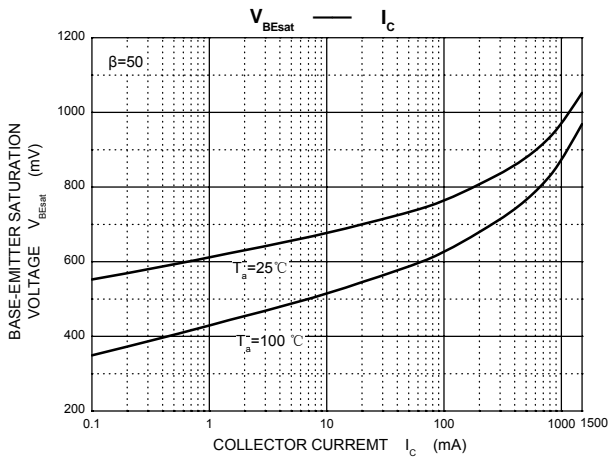
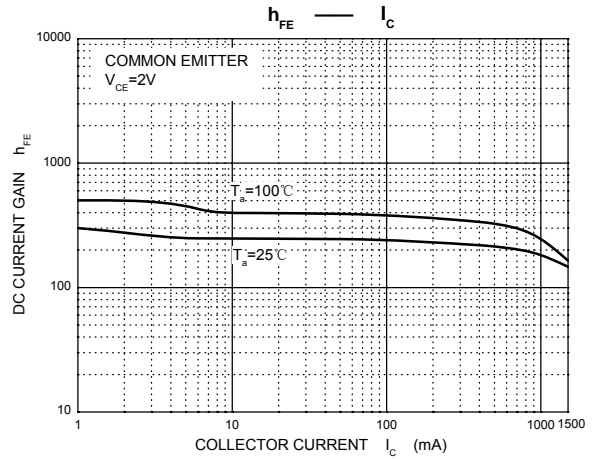
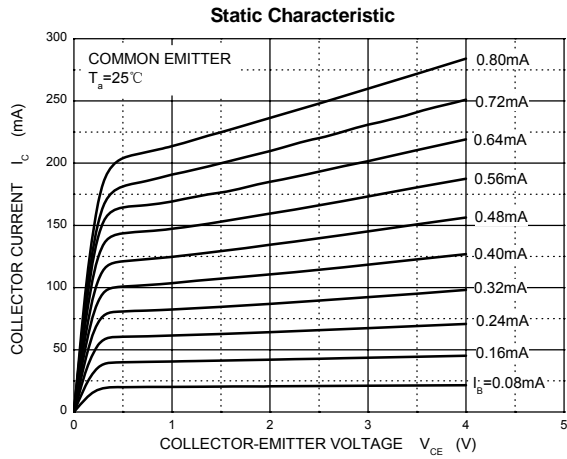

Typical Characteristics

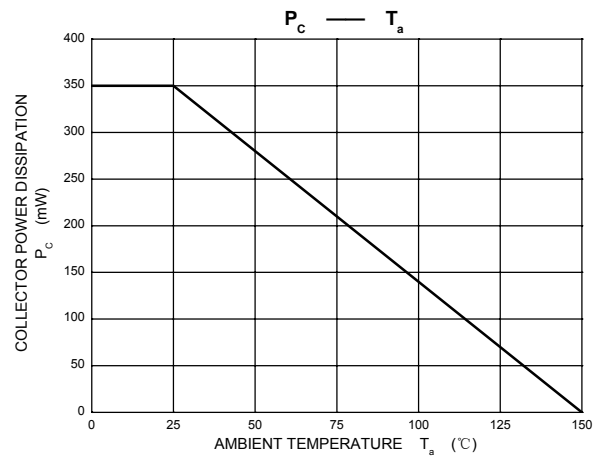
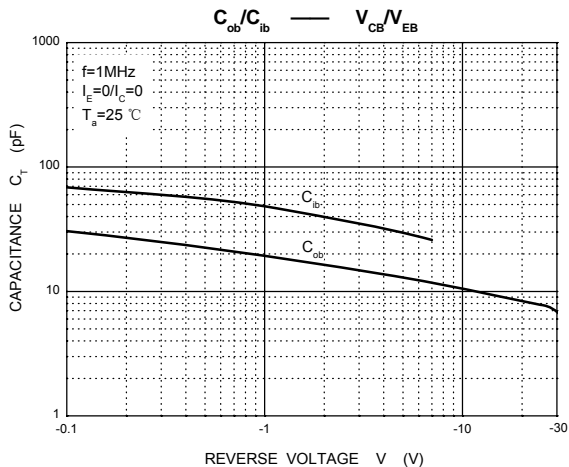
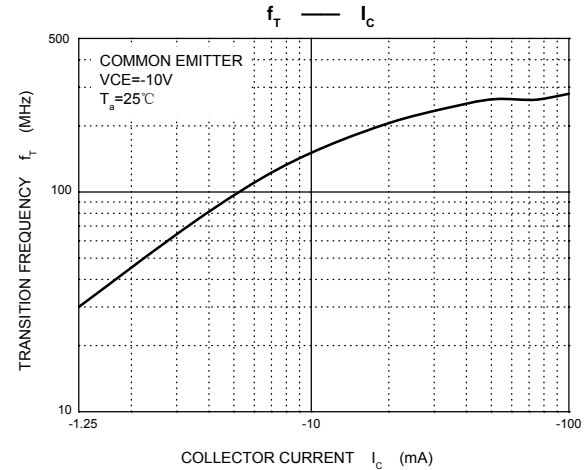
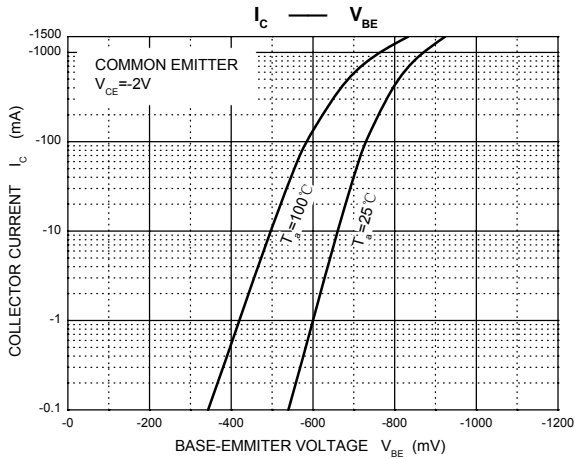
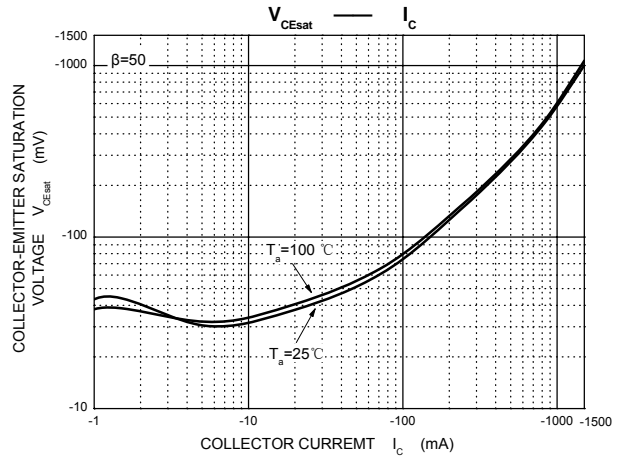
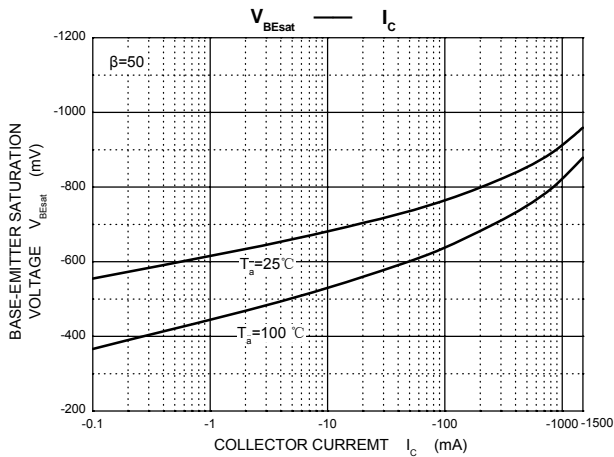
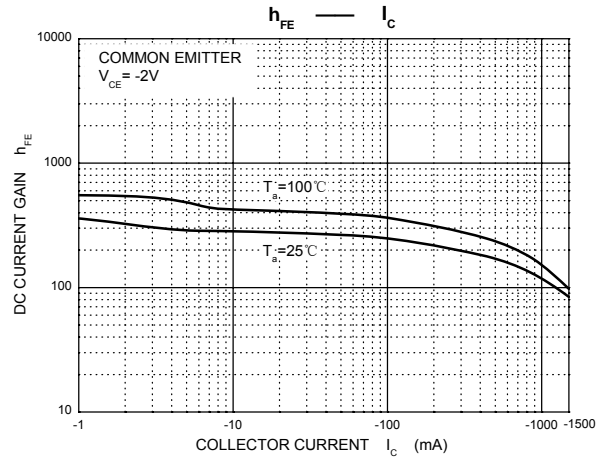
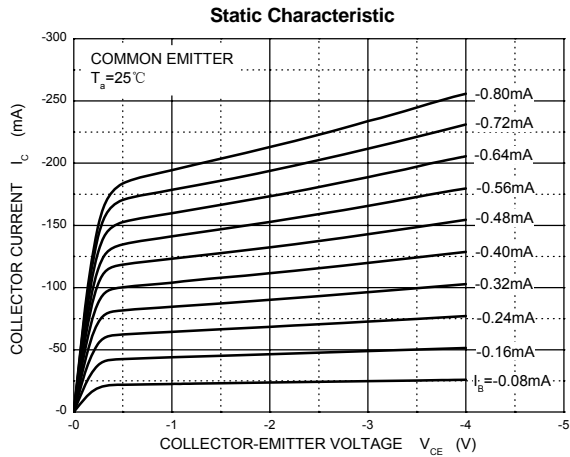

SOT-23-6L Package Outline Dimensions

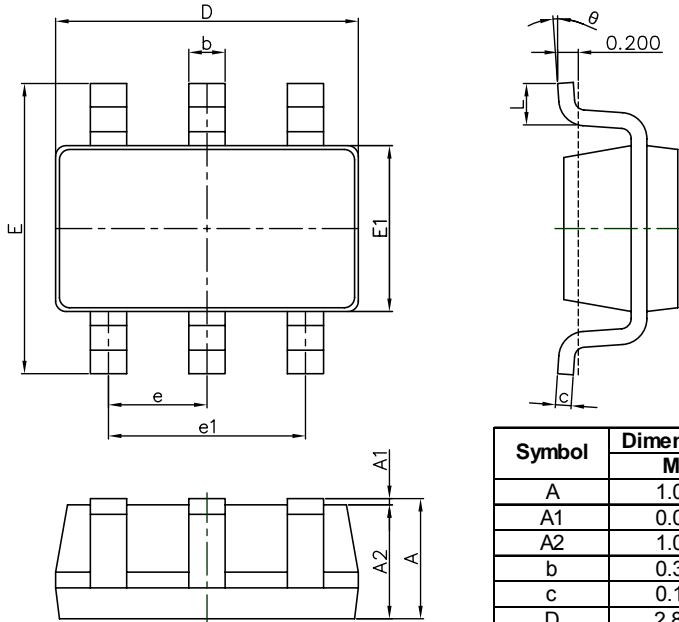

Symbol	Dimensions In Millimeters		Dimensions In Inches	
	Min.	Max.	Min.	Max.
A	1.050	1.250	0.041	0.049
A1	0.000	0.100	0.000	0.004
A2	1.050	1.150	0.041	0.045
b	0.300	0.500	0.012	0.020
c	0.100	0.200	0.004	0.008
D	2.820	3.020	0.111	0.119
E1	1.500	1.700	0.059	0.067
E	2.650	2.950	0.104	0.116
e	0.950(BSC)		0.037(BSC)	
e1	1.800	2.000	0.071	0.079
L	0.300	0.600	0.012	0.024
θ	0°	8°	0°	8°

SOT-23-6L Suggested Pad Layout

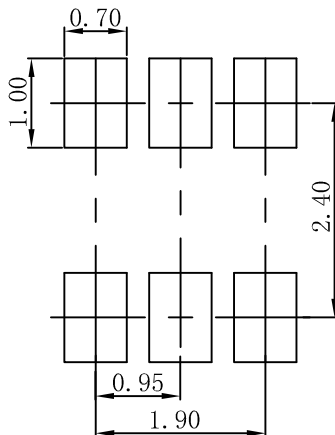

Note:

1. Controlling dimension: in millimeters.
2. General tolerance: ± 0.05mm.
3. The pad layout is for reference purposes only.