

61083- AA B C D E G W V FF

AA	NO. OF POSITIONS
02	2X10
04	2X20
06	2X30
08	2X40
10	2X50
12	2X60
14	2X70
16	2X80
18	2X90
20	2X100

NOTE 10

G	DATE CODE
/	STANDARD, NOT PRINT D/C
P	PRINT DATE CODE

W	TRANSPORT CODE
/	NOT MANDATORY
W	FOR OCEAN SHIPPING

V	MANDATORY CODE
/	STANDARD, NOT MANDATORY P/N
V	ONLY FOR DEDICATED CUSTOMER
H	ONLY FOR DEDICATED CUSTOMER
L	ONLY FOR DEDICATED CUSTOMER

E	PACKAGING
0	TUBE WITHOUT METAL CAP
2	T&R WITH METAL CAP
9	TUBE WITH METAL CAP
6	T&R WITH KAPTON TAPE
7	T&R WITH PLASTIC CAP
Q	T&R WITHOUTL CAP

NOTE 10
NOTE 10
NOTE 11
NOTE 10

D	PEG
0	YES
2	NO

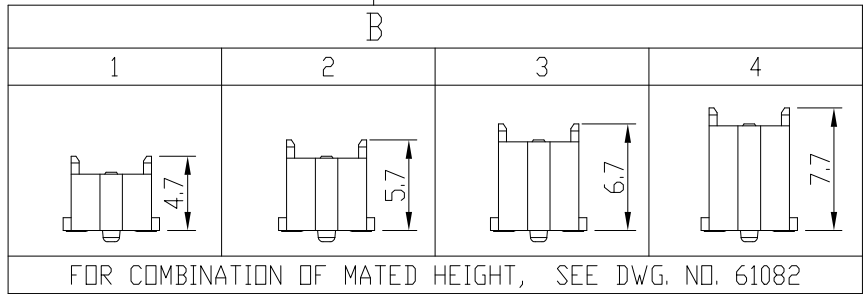

C	PLATING	FF
0	GOLD 0.2um MIN ON CONTACT AREA ; TIN LEAD 2.5um MIN ON SOLDER TAIL NICKEL UNDERPLATE OVERALL 1.27um MIN	NONE
1	GOLD FLASH (0.065um MIN) OVER PALLADIUM-NICKEL 0.69um MIN ON CONTACT AREA ; TIN LEAD 2.5um MIN ON SOLDER TAIL NICKEL UNDERPLATE OVERALL 1.27um.	NONE
4	GOLD 0.2um MIN ON CONTACT AREA ; PURE MATT TIN 2.5um MIN ON SOLDER TAIL; NICKEL UNDERPLATE OVERALL 1.27um. (LEADFREE PLATING)	LF
5	GOLD 0.38um MIN ON CONTACT AREA ; MATT PURE TIN 2.5um MIN ON SOLDER TAIL; NICKEL UNDERPLATE OVERALL 1.27um MIN (LEADFREE PLATING)	LF
6	GOLD FLASH (0.065um MIN) OVER PALLADIUM-NICKEL 0.69um MIN ON CONTACT AREA ; PURE MATT TIN 2.5um MIN ON SOLDER TAIL NICKEL UNDERPLATE OVERALL 1.27um. (LEADFREE PLATING)	LF
7	GOLD 0.76um MIN ON CONTACT AREA ; PURE MATT TIN 2.5um MIN ON SOLDER TAIL; NICKEL UNDERPLATE OVERALL 1.27um. (LEADFREE PLATING)	LF
9	GOLD 0.2um MIN ON CONTACT AREA ; GOLD 0.05um MIN ON SOLDER TAIL NICKEL UNDERPLATE OVERALL 1.27um. (LEADFREE PLATING)	LF

- NOTE:
- MATERIAL:
HOUSING: G.F. LCP, NATURAL, UL94-V0
TERMINAL: BRASS
 - PLATING: AS SHOWN IN TABLE.
 - SEE GS-12-547 FOR PRODUCT SPEC.
 - PACKAGING OPTION 2: NOT ALL SIZES ARE AVAILABLE. CHECK WITH FACTORY.
 - THIS PRODUCT MEETS THE EUROPEAN UNION DIRECTIVES AND OTHER COUNTRY REGULATIONS AS DESCRIBED IN GS-22-008.
 - THE HOUSING WILL WITHSTAND EXPOSURE UP TO 260~ PEAK TEMPERATURE FOR 30 SECONDS IN A CONVECTION, INFRA-RED OR VAPOR PHASE REFLOW OVEN.
 - PLATING OPTION "4" IS LEADFREE ALTERNATIVE FOR OPTION "0", AND OPTION "6" IS LEADFREE ALTERNATIVE FOR OPTION "1".
 - HIGH PRECISION COPLANARITY IS AVAILABLE FOR 2X80 TO 2X100 PDS, ALL HEIGHTS. PLS REFER TO PRINT 10069525.
 - THE P/N 61083-***** OR 61083-*****LF NOT PRINT DATE CODE.
THE P/N 61083-*****P OR 61083-*****PLF NEED PRINT DATE CODE.
 - POSITION 2X10 TYPE ONLY APPLY TO PLUG 1 AND PLUG 3.
PACKAGING WITH METAL CAP AND PLASTIC CAP DOES NOT APPLY TO 2X10 POSITION.
 - KAPTON TAPE ONLY APPLY TO POSITION 2X10~2X20.

mat'l. code		surface		tolerance		projection		product family	
		ISO 1302		ISO 406 ISO		ISO 1101		BERGSTAK HPL545	
ltr	ecn no	dr	date	tolerances unless otherwise specified		mm		title	
AP	ELX-N-33922	Bob	2019-07-05	angles	linear	mm		PLUG ASSY	
AR	ELX-N-34967	Bob	2019-09-26	0±3'		scale 1:1		BERGSTAK 0.8MM	
AK	ELX-N-26185	Bob	2017-02-17	dr	GuoMin Sun	2014-10-21		dwg no	
AL	ELX-N-26381	Bob	2017-03-17	engr	Bob Gu	2019-09-26		sheet 1 of 6	
AM	ELX-N-30296	Bob	2018-05-28	chr	LQ Lei	2019-09-26		size	
AN	ELX-N-30741	Bob	2018-11-22	appd	Tim Yao	2019-09-26		61083	
sheet	revision	AL	AM	AN	AP	AR		type Product Customer Drawing	
index	sheet	1~6	1~6	1	1			A3	

PRODUCT NO.	NO. OF POSITION	DIMENSION		
		A	B	C
61083-021***	2X10	7.2	13.8	12.2
61083-041***	2X20	15.2	21.8	20.2
61083-061***	2X30	23.2	29.8	28.2
61083-081***	2X40	31.2	37.8	36.2
61083-101***	2X50	39.2	45.8	44.2
61083-121***	2X60	47.2	53.8	52.2
61083-141***	2X70	55.2	61.8	60.2
61083-161***	2X80	63.2	69.8	68.2
61083-181***	2X90	71.2	77.8	76.2
61083-201***	2X100	79.2	85.8	84.2

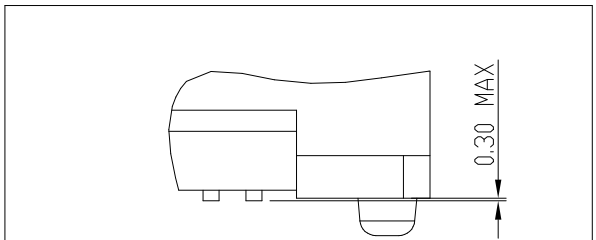
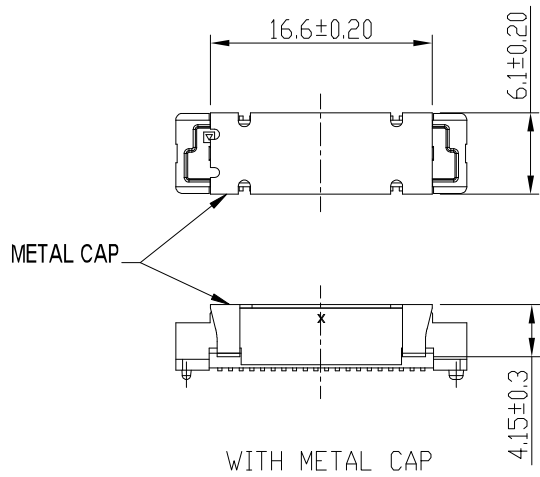

COPLANARITY OF TAIL:
 0.10 MAX. APPLIED TO 2X10 TO 2X70 PDS
 0.13 MAX. APPLIED TO 2X80 TO 2X100 PDS

DETAIL A
 SCALE 10:1

DATE CODE: XXXXXX

DAY(01~31)
 MONTH(01~12)
 YEAR(00~99)

DETAIL AA

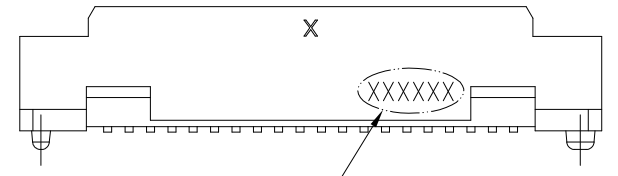

PLUG 1

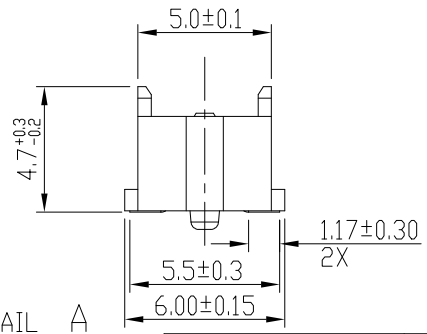
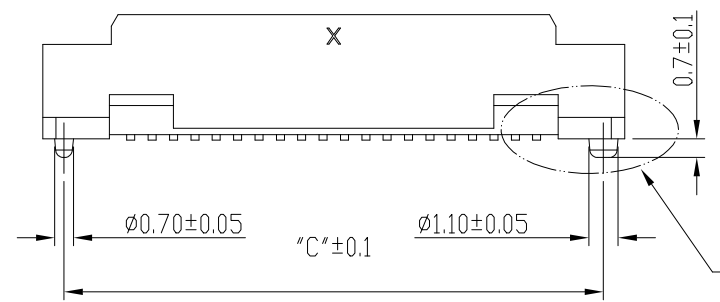
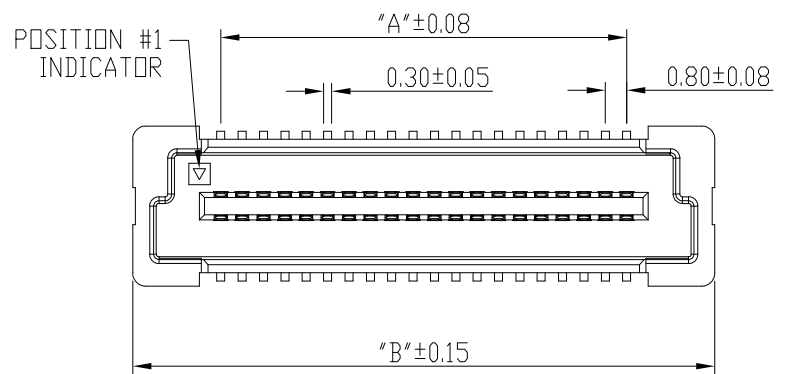

mat'l. code		surface	tolerance	projection	product family
		ISO 1302 ✓	ISO 406 ISO 1101	ISO 1101	BERGSTAK HPL545
ltr	ecn no	dr	date	tolerances unless otherwise specified	title
AR				.0±.2	PLUG ASSY
				angles linear .00±.15	BERGSTAK 0.8MM
				0°±3' .000±.10	scale 1:1
		dr	GuoMin Sun	2014-10-21	Amphenol FCI
		engr	Bob Gu	2019-09-26	dwg no
		chr	LQ Lei	2019-09-26	sheet2 of 6
		appd	Tim Yao	2019-09-26	size
sheet index	revision	AR			61083
	sheet	1			A3
					type Product Customer Drawing

Amphenol FCI

© 2016 AFCI

PRODUCT NO.	NO. OF POSITION	DIMENSION		
		A	B	C
61083-042***	2X20	15.2	21.8	20.2
61083-062***	2X30	23.2	29.8	28.2
61083-082***	2X40	31.2	37.8	36.2
61083-102***	2X50	39.2	45.8	44.2
61083-122***	2X60	47.2	53.8	52.2
61083-142***	2X70	55.2	61.8	60.2
61083-162***	2X80	63.2	69.8	68.2
61083-182***	2X90	71.2	77.8	76.2
61083-202***	2X100	79.2	85.8	84.2

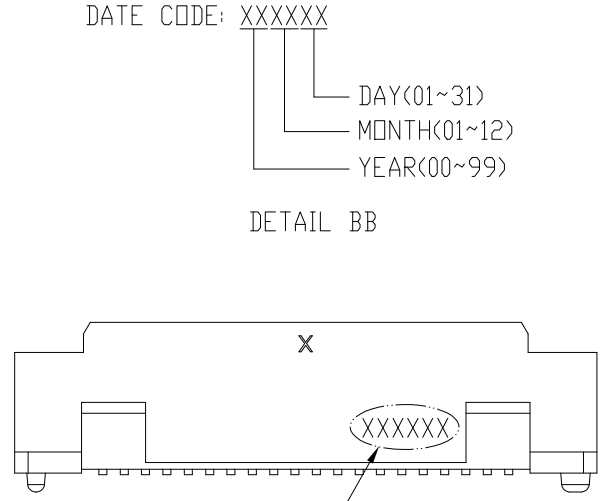
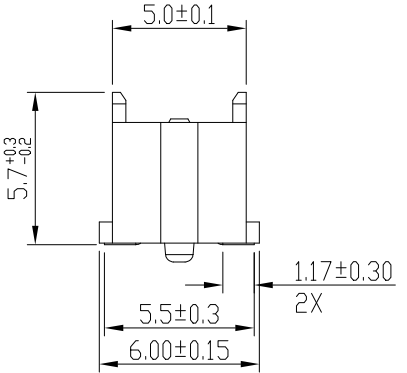
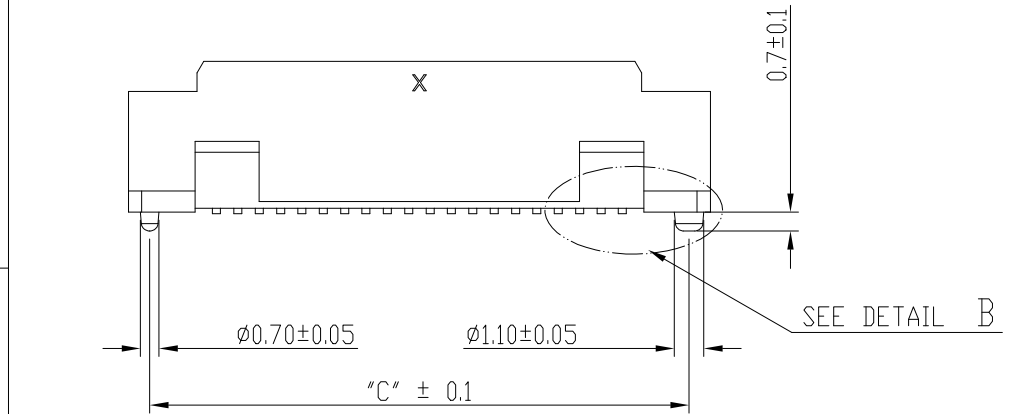
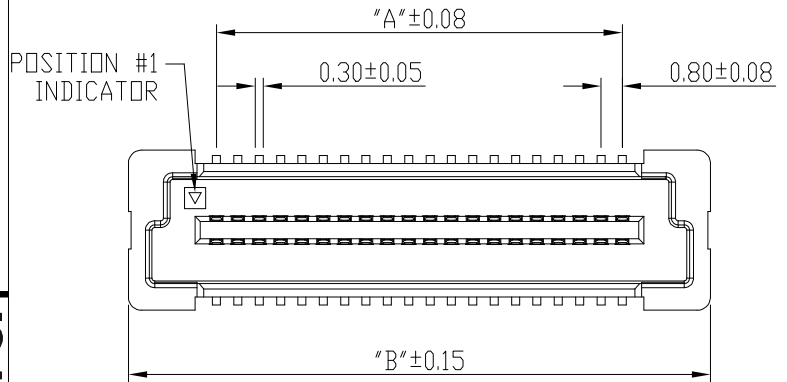
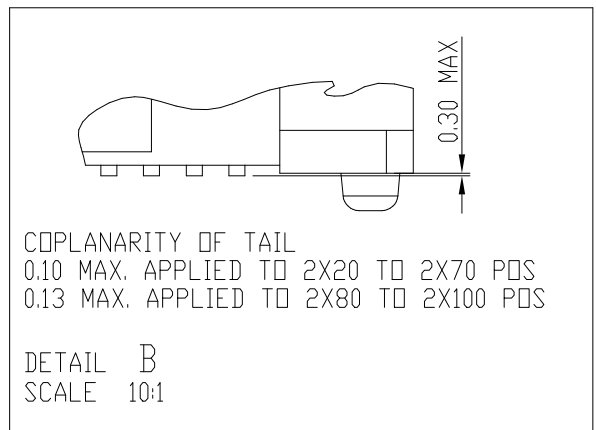
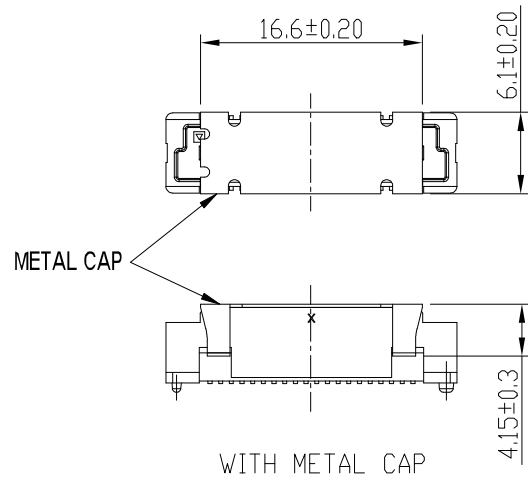

DATE CODE: XXXXXX
 DAY(01~31)
 MONTH(01~12)
 YEAR(00~99)
 DETAIL BB

PLUG 2

mat'l. code		surface ISO 1302 ✓	tolerance ISO 406 ISO 1101	projection	product family BERGSTAK HPL545
ltr	ecn no	dr	date	tolerances unless otherwise specified	title
AR				angles linear	PLUG ASSY BERGSTAK 0.8MM
				0°±3'	mm
				.0±.2	scale 1:1
				.00±.15	Amphenol FCI
				.000±.10	dwg no 61083 sheet 3 of 6 size A3
		dr	GuoMin Sun 2014-10-21		type Product Customer Drawing
		engr	Bob Gu 2019-09-26		
		chr	LQ Lei 2019-09-26		
		appd	Tim Yao 2019-09-26		
sheet index	revision sheet	AR	1		

Amphenol FCI

© 2016 AFCI

PRODUCT NO.	NO. OF POSITION	DIMENSION		
		A	B	C
61083-023***	2X10	7.2	13.8	12.2
61083-043***	2X20	15.2	21.8	20.2
61083-063***	2X30	23.2	29.8	28.2
61083-083***	2X40	31.2	37.8	36.2
61083-103***	2X50	39.2	45.8	44.2
61083-123***	2X60	47.2	53.8	52.2
61083-143***	2X70	55.2	61.8	60.2
61083-163***	2X80	63.2	69.8	68.2
61083-183***	2X90	71.2	77.8	76.2
61083-203***	2X100	79.2	85.8	84.2

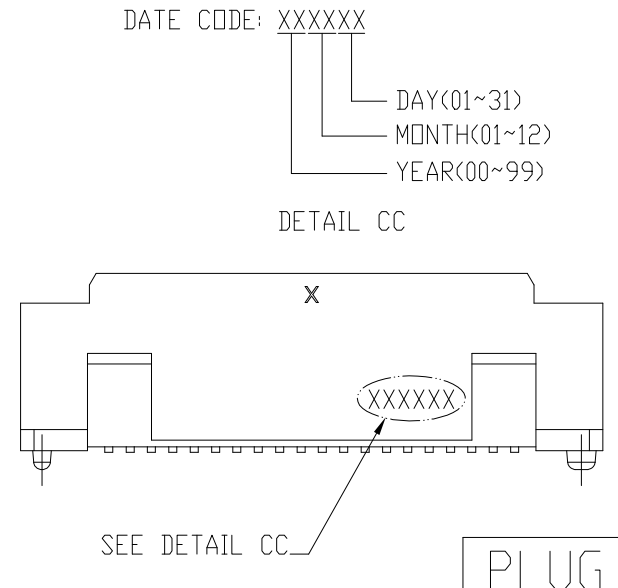
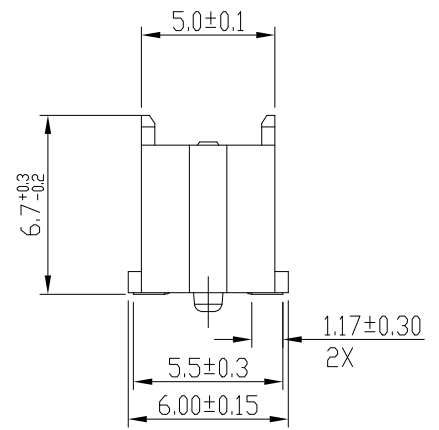
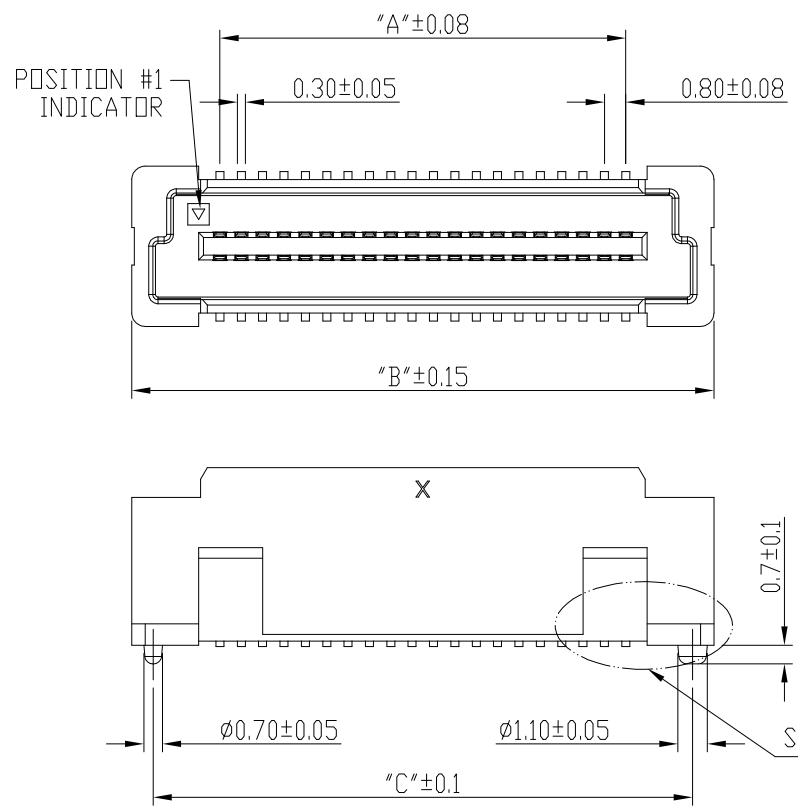
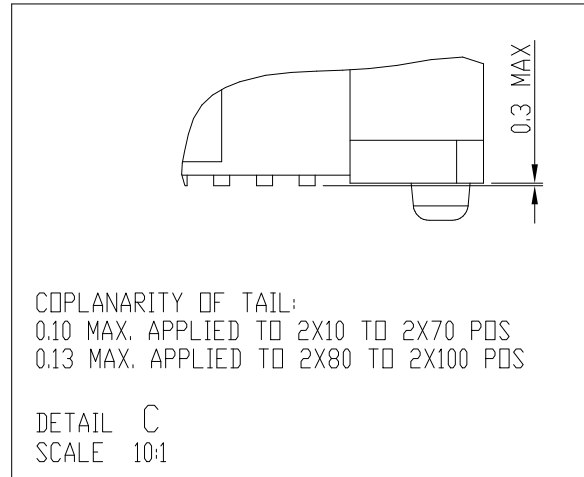
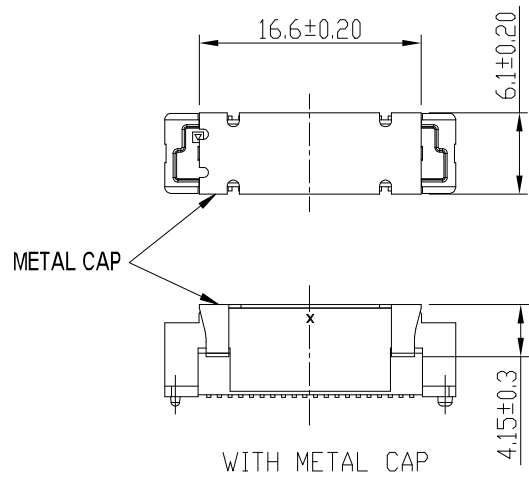

PLUG 3

mat'l. code		surface ISO 1302 ✓	tolerance ISO 406 ISO 1101	projection	product family BERGSTAK HPL545
ltr	ecn no	dr	date	tolerances unless otherwise specified	title
AR				linear .0±.2 .00±.15 .000±.10	PLUG ASSY BERGSTAK 0.8MM
				0°±3'	scale 1:1
		dr	GuoMin Sun	2014-10-21	Amphenol FCI
		engr	Bob Gu	2019-09-26	dwg no 61083 sheet 4 of 6 size A3
		chr	LQ Lei	2019-09-26	type Product Customer Drawing
		appd	Tim Yao	2019-09-26	
sheet index	revision sheet	AR	1		

© 2016 AFCl
 Amphenol FCI
 D

PRODUCT NO.	NO. OF POSITION	DIMENSION		
		A	B	C
61083-044***	2X20	15.2	21.8	20.2
61083-064***	2X30	23.2	29.8	28.2
61083-084***	2X40	31.2	37.8	36.2
61083-104***	2X50	39.2	45.8	44.2
61083-124***	2X60	47.2	53.8	52.2
61083-144***	2X70	55.2	61.8	60.2
61083-164***	2X80	63.2	69.8	68.2
61083-184***	2X90	71.2	77.8	76.2
61083-204***	2X100	79.2	85.8	84.2

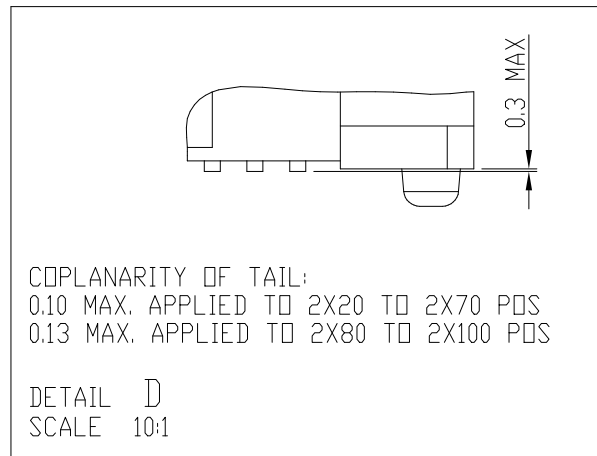
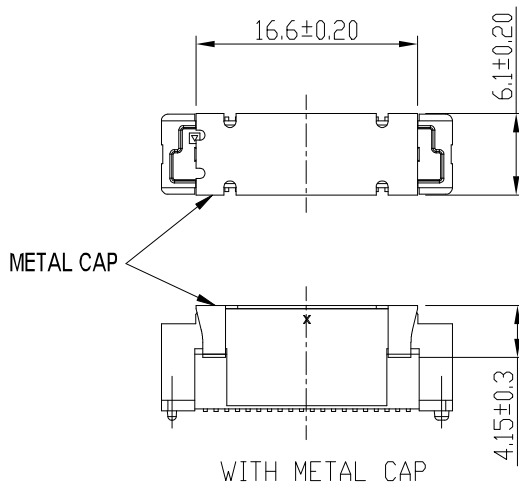
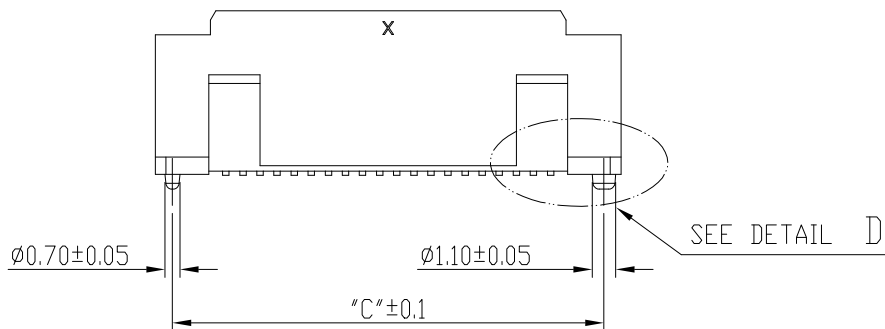
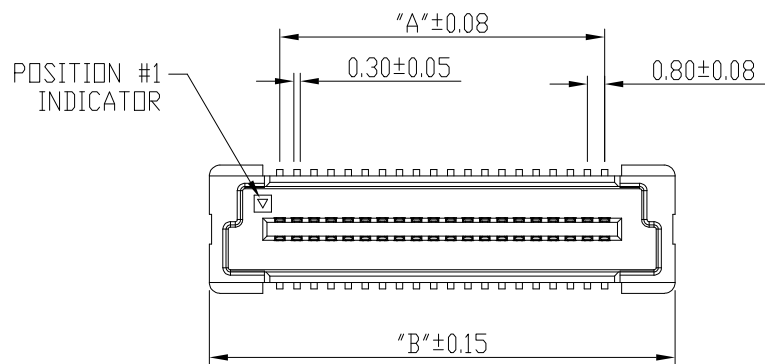

DATE CODE: XXXXXX
 DAY(01~31)
 MONTH(01~12)
 YEAR(00~99)

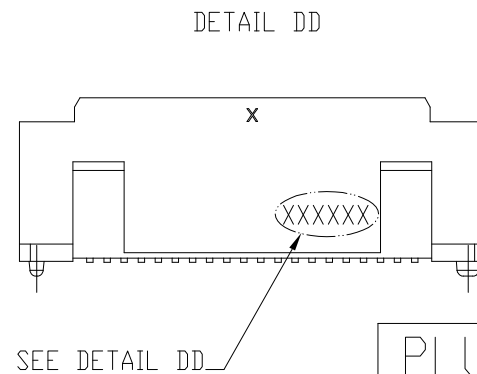
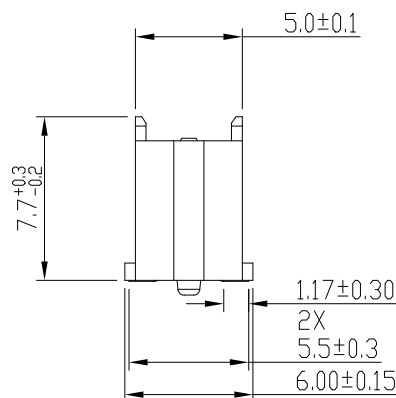

mat'l. code		surface ISO 1302 ✓	tolerance ISO 406 ISO 1101	projection	product family BERGSTAK HPL545
ltr	ecn no	dr	date	tolerances unless otherwise specified	title
AR				angles linear	PLUG ASSY BERGSTAK 0.8MM
				0°±3'	mm
				.0±.2	scale 1:1
				.00±.15	Amphenol FCI
				.000±.10	dwg no 61083 sheet 5 of 6 size A3
		dr	GuoMin Sun 2014-10-21		type Product Customer Drawing
		engr	Bob Gu 2019-09-26		
		chr	LQ Lei 2019-09-26		
		appd	Tim Yao 2019-09-26		
sheet index	revision sheet	AR	1		

Amphenol FCI

© 2016 AFCI

FOR PLUG 1/2/3/4

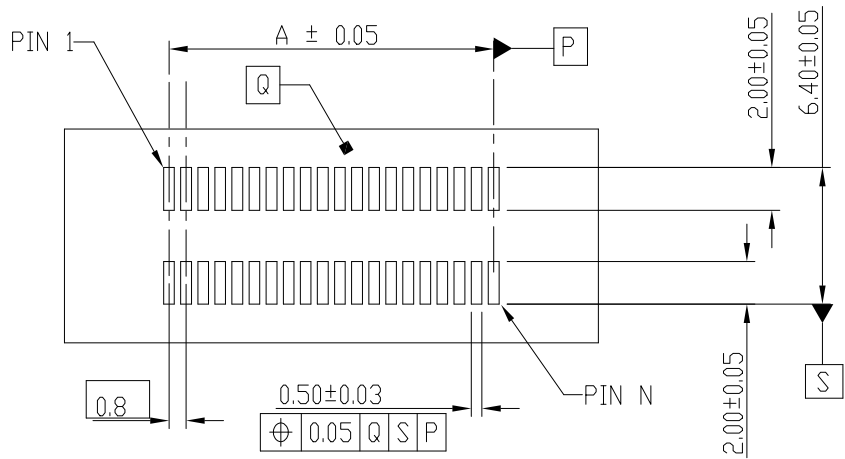

RECOMMENDED PCB LAYOUT WITHOUT PEG FOR
 NO. OF PDS 2X10, 2X20, 2X30, 2X40, 2X50 2X60

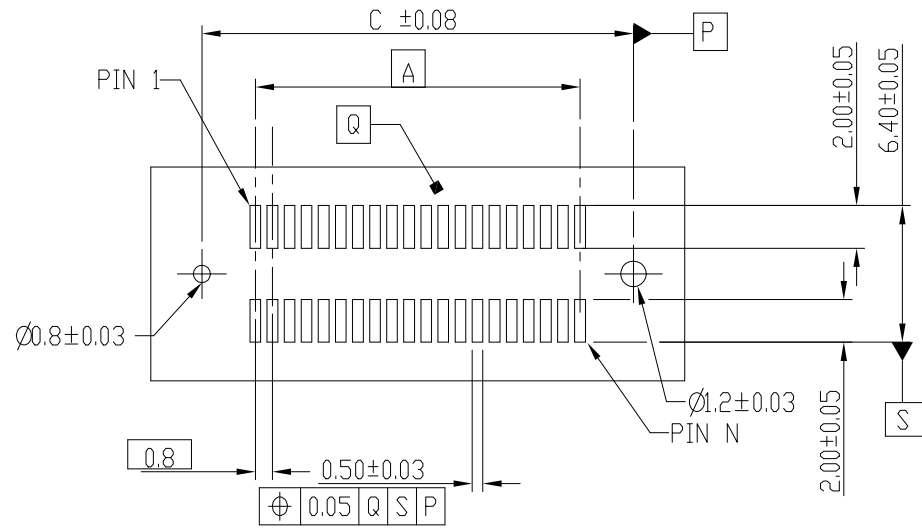

RECOMMENDED PCB LAYOUT WITH PEG FOR
 NO. OF PDS 2X70, 2X80, 2X90, 2X100

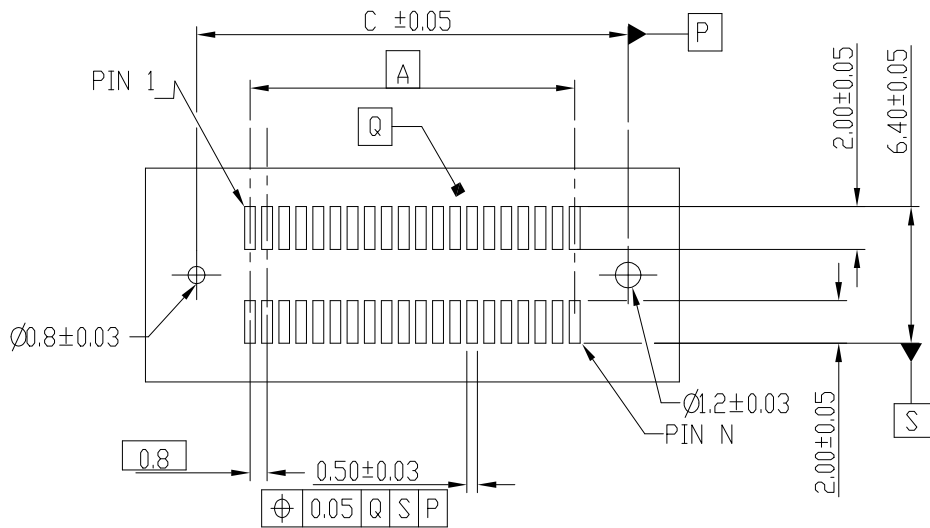

RECOMMENDED PCB LAYOUT WITH PEG FOR
 NO. OF PDS 2X10, 2X20, 2X30, 2X40, 2X50 2X60

mat'l. code		surface	tolerance	projection	product family
		ISO 1302 ✓	ISO 406 ISO 1101		BERGSTAK HPL545
ltr	ecn no	dr	date	tolerances unless otherwise specified	title
AR				linear	PLUG ASSY BERGSTAK 0.8MM
				angles	mm
				0°±3'	scale 1:1
		dr	GuoMin Sun	2014-10-21	dwg no 61083 sheet 6 of 6 size A3
		engr	Bob Gu	2019-09-26	
		chr	LQ Lei	2019-09-26	
		appd	Tim Yao	2019-09-26	
sheet index	revision	AR			type Product Customer Drawing
	sheet	1			