

High Efficiency, Synchronous Boost Charger for 2 cell Li-ion Battery

1 DESCRIPTION

The SC8921 is a highly integrated switch-mode boost charger for two cell Li-ion battery applications. It is able to step up 4.5V~5.5V input voltage to up to 16V, and provide battery charge management functions including trickle charge, constant current charge, constant voltage charge, charge termination and charging status indication.

The SC8921 supports flexible charge current option, and the user can program the current freely through external resistor for different applications. With the charger management function, the IC can be used to charge 2 cell Li-ion battery.

The SC8921 supports 2A input current limit, input under voltage and over voltage protections, internal cycle by cycle current limit, battery short circuit protection, and output over voltage protection. It also offers charging safety timer and over temperature protection to ensure safety under different abnormal conditions.

The SC8921 is available in ESOP8L package.

2 FEATURES

- Integrated Synchronous Boost Charger
- Charging Management (Trickle Charge / Constant Current Charge / Constant Voltage Charge / Charge Termination)
- Programmable Constant Charge Current
- Selectable Constant Voltage
- Charge Status Indication
- Charge Safety Timer
- 2A Input Current Limit
- Adaptive Input Current Limit
- Input Under Voltage and Over Voltage Protection
- Battery Short Circuit Protection
- Short circuit protection for VBAT output
- Thermal Shutdown

3 APPLICATIONS

- Blue tooth speaker charger
- E-cigarette charger
- E-joy charger
- LI-ion battery charger
- POS machine

4 DEVICE INFORMATION

Part Number	Package	Dimension
SC8921SDER	ESOP8L	5 mm x 6 mm x 1.5 mm

5 Typical Application Circuit

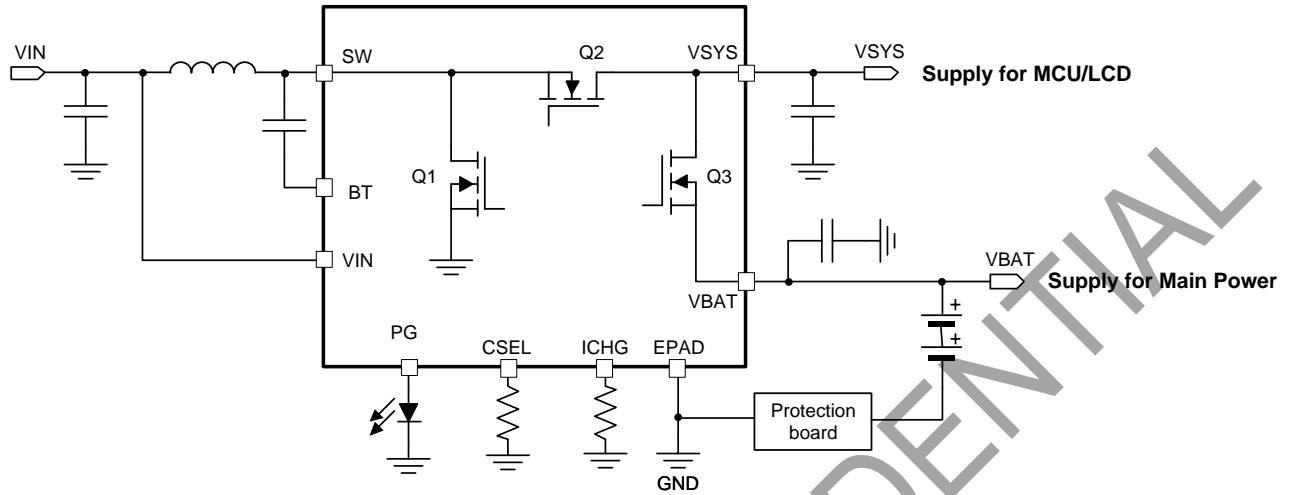

6 Selection Guide

Part Number	VIN range	Max. VBAT	Integrated Power Switch	Max. Input current limit	VINREG	Power path management	NTC	Cell Balance	Pin #
SC8921	4.5V~5.5V	13.2V	Yes	2A	4.5V	No	No	NO	8 pin ESOP8L

7 Terminal Configurations and Functions

ESOP8L Top View –SC8921

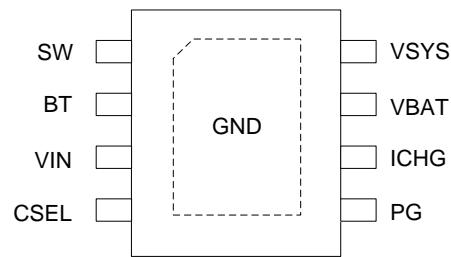

I/O			DESCRIPTION
SC8921	NAME		
1	SW	IO	Switching node of the boost converter. Connect to external inductor.
2	BT	IO	Bootstrap pin. Connect a 100nF ceramic capacitor between BT pin and SW pin to provide bias voltage for internal driver circuit.
3	VIN	I	Input of the boost charger
4	CSEL	I	Connect a resistor to GND to select the battery termination voltage target
5	PG	O	Charging status indication pin. Connect an LED from PG pin and GND pin. It is internally pulled high to indicate the charge in process. When the battery is fully charged, it outputs high impedance and the LED is off.
6	ICHG	I	Connect a resistor to GND to program the battery constant charging current.
7	VBAT	O	Output of the boost charger to charge the battery cells.
8	VSYS	O	Output of the boost converter. This pin can provide power for the system operation.
9	GND	IO	Thermal pad Ground. Connect power ground with it.

8 Specifications

8.1 Absolute Maximum Ratings

Over operating free-air temperature range (unless otherwise noted)⁽¹⁾

		Min.	Max.	Unit
Voltage ⁽²⁾	VIN, SW, VSYS	-0.3	16	V
	VBAT	-0.3	14	V
	BT	-0.3	21	V
	CSEL, PG, ICHG	-0.3	5.5	V
T _J	Operating junction temperature	-40	150	°C
T _{stg}	Storage temperature	-65	150	°C

(1) Stresses beyond those listed under absolute maximum ratings may cause permanent damage to the device.

(2) All voltages are with respect to network ground terminal.

8.2 Thermal Information

THERMAL RESISTANCE ⁽¹⁾		ESOP8L	Unit
θ _{JA}	Junction to ambient thermal resistance	30	°C/W
θ _{JC}	Junction to case resistance	3	°C/W

(1) Measured on JESD51-7, 4-layer PCB.

8.3 ESD Ratings

		Min.	Max.	Unit
V _{ESD} ⁽¹⁾	Human-body Model (HBM) ⁽²⁾	-2	2	kV
	Charged-device Model (CDM) ⁽³⁾	-750	750	V

(1) Electrostatic discharge (ESD) to measure device sensitivity and immunity to damage caused by assembly line electrostatic discharges into the device.

(2) Level listed above is the passing level per ANSI, ESDA, and JEDEC JS-001. JEDEC document JEP155 states that 500-V HBM allows safe manufacturing with a standard ESD control process.

(3) Level listed above is the passing level per EIA-JEDEC JESD22-C101. JEDEC document JEP157 states that 250-V CDM allows safe manufacturing with a standard ESD control process.

8.4 Recommended Operation Conditions

		Min.	Typ.	Max.	Unit
V _{IN}	VIN voltage range	4.5	5	5.5	V
L	Inductor	1	2.2	3.3	μH
C _{IN}	VIN capacitor	4.7			μF
C _{VSYS}	VSYS capacitor	22			μF
C _{VBAT}	VBAT capacitor	4.7			μF



T_A	Operating ambient temperature	-40		85	°C
T_J	Operating junction temperature	-40		125	°C

SOUTHCHIP CONFIDENTIAL

9 Function Block Diagram

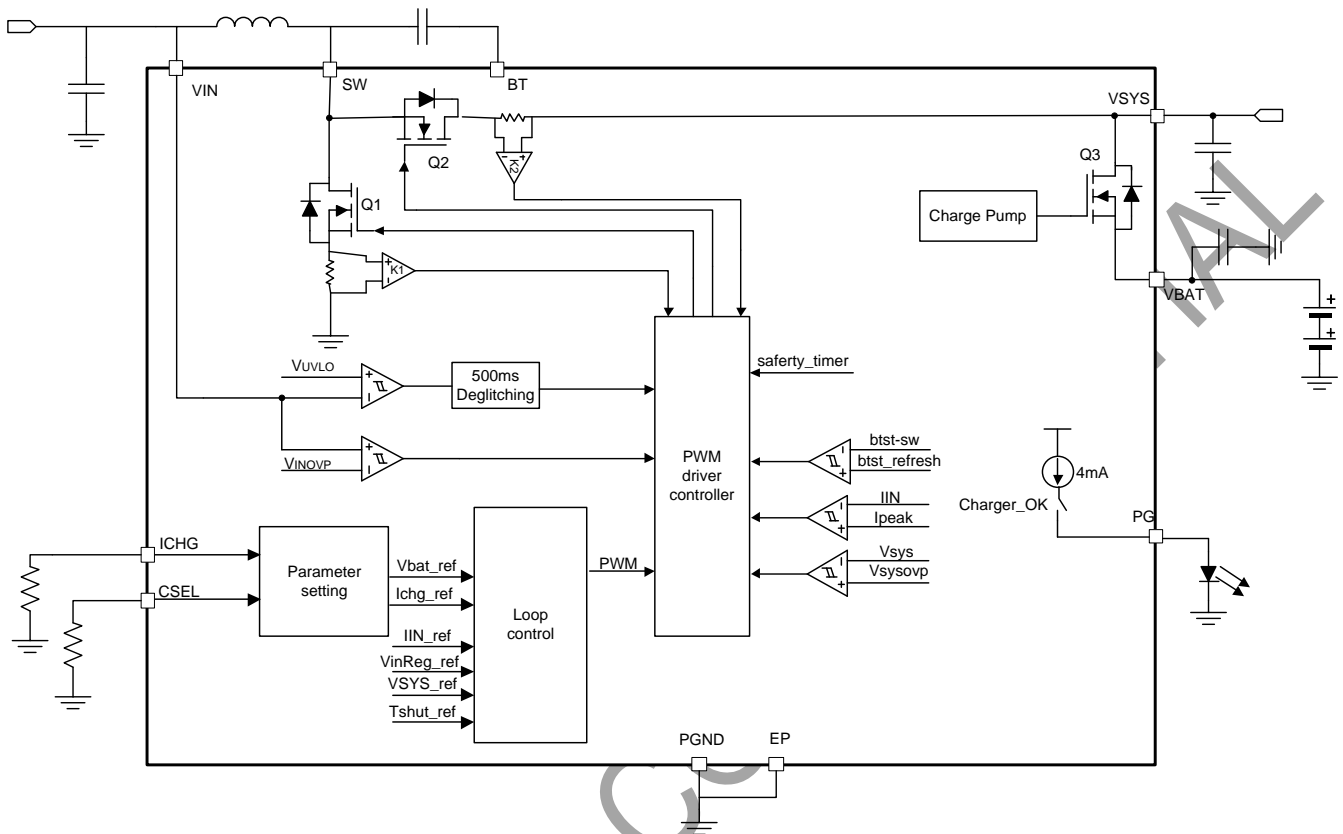

**10 Electrical Characteristics (TBD)**

Parameter	Description	Test condition	Min.	Typ.	Max.	Unit
Supply and power path						
V _{IN}	Operating input voltage		4.5	5	5.9	V
V _{UVLO}	Under voltage lockout threshold		3	3.2	3.4	V
	Hysteresis		450	550	650	mV
V _{SYS}	V _{SYS} regulation voltage	V _{BUS} = 5V, V _{BAT} = 5V	5.9	6.2	6.5	V
V _{REF}	Reference voltage		1.176	1.2	1.224	V
I _{Q_VIN}	Quiescent current into VIN pin	Mode pin= float, V _{IN} = 5V, V _{SYS} = V _{BAT} = 8V, non-switching		1.8	3	mA
I _{Q_VBAT}	Quiescent current into VBAT pin	Mode pin= float, V _{IN} = open, V _{BAT} = 8V		2.2		uA
Power stage						
R _{dson_Q1}	Rdson resistance of Q1	V _{IN} =5V, V _{SYS} =V _{BAT} =8V	37	47	57	mΩ
R _{dson_Q2}	Rdson resistance of Q2	V _{IN} =5V, V _{SYS} =V _{BAT} =8V	32	42	52	mΩ
R _{dson_Q3}	Rdson resistance of Q3	V _{IN} =5V, V _{SYS} =V _{BAT} =8V	43	53	63	mΩ
f _{sw}	Switching frequency		680	800	920	KHz
T _{max_ON}	Maximum on time			5		us
Charger Function						
I _{CHG}	Constant charging current accuracy	R _{ICHG} = 12 kΩ	0.95	1	1.05	A
I _{TRK}	Trickle charging current accuracy	R _{ICHG} = 12 kΩ, V _{BAT} = 5V	0.1	0.2	0.4	A
I _{TRK_INT}	Internal trickle charge current	R _{ICHG} = 0 Ω, V _{BAT} = 5V	0.15	0.3	0.5	A
I _{TERM_INT}	Internal termination charge current	R _{ICHG} = 0 Ω	0.075	0.15	0.1725	A
V _{BAT_TRGT}	V _{BAT} target voltage	CSEL = open	8.358	8.4	8.442	V
		CSEL = 300 kΩ	8.514	8.6	8.686	V



		CSEL = 150 kΩ	8.613	8.7	8.787	V
		CSEL = 80 kΩ	8.712	8.8	8.888	V
V _{BAT_TERM}	Termination threshold over VBAT target	Rising edge	96%	98%	99%	
V _{BAT_RECH}	Recharge threshold over VBAT_TRGT	Falling edge	94.05%	95.8%	96.91%	
V _{TRK_CH}	Trickle charge threshold for 2S cell	Rising edge	5.690	5.8	5.92	V
		Hysteresis	300	400	500	mV
V _{INREG}	VINREG voltage		4.365	4.5	4.635	V
I _{PG}	Source current at PG pin	VPG = 3V	3	4	5	mA
T _{term_dly}	Termination delay time			1		s
T _{rech_dly}	Recharge delay time			10		ms
T _{safe_timer}	safety timer			24		h
Charger Function						
I _{LIM_IN}	Input current limit		1.75	1.85	1.95	A
I _{LIM_PK}	Peak current limit		5.5	6.5	8	A
V _{IN_OVP}	Input over voltage protection	Rising edge	5.8	6	6.2	V
		Hysteresis	0.24	0.3	0.36	V
V _{SYS_OVP}	VSYS over voltage protection	Rising edge, over VSYS target		110%		
		Hysteresis, over VSYS target		5%		
V _{BAT_SC}	VBAT short circuit protection threshold	Falling edge	1.8	2	2.2	V
		Hysteresis	160	200	240	mV
I _{Q3_SC}	Q3 regulation current for short circuit protection		120	200	280	mA
LOGIC						



V_{IL}	MODE and IIN input low voltage threshold		0.4		0.7	V
V_{IH}	IIN input high voltage threshold		0.9		1.2	V
Start up						
t_D	Input delay time				5	us
$t_{DEBOUNCE}$	Input debounce time	From VIN power up to starting switching			500	ms
t_{SS}	Softstart time	VREF ramp up rate			2	ms
THERMAL						
T_{SD}	Thermal shutdown temperature	Rising		165		°C
		Hysteresis		30		°C



11 Feature Description

11.1 UVLO and Shutdown Mode

The SC8921 is in shutdown when its input voltage is lower than V_{UVLO} threshold. After V_{IN} rises above the UVLO threshold, the IC exits shut down mode to charge the battery cells.

When in shutdown mode, the Q3 will be turned off to disconnect the system from battery. In this case, there is still a path from battery to V_{SYS} pin through the body diode of Q3, and V_{SYS} equals to $V_{BAT} - 0.7V$.

11.2 Soft-Start

After V_{IN} rises above UVLO threshold, there is a 500ms debounce time before the IC starts operation.

After the 500ms debounce time expires, the IC starts switching and charges the battery in CC mode or CV mode. If V_{BAT} is higher than V_{TRK} , Q3 is turned on 4ms before debounce time expires. If V_{BAT} is lower than V_{TRK} , the IC ramps up the V_{SYS} to 6.2V first, then it turns on Q3 in linear mode to work in trickle charging mode.

The SC8921 integrates an internal soft start circuit which controls the ramp up of the V_{SYS} output and the charge current to the battery cells, preventing inrush current during start-up.

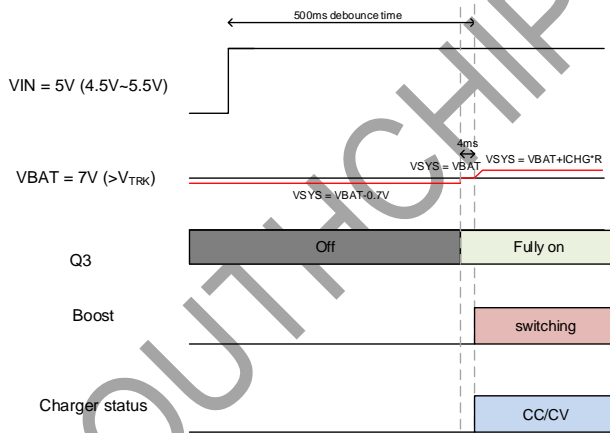

Figure 1 Startup with $V_{BAT} > V_{TRK}$

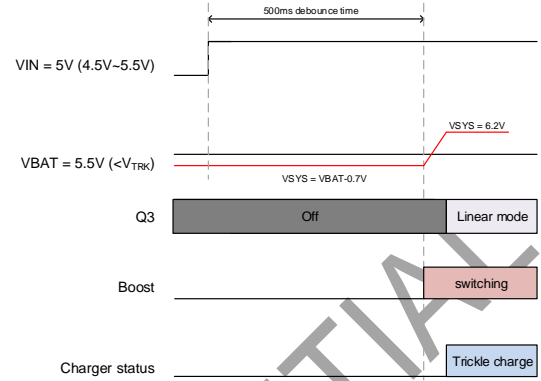

Figure 2 Startup with $V_{BAT} < V_{TRK}$

11.3 Charge management

The SC8921 provides charge management functions for 2 cell Li-ion battery. The typical charge profile is shown in Figure 3.

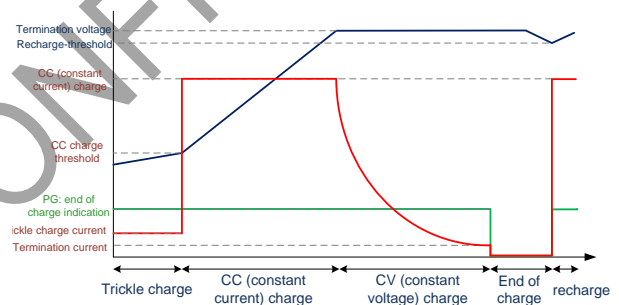

Figure 3 Typical charge profile

11.3.1 Trickle Charge

When V_{BAT} is lower than V_{TRK} , the SC8921 charges the battery cells in trickle charge mode. In this mode, V_{SYS} is regulated at 6.2V, and Q3 is turned on and works in linear mode. The charge current through Q3 is monitored and regulated at 1/5 of the constant charge current programmed by ICHG pin.

If the 1/5 of the CC current is higher than 300mA, the trickle charge current will be clamped to 300mA.

11.3.2 Constant Current (CC) Charge

When V_{BAT} voltage is charged above V_{TRK} , the SC8921 enters into constant charge (CC) mode. In this mode, the Q3 is fully turned on. The IC monitors Q3 current, and controls the switching duty cycle so to regulate the Q3 current at the CC value programmed by ICHG pin.



11.3.3 Constant Voltage (CV) Charge

The SC8921 operates in constant voltage (CV) mode after VBAT exceeds 98% of the termination voltage target VBAT_TRGT. In CV mode, the Q3 is kept fully on, and the battery voltage is regulated at VBAT_TRGT. The charge current automatically drops until the battery is fully charged.

The battery target voltage can be configured through an external resistor at CSEL pin. Below table shows the relationship between the CSEL resistor value and the VBAT target voltage.

Table 1 CSEL pin to set VBAT target voltage

CSEL Resistor Value	VBAT target voltage
Open	8.4V
300 kΩ	8.6V
150 kΩ	8.7V
80 kΩ	8.8V

11.3.4 Charge Termination / End of Charge

When below two conditions are valid, the SC8921 recognizes the battery cells are fully charged:

- 1) Termination voltage: the VBAT voltage is higher than 98% of VBAT_TRGT
- 2) Termination current: the Q3 Charge current is lower than 150mA.
- 3) Termination voltage and current condition lasts longer than 1s.

When above conditions are met together, the SC8921 outputs high impedance at PG pin, so the LED connected at PG pin is off, indicating the end of charge (EOC).

When charger enters into termination, the IC stops switching and turns off Q3, so to terminate the battery charging. Meantime, VSYS equals to VBAT – 0.7V.

11.3.5 Recharge

After EOC, the SC8921 still monitors VBAT voltage. Once it detects the battery voltage falls below 96% of VBAT_TRGT, it turns on Q3 and returns to CC mode again.

11.4 Charging Status Indication

When the SC8921 charges the battery in trickle charge/CC charge/CV charge mode, the PG pin outputs logic high, so the LED connected at PG pin is turned on, indicating the charging is in process.

After the EOC conditions are met, the PG pin outputs high impedance, indicating the battery cells are fully charged.

If the battery voltage drops below the recharge threshold V_{RECH}, the LED will be turned on again.

11.5 Constant Charge Current Programming

The constant charge current can be programmed by ICHG pin as below:

$$ICC = K \cdot \frac{VREF}{RICHG}$$

Where,

ICC is the programmed constant charge current

VREF is the internal reference voltage, 1.2V

RICHG is the resistor connected at ICHG pin

K = 10 000

If the ICHG pin is short to ground, the constant charge current is infinite. In this case, the SC8921 relies on input current limit and the internal peak current limit to protect the chip. Accordingly, the IC will set the trickle charge and charge termination current to 200mA internally.

11.6 Charge Current Sense

The ICHG pin's voltage is proportional to the Q3 current, so the user can monitor the Q3 charge current through ICHG pin as below:

$$IQ3 = K \cdot \frac{VICHG}{RICHG}$$

Where,

IQ3 is the charge current through Q3

VICHG is the voltage at ICHG pin

RICHG is the resistor connected at ICHG pin

K = 10000

11.7 Input Current Limit

The SC8921 supports input current limit function, and the limit current is 2A.



The IC monitors the input current during operation. Once it detects the input current exceeds the limit, the IC reduces the switching cycle and regulates the input current at 2A.

11.8 Adaptive Input Current Limit

Besides the input current limit function, the SC8921 supports adaptive input current limit function (VINREG function) to prevent overloading the input adapter.

If the external adapter has smaller current capability than the current the IC draws, IC's VIN voltage will be pulled down. Once the IC detects VIN is pulled below 4.5V, which indicates the adapter can't supply required current, the IC reduces the input current automatically. The input current is reduced to a value which can keep adapter output at 4.5V, so to prevent the adapter from overloading further. This is called adaptive input current limit function or VINREG function.

If the adapter current capability is very low, the IC may enter into burst mode during this operation.

11.9 Input Over Voltage Protection

Besides under voltage protection, the SC8921 also supports input over voltage protection. Once the IC detects the input voltage is higher than 6V, it stops switching, turns off Q3 and PG flashes at 1Hz. After the input voltage drops below the threshold, it resumes the normal operation.

11.10 VSYS Over Voltage Protection

The SC8921 monitors VSYS voltage during the operation. Once it detects the VSYS is higher 110% of the target

voltage, over voltage protection will be triggered, and the IC stops switching at once. After the VSYS voltage drops below 104% of the target, it resumes switching. Q3 status will not be affected by VSYS OVP.

11.11 VBAT Short Circuit Protection

Once the IC detects the VBAT voltage drops below 2V, the short circuit protection is triggered. The IC turns on Q3 in linear mode and regulates the short current to 200mA. Meantime, the IC regulates the VSYS at 6V.

After the short circuit fault is removed, the VBAT voltage is charged up. When VBAT voltage is higher than the short circuit threshold, the IC returns to normal operation.

11.12 Safety Timer

When the IC starts charging (VIN above VINREG threshold), a 24-hours safety timer is initiated. Once it detects EOC condition, the IC clears the timer, and it doesn't restart the timer unless recharge phase starts or VIN toggle happens.

If the charging cycle doesn't end when the timer expires, the IC will transition to shutdown mode. In this case, the IC will only restart the timer after VIN toggles.

11.13 Thermal shutdown

Once the SC8921 detects the junction temperature rises above 165°C, it shuts down the whole chip. When the temperature falls below 135°C, the chip is enabled again.

12 Application information (TBD)

12.1 Capacitor Selection

Since MLCC ceramic capacitor has good high frequency filtering with low ESR, above 22μF X5R or X7R capacitors with higher voltage rating than operating voltage with margin is recommended. For example, if the highest operating Vin voltage is 6V, select at least 10V capacitor and to secure enough margin, 16V voltage rating capacitor is recommended.

The high capacitance polymer capacitor or tantalum capacitor can be used for input and output, but capacitor voltage rating must be higher than the highest operating voltage with enough margin. The recommended capacitance polymer capacitor is at least 100uF to ensure loop stability. The high frequency characteristics of these capacitors are not as good as ceramic capacitor, so at least 10μF ceramic capacitor should be placed in parallel to reduce high frequency ripple.

12.2 Inductor Selection

1 μH to 3.3 μH inductor is recommended for loop stability. Choose the inductance to provide the desired ripple current. The current ripple is calculated as:

$$I_{ripple} = \frac{V_{IN} * (V_{OUT} - V_{IN})}{V_{OUT} * F_{SW} * L}$$

It is suggested to choose inductor ensure the ripple current to be about 40% of the average input current I_{IN} .

When selecting inductor, the inductor saturation current must be higher than the peak inductor current with enough margin (20% margin is recommended).

$$I_{peak} = I_{IN} + \frac{V_{IN} * (V_{OUT} - V_{IN})}{2 * F_{SW} * L * V_{OUT}}$$

Where I_{IN} is the input current, and can be calculated as:

$$I_{IN} = \frac{V_{OUT} * I_{chg}}{V_{IN} * \eta}$$

η is the efficiency of boost converter.

The inductor DC resistance value (DCR) affects the conduction loss of switching regulator, so low DCR

inductor is recommended especially for high power application. The conductor loss of inductor can be calculated roughly as:

$$PL_{DC} = I_{IN}^2 * DCR$$

I_{IN} is the average value of inductor current.

12.3 Layout Guide

1. The capacitors connected at VIN/VSYS/VBAT pins should be placed near the IC, and their ground connection to the ground pins should be as short as possible. Especially VSYS capacitor must be placed carefully to ensure better performance.

a. component(s) on schematic:

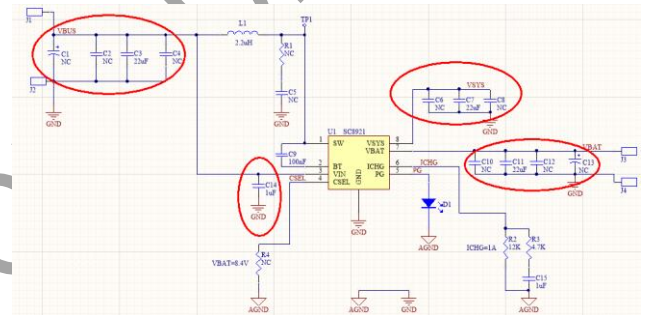

b. **Layout example:** put the input and output capacitors near IC especially the VIN 1uF capacitor. Connect the capacitors to each pin through vias and connect the capacitors to ground pins by the ground pour.

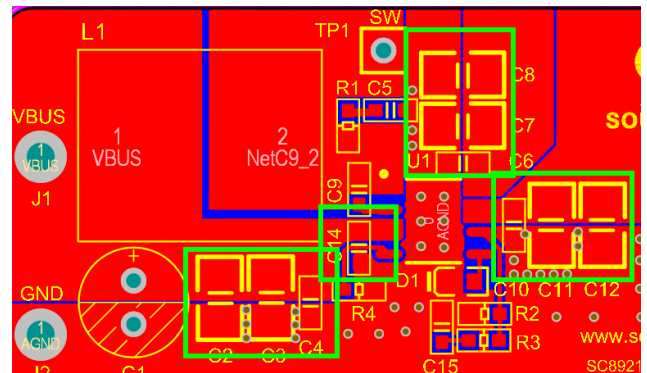

13 MECHANICAL DATA

ESOP8L

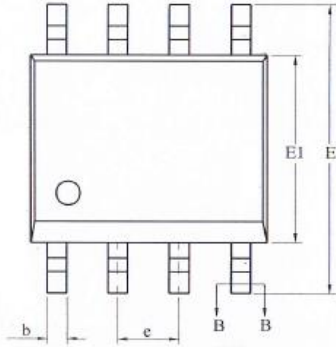

TOP VIEW

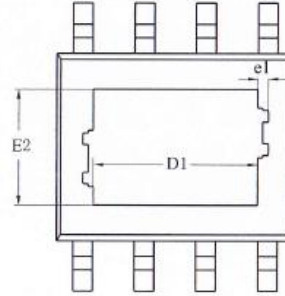

BOTTOM VIEW

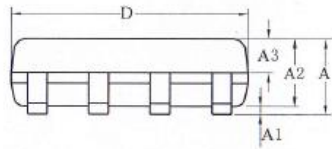

FRONT VIEW

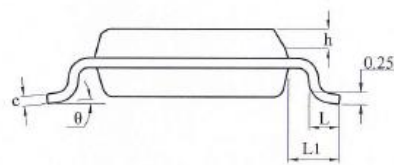

SIDE VIEW

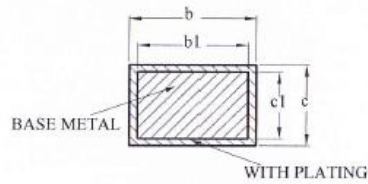

SECTION OF B-B

SYMBOL	MILLIMETER		
	MIN	NOM	MAX
A	—	—	1.65
A1	0.05	—	0.15
A2	1.30	1.40	1.50
A3	0.60	0.65	0.70
b	0.39	—	0.47
b1	0.38	0.41	0.44
c	0.20	—	0.24
c1	0.19	0.20	0.21
D	4.80	4.90	5.00
E	5.80	6.00	6.20
E1	3.80	3.90	4.00
e	1.27BSC		
h	0.25	—	0.50
L	0.50	0.60	0.80
L1	1.05REF		
θ	0	—	8°

Size (mm) L/P Size (mil)	D1	E2	e1
90*90	2.09REF	2.09REF	0.16REF
95*130	3.10REF	2.21REF	0.10REF