

- 주 기 -

1. 사용상 유해한 흠, BURR등이 없을 것.
2. CAV. No. 및 MARKING은 당사규격에 준하여 각인할 것.
3. 명시되지 않은 공차는 일반공차에 준할 것.
4. 지시하지 않은 R=0.30이하로 할 것.
5. PANEL 삽입/이탈력 기준
 - 1) PANEL 삽입력 : 12kg 이하
 - 2) PANEL 이탈력 : 15kg 이상
6. 적용 PANEL 사양(t)는 0.7~1.6mm 일 것.
7. 적용 PANEL HOLE SIZE :

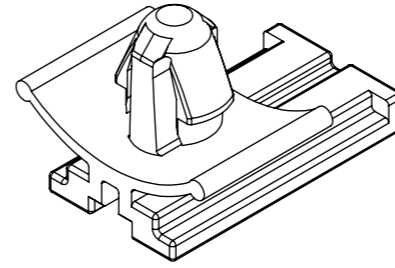

ISO-VIEW

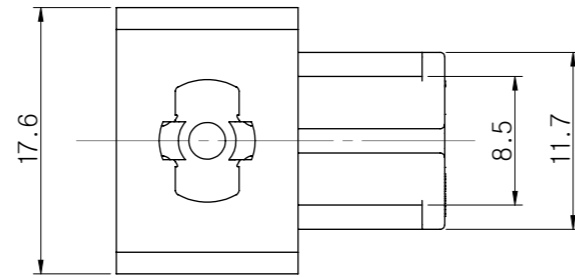
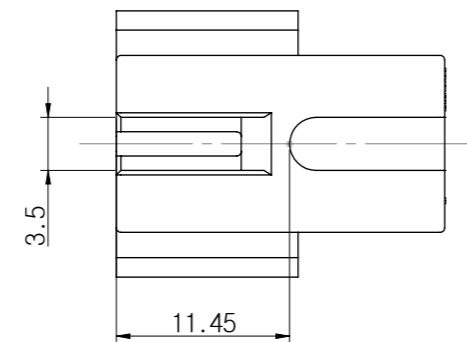
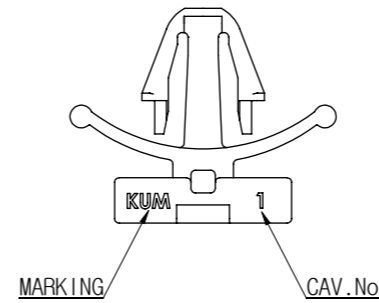
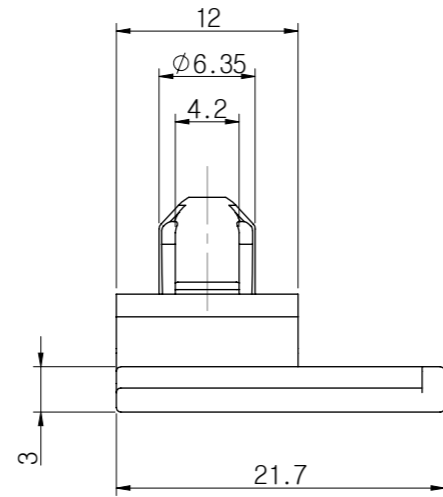
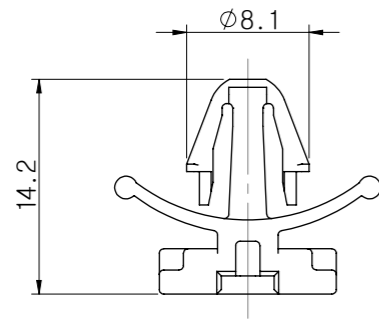
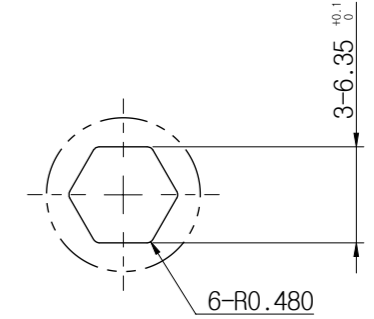

CJW	07.06.06	E007-0124	△	신 규	KHL
승인	DATE	NOTE No.	SYM	ALTERATION	담당

DRAWING NAME	CLIP NMWP-K10(B)
DRAWING No.	GC070-03020-C01

GENERAL TOLERANCE							
	10MAX	50MAX	100MAX	150MAX	200MAX	200VR	ANGLE
A	±0.2	±0.3	±0.5	±0.8	±1.0	±1.4	±30'

CLIP NMWP-K10(B)		GC070-03020		BLACK	PA66	
PART NAME		PART No.		COLOR	MATERIAL	
THIRD ANGLE PROJECTION	A	2/1	KHL	KHL	KNJ	CJW
	TOLERANCE	SCALE	DESIGN	DRAWN	CHECKED	APPROVED

KUM 케이유엠