

CJ78L Series Three Terminal Positive Regulators

1 Introduction

The CJ78L series is a three terminal positive voltage linear regulator with fixed voltage output. It has a wide input voltage range. The maximum input voltage can reach 30V (or 35V). At the same time, it can also provide 100mA output current under the condition of good heat dissipation. The CJ78L series adopts fixed voltage output without peripheral resistance, which improves the space utilization efficiency of printed circuit board (PCB). In addition, the CJ78L series also integrates internal current limit, short-circuit protection and thermal shutdown, so that it is basically not affected by overload. Therefore, the CJ78L series is widely used in various scenarios, such as card supervision, to eliminate the noise and distribution problems related to single point supervision. When used as a substitute for Zener-diode resistor combination, it can effectively improve the output impedance and reduce the bias current.

2 Applications

- TV Board
- Air Conditioner
- Vehicle Mounted Radar
- Air Conditioner
- Charging Device

3 Features

- Available Output Voltage:
5.0V, 6.0V, 8.0V, 9.0V, 12V and 15V
- Maximum Input Voltage:
30V for $V_{OUT} < 10V$
35V for $V_{OUT} > 10V$
- Maximum Output Current:
Exceed 100mA
- Output Tolerances:
 $\pm 3\%$ at $T_J = 25^\circ C$
 $\pm 5\%$ over the Operating T_J
- Build-in Current Limit
- Thermal Shutdown Protection
- Short Circuit Protection
- No External Components

4 Available Packages

PART NUMBER	PACKAGES
CJ78L Series	SOT-23-3L
	SOT-89-3L
	TO-92

Note: For more detailed packaging information, see the part *Pin Configuration and Function* and the part *Mechanical Information*.

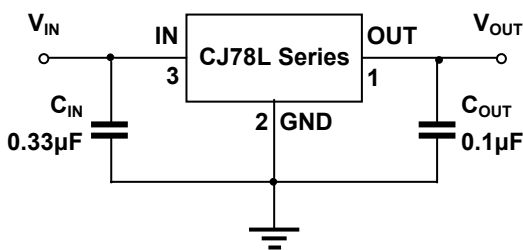

(1) Conventional Circuit

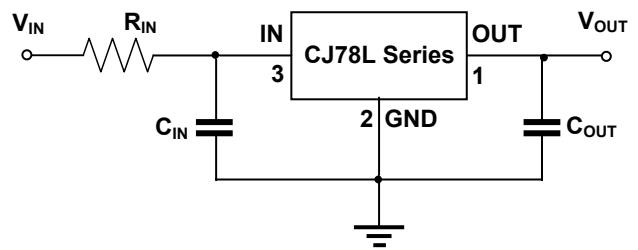

(2) Resistance are used at IN

Figure 2-1. Typical Application Circuit

5 Orderable Information

MODEL	DEVICE	PACKAGE	OP T _J	ECO PLAN	MSL	PACKING OPTION	SORT
CJ78L-5.0	CJ78L05	SOT-23-3L	-40 ~ 125°C	RoHS & Green	Level 3 168 HR	Tape and Reel 1000 Units / Reel	Active
CJ78L-5.0	CJ78L05	SOT-89-3L	-40 ~ 125°C	RoHS & Green	Level 3 168 HR	Tape and Reel 1000 Units / Reel	Active
CJ78L-6.0	CJ78L06	SOT-89-3L	-40 ~ 125°C	RoHS & Green	Level 3 168 HR	Tape and Reel 1000 Units / Reel	Active
CJ78L-8.0	CJ78L08	SOT-89-3L	-40 ~ 125°C	RoHS & Green	Level 3 168 HR	Tape and Reel 1000 Units / Reel	Active
CJ78L-9.0	CJ78L09	SOT-89-3L	-40 ~ 125°C	RoHS & Green	Level 3 168 HR	Tape and Reel 1000 Units / Reel	Active
CJ78L-12	CJ78L12	SOT-89-3L	-40 ~ 125°C	RoHS & Green	Level 3 168 HR	Tape and Reel 1000 Units / Reel	Active
CJ78L-15	CJ78L15	SOT-89-3L	-40 ~ 125°C	RoHS & Green	Level 3 168 HR	Tape and Reel 1000 Units / Reel	Active
CJ78L-5.0	CJ78L05	TO-92	-40 ~ 125°C	RoHS & Green	Level 3 168 HR	Bulk 1000 Units / Bag	Active
CJ78L-6.0	CJ78L06	TO-92	-40 ~ 125°C	RoHS & Green	Level 3 168 HR	Bulk 1000 Units / Bag	Active
CJ78L-8.0	CJ78L08	TO-92	-40 ~ 125°C	RoHS & Green	Level 3 168 HR	Bulk 1000 Units / Bag	Active
CJ78L-9.0	CJ78L09	TO-92	-40 ~ 125°C	RoHS & Green	Level 3 168 HR	Bulk 1000 Units / Bag	Active
CJ78L-12	CJ78L12	TO-92	-40 ~ 125°C	RoHS & Green	Level 3 168 HR	Bulk 1000 Units / Bag	Active
CJ78L-15	CJ78L15	TO-92	-40 ~ 125°C	RoHS & Green	Level 3 168 HR	Bulk 1000 Units / Bag	Active

5 Orderable Information

MODEL	DEVICE	PACKAGE	OP T _J	ECO PLAN	MSL	PACKING OPTION	SORT
CJ78L-5.0	CJ78L05-TA	TO-92	-40 ~ 125°C	RoHS & Green	Level 3 168 HR	Ammo 2000 Units / Box	Active
CJ78L-6.0	CJ78L06-TA	TO-92	-40 ~ 125°C	RoHS & Green	Level 3 168 HR	Ammo 2000 Units / Box	Active
CJ78L-8.0	CJ78L08-TA	TO-92	-40 ~ 125°C	RoHS & Green	Level 3 168 HR	Ammo 2000 Units / Box	Active
CJ78L-9.0	CJ78L09-TA	TO-92	-40 ~ 125°C	RoHS & Green	Level 3 168 HR	Ammo 2000 Units / Box	Active
CJ78L-12	CJ78L12-TA	TO-92	-40 ~ 125°C	RoHS & Green	Level 3 168 HR	Ammo 2000 Units / Box	Active
CJ78L-15	CJ78L15-TA	TO-92	-40 ~ 125°C	RoHS & Green	Level 3 168 HR	Ammo 2000 Units / Box	Active
Others	-	-	-	-	-	-	Customized

Note:

ECO PLAN: For the RoHS and Green certification standards of this product, please refer to the official report provided by JSCJ.

MSL: Moisture Sensitivity Level. Determined according to JEDEC industry standard classification.

SORT: Specifically defined as follows:

Active: Recommended for new products;

Customized: Products manufactured to meet the specific needs of customers;

Preview: The device has been released and has not been fully mass produced. The sample may or may not be available;

NoRD: It is not recommended to use the device for new design. The device is only produced for the needs of existing customers;

Obsolete: The device has been discontinued.

6 Pin Configuration and Marking Information

6.1 Pin Configuration and Function

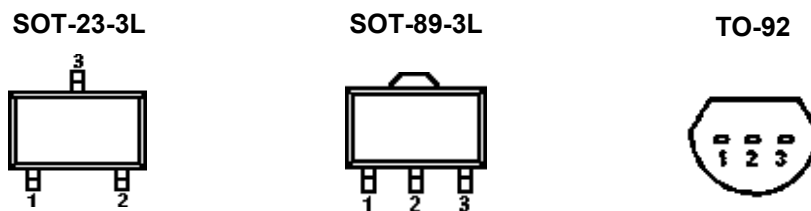
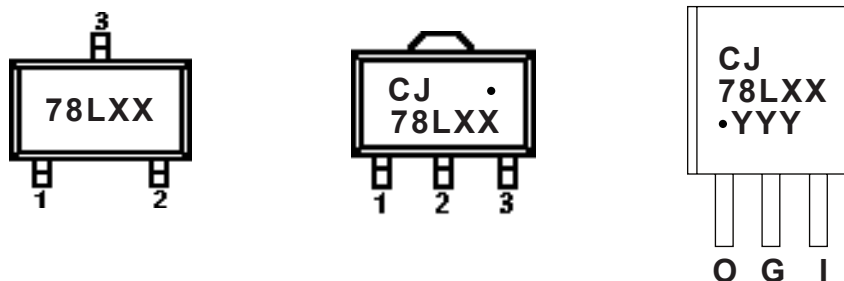

Figure 5-1. Package Top View

PIN NAME	CJ78L Series			I / O	DESCRIPTION
	SOT-23-3L	SOT-89-3L	TO-92		
IN	2	3	3	I	Input to the device.
GND	3	2	2	-	Regulator ground.
OUT	1	1	1	O	Output of the regulator.

6.2 Marking Information



"78LXX or CJ78LXX": Product number, the "XX" in the "78LXX" or "CJ78LXX" represents the output voltage, for example, if $V_{OUT} = 5.0V$, "XX" is "05".

"." Solid dot: Green molding compound device.

"YYY": Code.

7 Specifications

7.1 Absolute Maximum Ratings⁽¹⁾

CHARACTERISTIC		SYMBOL	VALUE	UNIT
Maximum input voltage ⁽²⁾	CJ78L05	V _{IN}	30	V
	CJ78L06			
	CJ78L08			
	CJ78L09		35	
	CJ78L12			
	CJ78L15			
Maximum power dissipation	SOT-23-3L	P _{D Max}	Internally Limited ⁽³⁾	W
	SOT-23-5L			
	SOT-89-3L			
	TO-92			
Maximum junction temperature		T _{J Max}	150	°C
Storage temperature		T _{stg}	- 65 ~ 150	°C
Soldering temperature & time		T _{solder}	260°C, 10s	-

(1) Stresses beyond those listed under *Absolute Maximum Ratings* may cause permanent damage to the device. These are stress ratings only, which do not imply functional operation of the device at these or any other conditions beyond those indicated under *Recommended Operating Conditions*. Exposure to absolute-maximum rated conditions for extended periods may affect device reliability.

(2) All voltages are with respect to network ground terminal.

(3) Refer to *Thermal Information* for details.

7.2 Recommended Operating Conditions⁽⁴⁾

PARAMETER	SYMBOL	MIN.	NOM.	MAX.	UNIT
Operating Junction Temperature	T _J	-40	-	125	°C
Operating Ambient Temperature	T _A	-	-(5)	-	°C

(4) CJ recommends that users should not exceed the rated value in the *Recommended Operating Conditions* for the application conditions of the equipment, so as to ensure the stability of normal operation and reliability of long-term operation of the equipment. Operation beyond the recommended rated conditions does not mean that the product will fail. The consumers need to evaluate the risks that may be caused by the operation of the product beyond the recommended rated conditions.

(5) It is necessary to ensure that the operating junction temperature of the equipment does not exceed the rated value of the recommended operating conditions when using the device for design.

7 Specifications

7.3 ESD Ratings

ESD RATINGS		SYMBOL	VALUE	UNIT
Electrostatic discharge ⁽⁶⁾	Human body model	$V_{ESD-HBM}$	2000	V
	Machine model	V_{ESD-MM}	400	

(6) ESD testing is conducted in accordance with the relevant specifications formulated by the Joint Electronic Equipment Engineering Commission (JEDEC). The human body mode (HBM) electrostatic discharge test is based on the JESD22-114D test standard, using a 100pF capacitor and discharging to each pin of the device through a resistance of 1.5kΩ. The electrostatic discharge test in mechanical mode (MM) is based on the JESD22-115-A test standard and uses a 200pF capacitor to discharge directly to each pin of the device.

7.4 Thermal Information

THERMAL METRIC ⁽⁷⁾	SYMBOL	CJ78L Series			UNIT
		SOT-23-3L	SOT-89-3L	TO-92	
Junction-to-ambient thermal resistance	$R_{\theta JA}$	250.0	160.0	160.0	°C/W
Reference value of maximum power consumption for continuous operation	$P_{D Ref}$	0.40	0.63	0.63	W

(7) $T_A = 25^\circ\text{C}$, see the part *Notes* for more information about thermal metrics.

7 Specifications

7.5 Electrical Characteristics

CJ78L05 ($V_{OUT} = 5.0V$, $V_{IN} = 10V$, $I_{OUT} = 40mA$, $C_{IN} = 0.33\mu F$, $C_{OUT} = 0.1\mu F$, $T_J = 25^\circ C$, unless otherwise specified)

CHARACTERISTIC	SYMBOL	TEST CONDITIONS	MIN.	TYP. ⁽⁸⁾	MAX.	UNIT
Input voltage	V_{IN}	-	-	-	30	V
Output voltage	V_{OUT}	$T_J = 25^\circ C$	4.85	5.00	5.15	V
		$V_{IN} = 7$ to 20V, $I_{OUT} = 1$ to 40mA	4.75	5.00	5.25	
		$I_{OUT} = 1$ to 70mA	4.75	5.00	5.25	
Output current	I_{OUT}	$T_J = 25^\circ C$	100	-	-	mA
Quiescent current	I_Q	$I_{OUT} = 0mA$	-	3.8	6.0	mA
Quiescent current change	ΔI_Q	$V_{IN} = 8$ to 20V	-	-	1.5	mA
		$I_{OUT} = 1$ to 40mA	-	-	0.1	mA
Dropout voltage	$V_{DO}^{(9)}$	$T_J = 25^\circ C$	-	1.7	-	V
Line regulation	ΔV_{LINE}	$V_{IN} = 7$ to 20V, $T_J = 25^\circ C$	-	32	150	mV
		$V_{IN} = 8$ to 20V, $T_J = 25^\circ C$	-	26	100	
Load regulation	ΔV_{LOAD}	$I_{OUT} = 1$ to 100mA, $T_J = 25^\circ C$	-	15	60	mV
		$I_{OUT} = 1$ to 40mA, $T_J = 25^\circ C$	-	8	30	
Output noise voltage	V_N	$f = 10$ to 100kHz, $T_J = 25^\circ C$	-	42	-	$\mu V/V_{OUT}$
Ripple rejection	RR	$V_{IN} = 8$ to 20V, $f = 120Hz$	41	49	-	dB

Note:

(8) Typical numbers are at $25^\circ C$ (T_J) and represent the most likely norm.

(9) Test the difference of output voltage and input voltage when input voltage is decreased gradually till output voltage equals to 95% of V_{OUT} .

7 Specifications

7.5 Electrical Characteristics (continued)

CJ78L06 ($V_{OUT} = 6.0V$, $V_{IN} = 11V$, $I_{OUT} = 40mA$, $C_{IN} = 0.33\mu F$, $C_{OUT} = 0.1\mu F$, $T_J = 25^\circ C$, unless otherwise specified)

CHARACTERISTIC	SYMBOL	TEST CONDITIONS	MIN.	TYP. ⁽⁸⁾	MAX.	UNIT
Input voltage	V_{IN}	-	-	-	30	V
Output voltage	V_{OUT}	$T_J = 25^\circ C$	5.82	6.00	6.18	V
		$V_{IN} = 8$ to $20V$, $I_{OUT} = 1$ to $40mA$	5.70	6.00	6.30	
		$I_{OUT} = 1$ to $70mA$	5.70	6.00	6.30	
Output current	I_{OUT}	$T_J = 25^\circ C$	100	-	-	mA
Quiescent current	I_Q	$I_{OUT} = 0mA$	-	3.9	6.0	mA
Quiescent current change	ΔI_Q	$V_{IN} = 9$ to $20V$	-	-	1.5	mA
		$I_{OUT} = 1$ to $40mA$	-	-	0.1	mA
Dropout voltage	$V_{DO}^{(9)}$	$T_J = 25^\circ C$	-	1.7	-	V
Line regulation	ΔV_{LINE}	$V_{IN} = 8$ to $20V$, $T_J = 25^\circ C$	-	35	175	mV
		$V_{IN} = 9$ to $20V$, $T_J = 25^\circ C$	-	29	125	
Load regulation	ΔV_{LOAD}	$I_{OUT} = 1$ to $100mA$, $T_J = 25^\circ C$	-	16	80	mV
		$I_{OUT} = 1$ to $40mA$, $T_J = 25^\circ C$	-	9	40	
Output noise voltage	V_N	$f = 10$ to $100kHz$, $T_J = 25^\circ C$	-	46	-	$\mu V/V_{OUT}$
Ripple rejection	RR	$V_{IN} = 9$ to $19V$, $f = 120Hz$	40	48	-	dB

Note:

(8) Typical numbers are at $25^\circ C$ (T_J) and represent the most likely norm.

(9) Test the difference of output voltage and input voltage when input voltage is decreased gradually till output voltage equals to 95% of V_{OUT} .

7 Specifications

7.5 Electrical Characteristics (continued)

CJ78L08 ($V_{OUT} = 8.0V$, $V_{IN} = 14V$, $I_{OUT} = 40mA$, $C_{IN} = 0.33\mu F$, $C_{OUT} = 0.1\mu F$, $T_J = 25^\circ C$, unless otherwise specified)

CHARACTERISTIC	SYMBOL	TEST CONDITIONS	MIN.	TYP. ⁽⁸⁾	MAX.	UNIT
Input voltage	V_{IN}	-	-	-	30	V
Output voltage	V_{OUT}	$T_J = 25^\circ C$	7.76	8.00	8.24	V
		$V_{IN} = 10.5$ to $23V$, $I_{OUT} = 1$ to $40mA$	7.60	8.00	8.40	
		$I_{OUT} = 1$ to $70mA$	7.76	8.00	8.40	
Output current	I_{OUT}	$T_J = 25^\circ C$	100	-	-	mA
Quiescent current	I_Q	$I_{OUT} = 0mA$	-	4.0	6.0	mA
Quiescent current change	ΔI_Q	$V_{IN} = 11$ to $23V$	-	-	1.5	mA
		$I_{OUT} = 1$ to $40mA$	-	-	0.1	mA
Dropout voltage	$V_{DO}^{(9)}$	$T_J = 25^\circ C$	-	1.7	-	V
Line regulation	ΔV_{LINE}	$V_{IN} = 10.5$ to $23V$, $T_J = 25^\circ C$	-	42	175	mV
		$V_{IN} = 11$ to $23V$, $T_J = 25^\circ C$	-	36	125	
Load regulation	ΔV_{LOAD}	$I_{OUT} = 1$ to $100mA$, $T_J = 25^\circ C$	-	18	80	mV
		$I_{OUT} = 1$ to $40mA$, $T_J = 25^\circ C$	-	10	40	
Output noise voltage	V_N	$f = 10$ to $100kHz$, $T_J = 25^\circ C$	-	54	-	$\mu V/V_{OUT}$
Ripple rejection	RR	$V_{IN} = 13$ to $23V$, $f = 120Hz$	37	46	-	dB

Note:

(8) Typical numbers are at $25^\circ C$ (T_J) and represent the most likely norm.

(9) Test the difference of output voltage and input voltage when input voltage is decreased gradually till output voltage equals to 95% of V_{OUT} .

7 Specifications

7.5 Electrical Characteristics (continued)

CJ78L09 ($V_{OUT} = 9.0V$, $V_{IN} = 16V$, $I_{OUT} = 40mA$, $C_{IN} = 0.33\mu F$, $C_{OUT} = 0.1\mu F$, $T_J = 25^\circ C$, unless otherwise specified)

CHARACTERISTIC	SYMBOL	TEST CONDITIONS	MIN.	TYP. ⁽⁸⁾	MAX.	UNIT
Input voltage	V_{IN}	-	-	-	30	V
Output voltage	V_{OUT}	$T_J = 25^\circ C$	8.73	9.00	9.27	V
		$V_{IN} = 12$ to $24V$, $I_{OUT} = 1$ to $40mA$	8.55	9.00	9.45	
		$I_{OUT} = 1$ to $70mA$	8.55	9.00	9.45	
Output current	I_{OUT}	$T_J = 25^\circ C$	100	-	-	mA
Quiescent current	I_Q	$I_{OUT} = 0mA$	-	4.1	6.0	mA
Quiescent current change	ΔI_Q	$V_{IN} = 13$ to $24V$	-	-	1.5	mA
		$I_{OUT} = 1$ to $40mA$	-	-	0.1	mA
Dropout voltage	$V_{DO}^{(9)}$	$T_J = 25^\circ C$	-	1.7	-	V
Line regulation	ΔV_{LINE}	$V_{IN} = 12$ to $24V$, $T_J = 25^\circ C$	-	45	175	mV
		$V_{IN} = 13$ to $24V$, $T_J = 25^\circ C$	-	40	125	
Load regulation	ΔV_{LOAD}	$I_{OUT} = 1$ to $100mA$, $T_J = 25^\circ C$	-	19	90	mV
		$I_{OUT} = 1$ to $40mA$, $T_J = 25^\circ C$	-	11	40	
Output noise voltage	V_N	$f = 10$ to $100kHz$, $T_J = 25^\circ C$	-	58	-	$\mu V/V_{OUT}$
Ripple rejection	RR	$V_{IN} = 15$ to $25V$, $f = 120Hz$	37	45	-	dB

Note:

(8) Typical numbers are at $25^\circ C$ (T_J) and represent the most likely norm.

(9) Test the difference of output voltage and input voltage when input voltage is decreased gradually till output voltage equals to 95% of V_{OUT} .

7 Specifications

7.5 Electrical Characteristics (continued)

CJ78L12 ($V_{OUT} = 12V$, $V_{IN} = 19V$, $I_{OUT} = 40mA$, $C_{IN} = 0.33\mu F$, $C_{OUT} = 0.1\mu F$, $T_J = 25^\circ C$, unless otherwise specified)

CHARACTERISTIC	SYMBOL	TEST CONDITIONS	MIN.	TYP. ⁽⁸⁾	MAX.	UNIT
Input voltage	V_{IN}	-	-	-	35	V
Output voltage	V_{OUT}	$T_J = 25^\circ C$	11.64	12.00	12.36	V
		$V_{IN} = 14$ to $27V$, $I_{OUT} = 1$ to $40mA$	11.40	12.00	12.60	
		$I_{OUT} = 1$ to $70mA$	11.40	12.00	12.60	
Output current	I_{OUT}	$T_J = 25^\circ C$	100	-	-	mA
Quiescent current	I_Q	$I_{OUT} = 0mA$	-	4.3	6.5	mA
Quiescent current change	ΔI_Q	$V_{IN} = 14.5$ to $27V$	-	-	1.5	mA
		$I_{OUT} = 1$ to $40mA$	-	-	0.1	mA
Dropout voltage	$V_{DO}^{(9)}$	$T_J = 25^\circ C$	-	1.7	-	V
Line regulation	ΔV_{LINE}	$V_{IN} = 14.5$ to $27V$, $T_J = 25^\circ C$	-	55	250	mV
		$V_{IN} = 16$ to $27V$, $T_J = 25^\circ C$	-	49	200	
Load regulation	ΔV_{LOAD}	$I_{OUT} = 1$ to $100mA$, $T_J = 25^\circ C$	-	22	100	mV
		$I_{OUT} = 1$ to $40mA$, $T_J = 25^\circ C$	-	13	50	
Output noise voltage	V_N	$f = 10$ to $100kHz$, $T_J = 25^\circ C$	-	70	-	$\mu V/V_{OUT}$
Ripple rejection	RR	$V_{IN} = 15$ to $25V$, $f = 120Hz$	37	42	-	dB

Note:

(8) Typical numbers are at $25^\circ C$ (T_J) and represent the most likely norm.

(9) Test the difference of output voltage and input voltage when input voltage is decreased gradually till output voltage equals to 95% of V_{OUT} .

7 Specifications

7.5 Electrical Characteristics (continued)

CJ78L15 ($V_{OUT} = 15V$, $V_{IN} = 23V$, $I_{OUT} = 40mA$, $C_{IN} = 0.33\mu F$, $C_{OUT} = 0.1\mu F$, $T_J = 25^\circ C$, unless otherwise specified)

CHARACTERISTIC	SYMBOL	TEST CONDITIONS	MIN.	TYP. ⁽⁸⁾	MAX.	UNIT
Input voltage	V_{IN}	-	-	-	35	V
Output voltage	V_{OUT}	$T_J = 25^\circ C$	14.55	15.00	15.45	V
		$V_{IN} = 17.5$ to $30V$, $I_{OUT} = 1$ to $40mA$	14.25	15.00	15.75	
		$I_{OUT} = 1$ to $70mA$	14.25	15.00	15.75	
Output current	I_{OUT}	$T_J = 25^\circ C$	100	-	-	mA
Quiescent current	I_Q	$I_{OUT} = 0mA$	-	4.6	6.5	mA
Quiescent current change	ΔI_Q	$V_{IN} = 19$ to $30V$	-	-	1.5	mA
		$I_{OUT} = 1$ to $40mA$	-	-	0.1	mA
Dropout voltage	$V_{DO}^{(9)}$	$T_J = 25^\circ C$	-	1.7	-	V
Line regulation	ΔV_{LINE}	$V_{IN} = 17.5$ to $30V$, $T_J = 25^\circ C$	-	65	300	mV
		$V_{IN} = 19$ to $30V$, $T_J = 25^\circ C$	-	58	250	
Load regulation	ΔV_{LOAD}	$I_{OUT} = 1$ to $100mA$, $V_{IN} = 23V$, $T_J = 25^\circ C$	-	25	150	mV
		$I_{OUT} = 1$ to $40mA$, $V_{IN} = 23V$, $T_J = 25^\circ C$	-	15	75	
Output noise voltage	V_N	$f = 10$ to $100kHz$, $T_J = 25^\circ C$	-	82	-	$\mu V/V_{OUT}$
Ripple rejection	RR	$V_{IN} = 18.5$ to $28.5V$, $f = 120Hz$	34	39	-	dB

Note:

(8) Typical numbers are at $25^\circ C$ (T_J) and represent the most likely norm.

(9) Test the difference of output voltage and input voltage when input voltage is decreased gradually till output voltage equals to 95% of V_{OUT} .

7 Specifications

7.6 Typical Characteristics

CJ78L05 ($V_{OUT} = 5.0V$, $T_J = 25^\circ C$, unless otherwise specified)

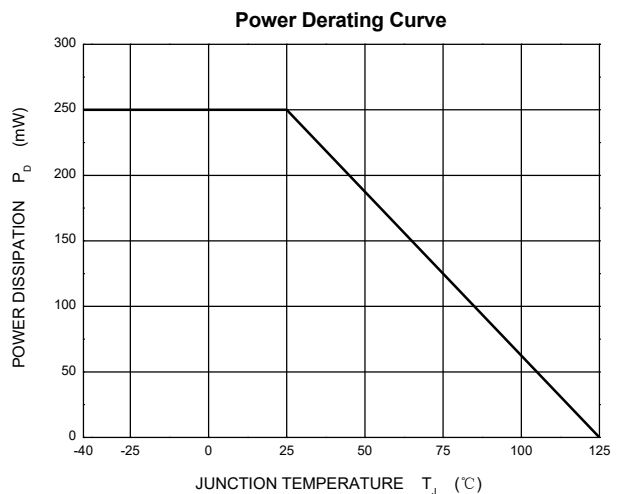
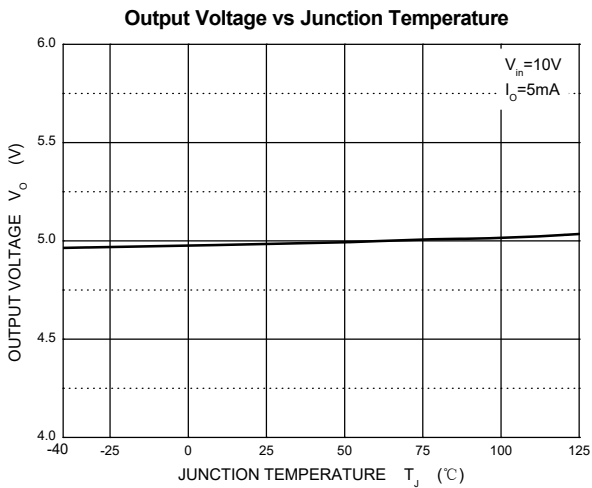
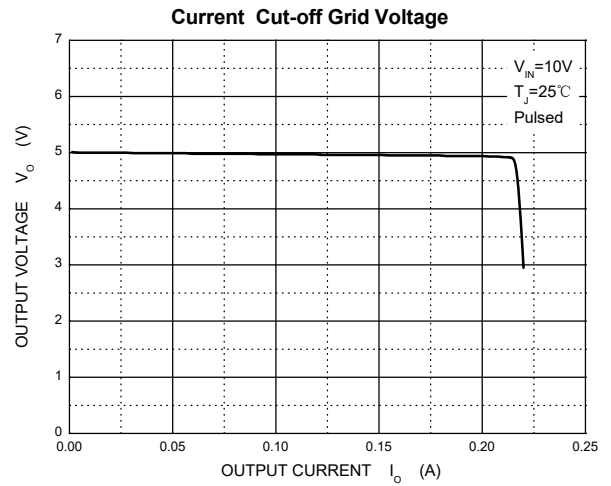
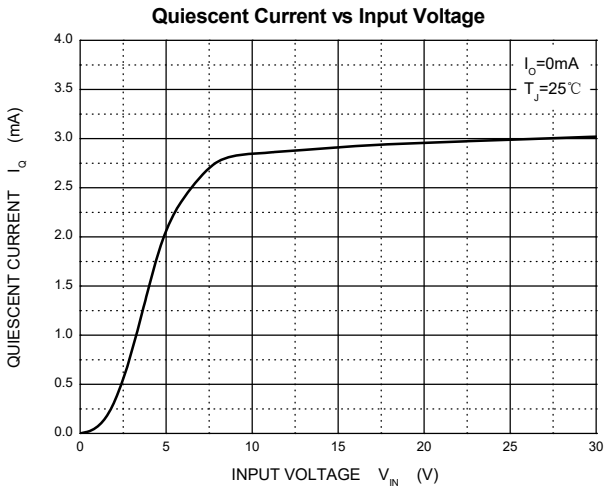
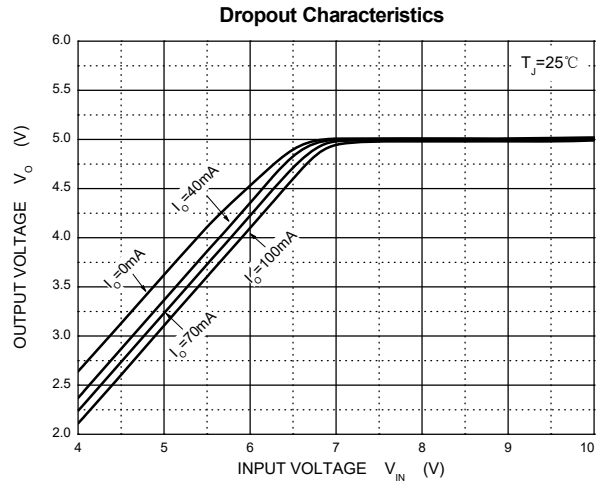
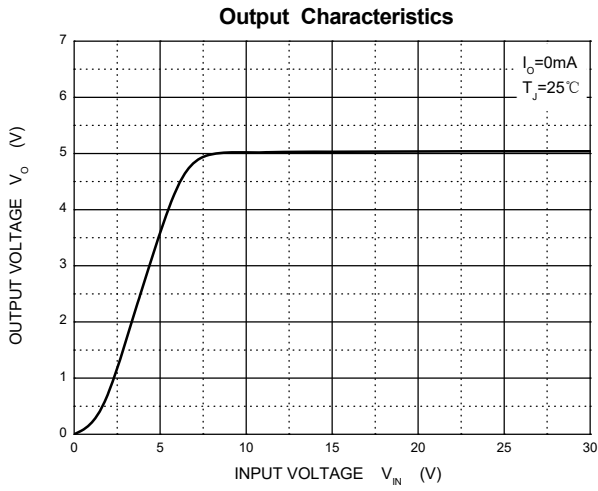

7 Specifications

7.6 Typical Characteristics (continued)

CJ78L06 ($V_{OUT} = 6.0V$, $T_J = 25^\circ C$, unless otherwise specified)

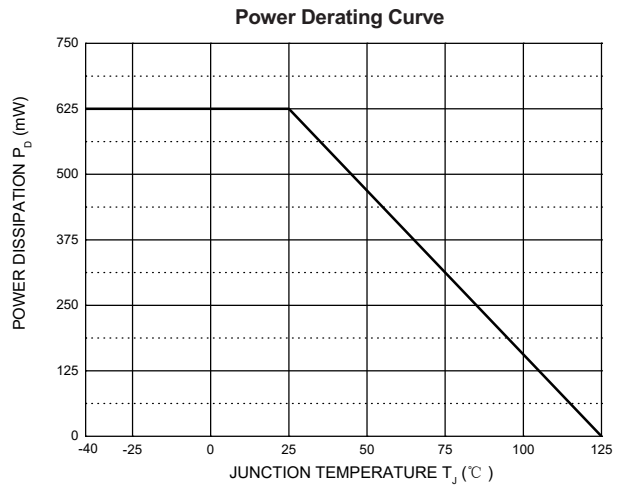
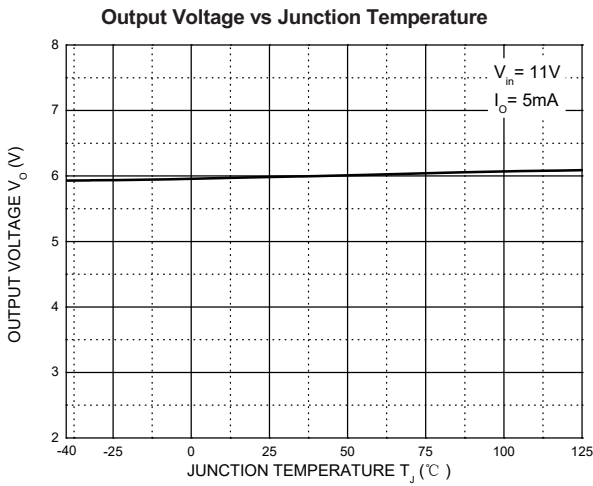
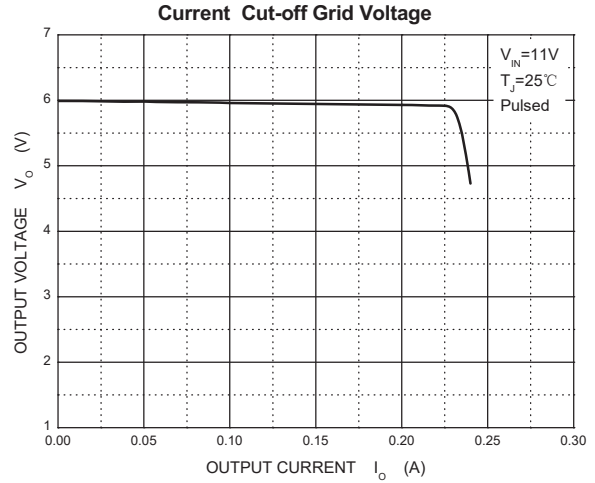
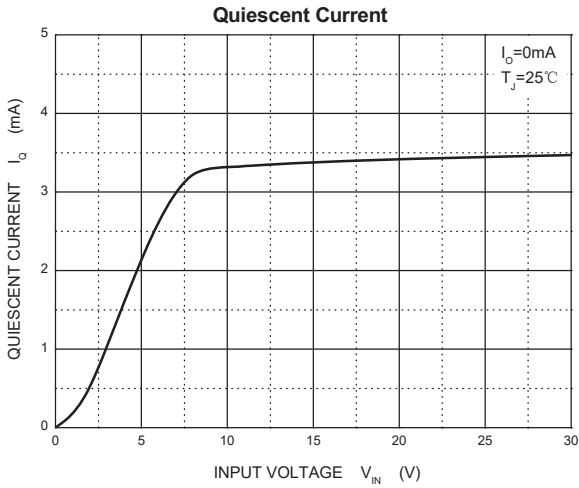
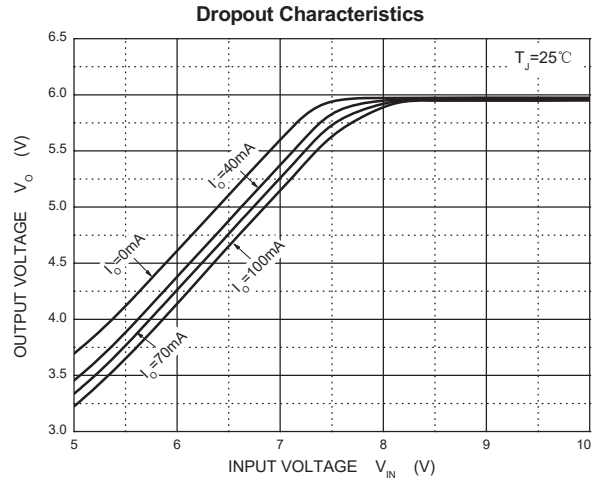
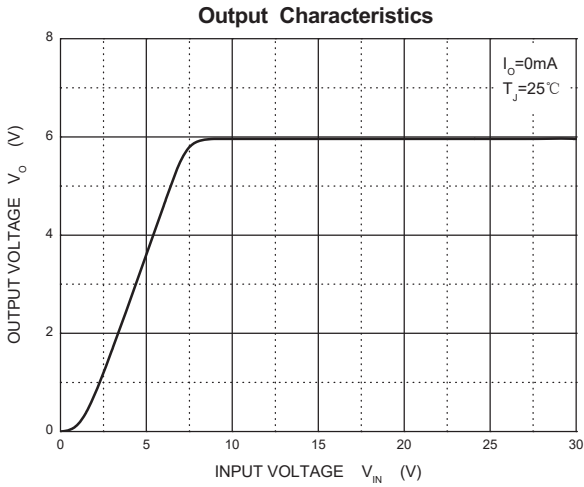

7 Specifications

7.6 Typical Characteristics (continued)

CJ78L08 ($V_{OUT} = 8.0V$, $T_J = 25^\circ C$, unless otherwise specified)

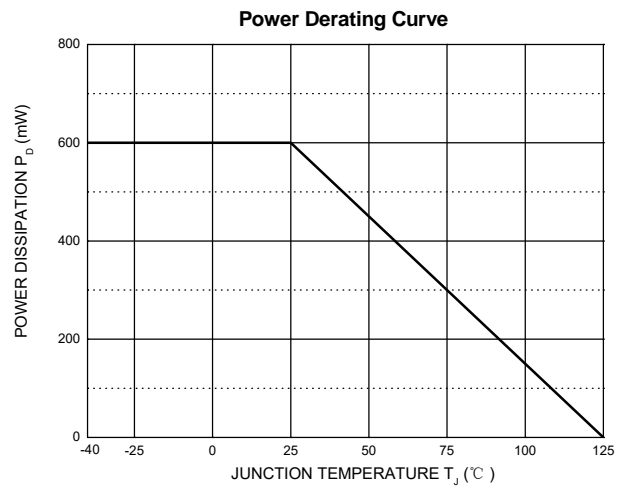
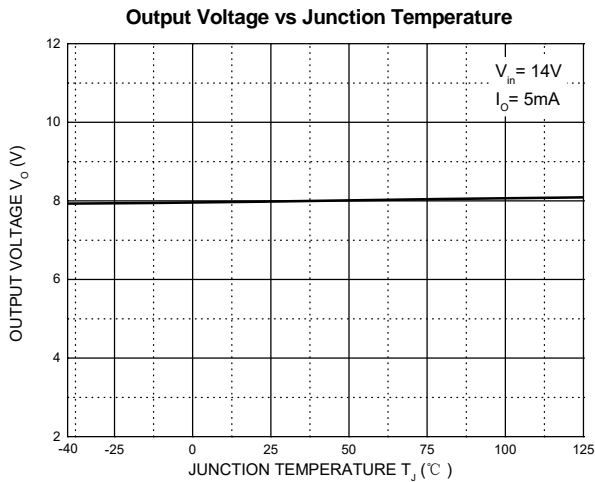
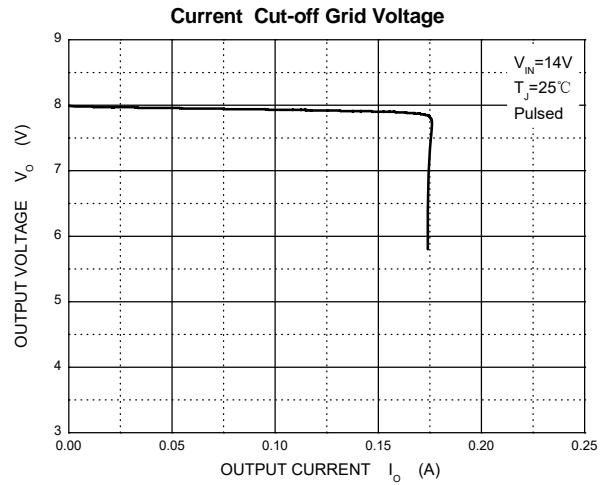
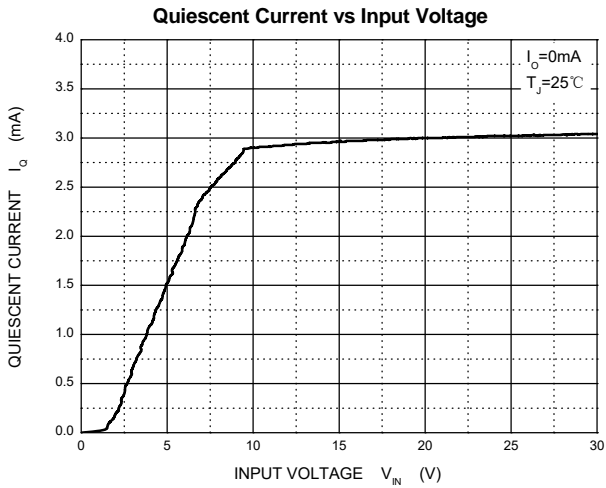
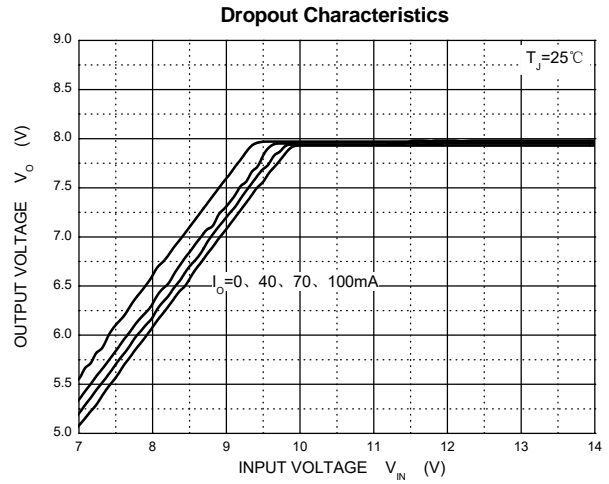
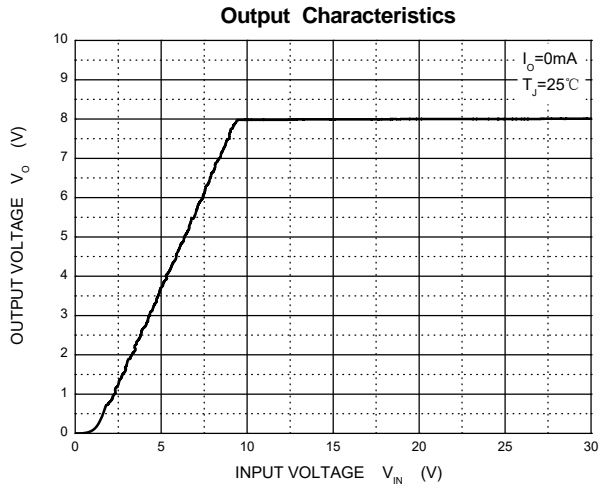

7 Specifications

7.6 Typical Characteristics (continued)

CJ78L09 ($V_{OUT} = 9.0V$, $T_J = 25^\circ C$, unless otherwise specified)

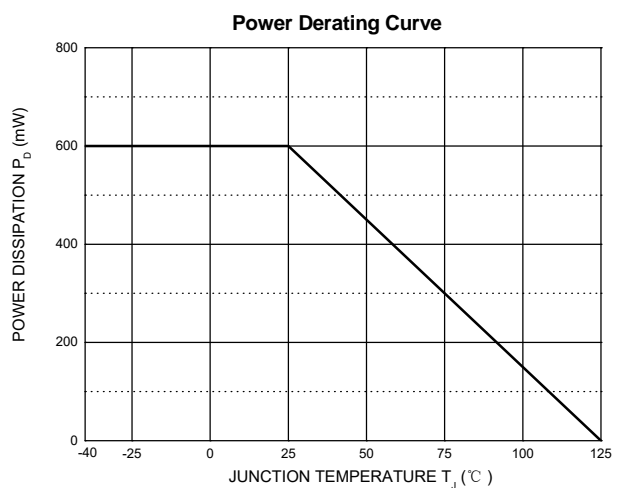
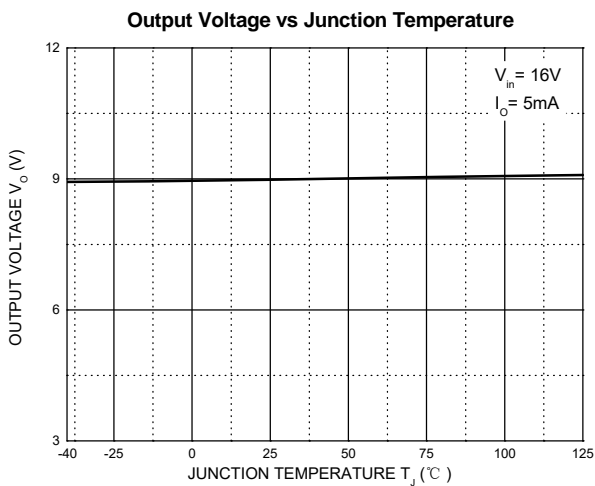
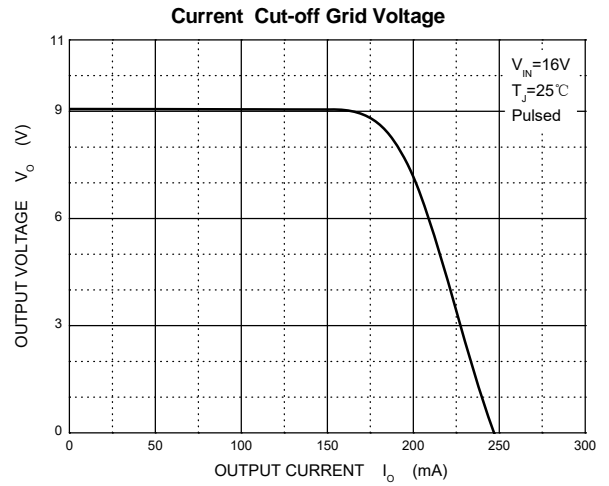
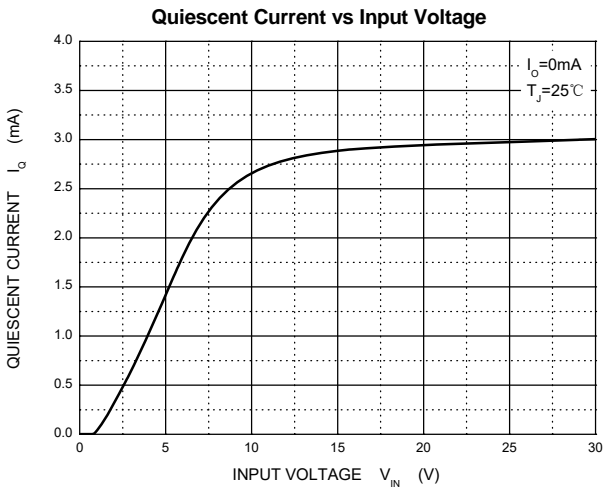
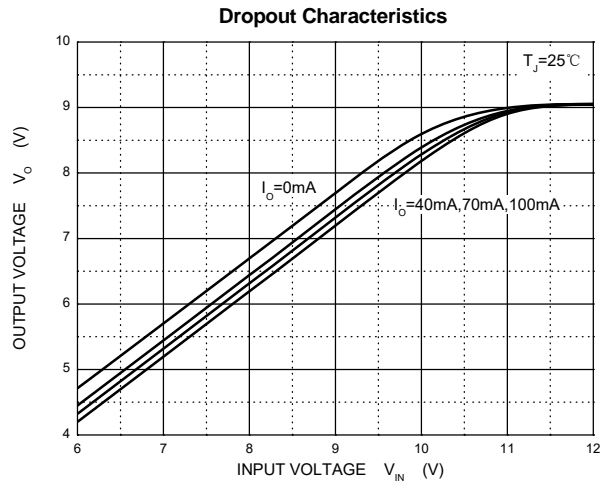
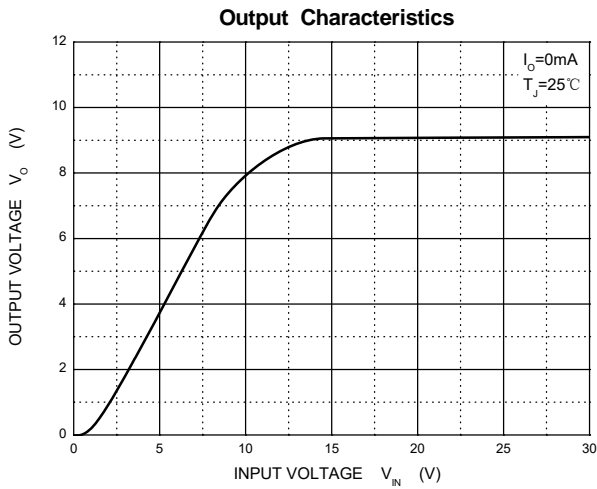

7 Specifications

7.6 Typical Characteristics (continued)

CJ78L12 ($V_{OUT} = 12V$, $T_J = 25^\circ C$, unless otherwise specified)

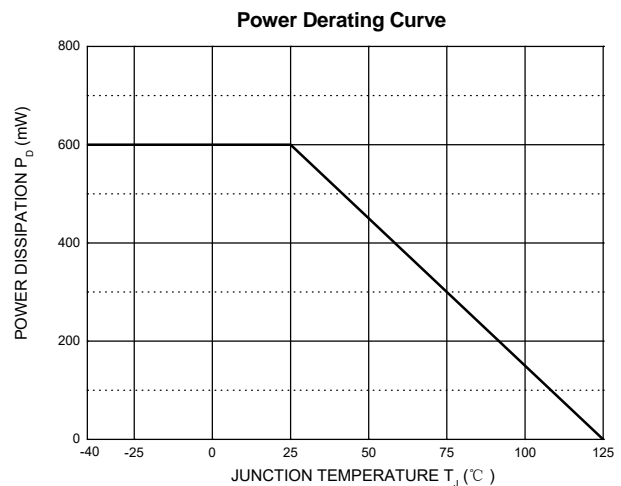
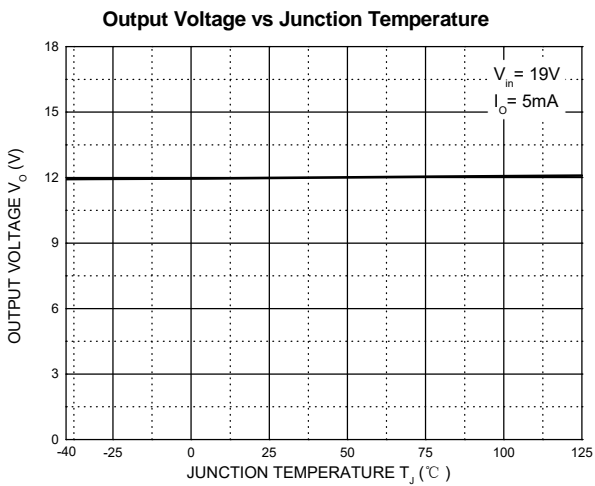
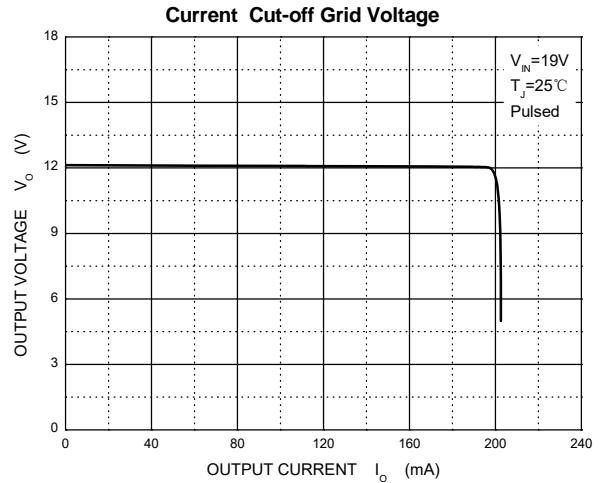
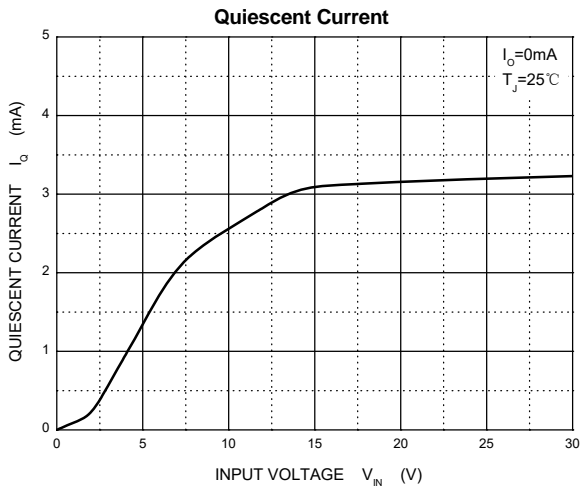
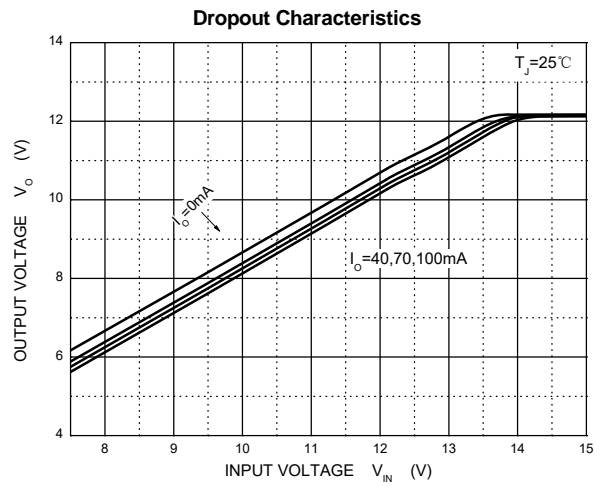
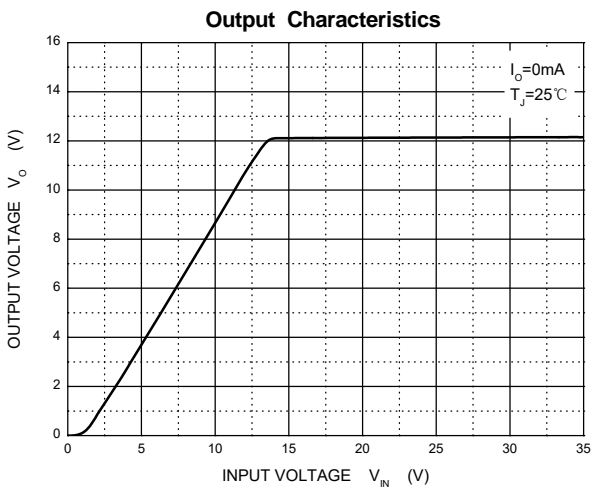

7 Specifications

7.6 Typical Characteristics (continued)

CJ78L15 ($V_{OUT} = 15V$, $T_J = 25^\circ C$, unless otherwise specified)

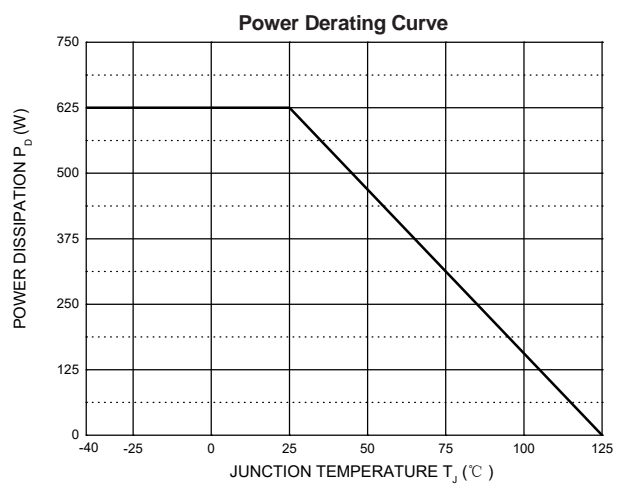
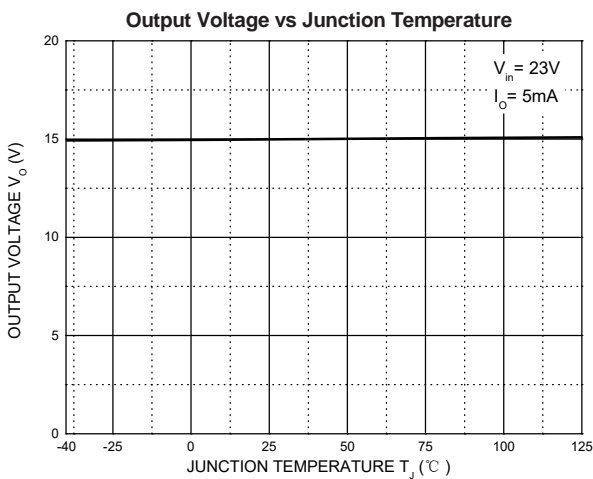
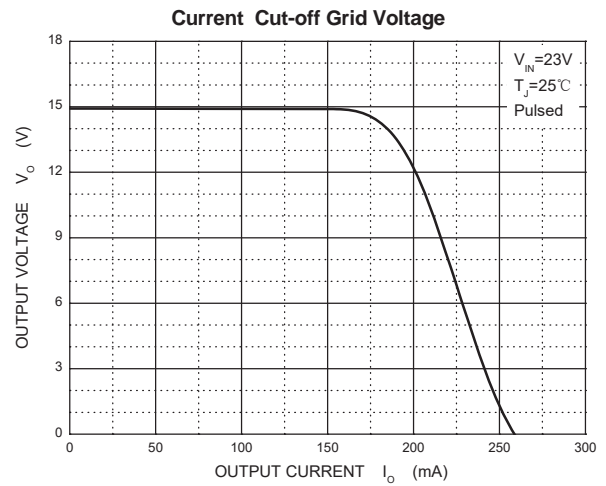
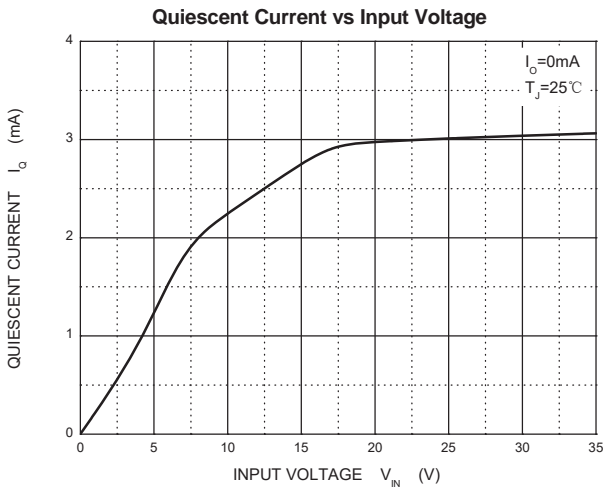
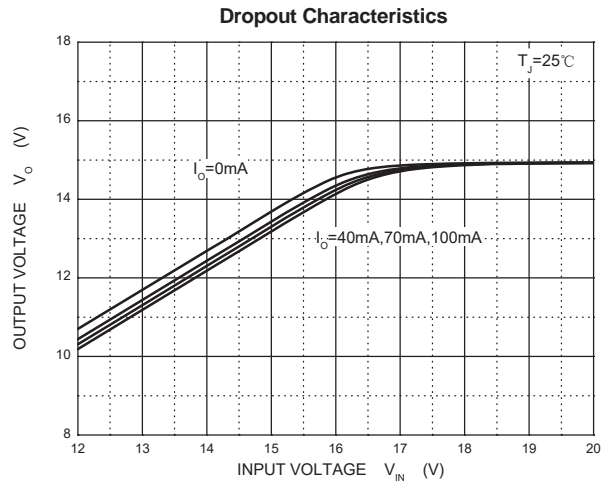
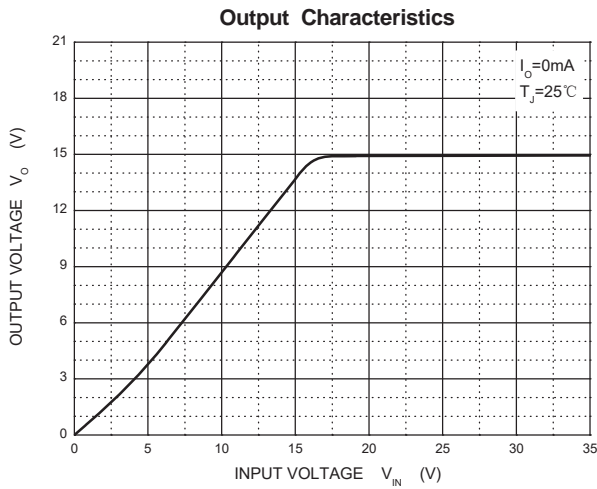

8 Detailed Description

8.1 Description

The CJ78L series integrates current limit, short circuit protection and thermal shutdown to reduce the possibility of circuit overload. The CJ78L series has a fixed output voltage version, which allows the fixed output CJ78L series to be used as an output circuit with adjustable voltage by setting two peripheral resistors.

8.2 Representative Schematic Diagram

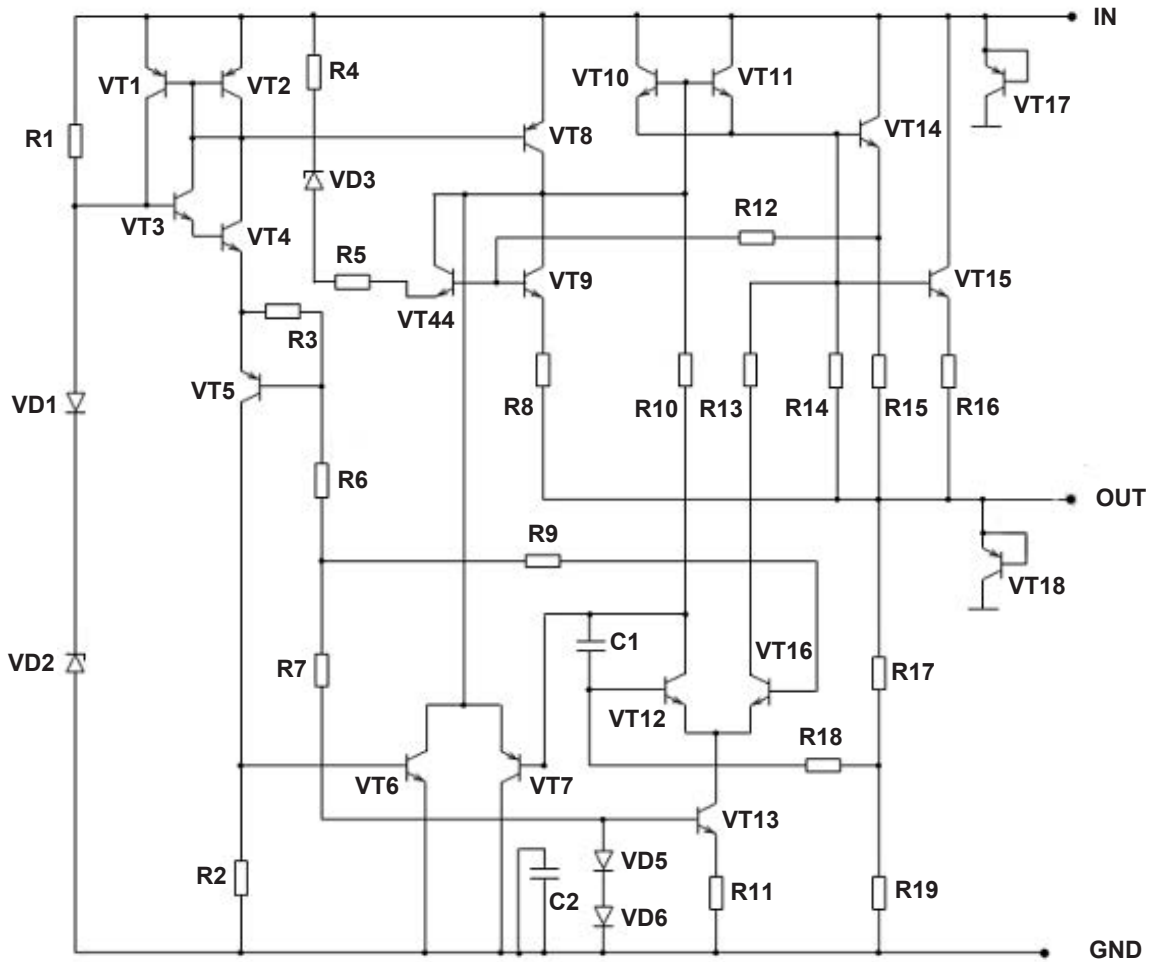

8 Detailed Description

8.3 Feature Description

Input Voltage

When the input voltage is lower than the rated range of the data sheet, the device will lose the regulation function of stabilizing the output voltage, that is, it is unable to maintain the output voltage within the rated range. At this time, compared with normal operation, the quiescent current of the device may exceed the rated range, and the transient response performance of the device may be seriously degraded.

When the input voltage is higher than the rated range of the data sheet, the device may cause irreversible damage or failure due to exceeding the maximum rated range of electrical stress.

Output Current

When the circuit design is appropriate, the CJ78L series can reach the maximum load capacity of at least 100mA. According to the heat dissipation power consumption of the package and the effective connection thermal resistance with the environment, selecting the appropriate package for the circuit design can make the device emit more heat energy.

Thermal Shutdown

The CJ78L series has thermal shutdown protection mechanism. When the junction temperature exceeds the rated temperature range for normal operation in the data sheet, the device will enter the thermal shutdown state. At this time, the output voltage of the device will be reduced to prevent catastrophic damage to the chip due to accidental heat. When the junction temperature decreases and no longer remains too high, the device will release the thermal shutdown and output normally.

To ensure reliable operation, please limit the junction temperature to the specified range of *Recommended Operating Conditions* in the data sheet. Applications that exceed the recommended temperature range may cause the equipment to exceed its operating specifications. Although the internal protection circuitry of the device is designed to protect against thermal overall conditions, this circuitry is not intended to replace proper heat sinking. Continuously running the device into thermal shutdown or above the maximum recommended junction temperature reduces long-term reliability.

Current Limit & Short Circuit Protection

The CJ78L series has current limiting and short circuit protection mechanism. When the output current of the device is too high, the output of the device will be shut down. When the output of the device is short circuited to ground, the output of the device will also be shut down and the output current will be maintained within a certain range.

9 Application and Implementation

9.1 Risk Alert and Precautions

The CJ78L series is designed for thermal protection, output short circuit protection and built-in current limit. However, like any IC regulator, precautions are necessary to reduce the possibility of accidental damage to the regulator. The following describes the possible causes of unit damage or failure:

Electrostatic Discharge (ESD)

Electrostatic discharge (ESD) is a common near-field hazard source. It comes from many sources, such as human body, mechanical equipment and electronic components themselves. ESD can cause phenomena such as high voltage and instantaneous high current in a very short time, resulting in damage or failure of the device due to electric shock.

Instantaneous Electrical Surge

In some applications, a short duration but high energy spike may occur in the circuit, including peak voltage and surge current. They may cause unstable operation of the regulator, accelerated aging and potential hazards, and even damage or malfunction of the regulator. These peaks are usually more likely to occur in hot-plug, switch inductance, heavy-load, and other types of circuits.

Precautions for ESD and Electrical Surge

In the practical application of the circuit, adopting the following suggestions can reduce the possibility of device failure due to the above reasons to a certain extent.

1. Place a TVS between the IN and GND of the voltage regulator to absorb the peak voltage that may be generated due to ESD or other reasons. As shown in Figure 9-1;
2. Place a resistor with appropriate resistance in series before the IN of the voltage regulator, which can help the voltage regulator share part of the energy in case of surge. The resistance value of the resistance should not be too large. The specific resistance value depends on the application of the circuit. Generally, the resistance value of this resistance does not exceed 20Ω. As shown in Figure 9-2.

For the CJ78L05, CJ78L06, CJ78L08, CJ78L09, it is recommended that the input voltage should not exceed 16V and the peak voltage should not exceed 30V. For the CJ78L12, CJ78L15, it is recommended that the input voltage should not exceed 18V and the peak voltage should not exceed 35V. **When the input voltage of the operating circuit may not meet the application conditions described above, it is recommended to adopt the circuit layout shown in Figure 9-2 in the circuit design.**

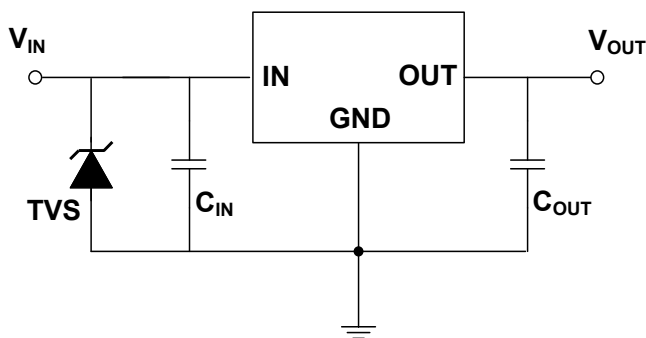

Figure 9-1. TVS is used at IN

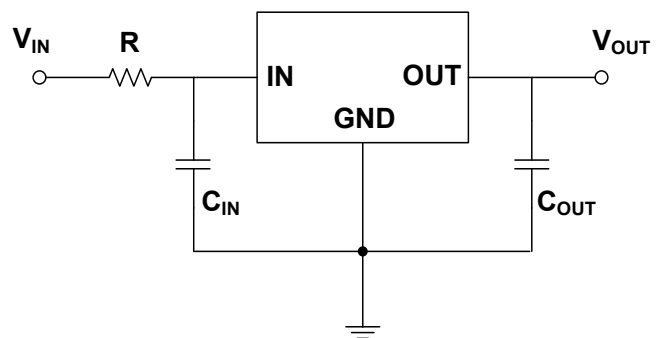

Figure 9-2. Resistance is used at IN

9 Application and Implementation

9.1 Risk Alert and Precautions (continued)

Large Output Capacitance

The CJ78L series can obtain better transient response with the help of output capacitance. However, if the output capacitor is relatively large, the surge current generated by the charging of the output capacitor will also be large at the moment of power on of the regulator, and the large surge current passing through the regulator may damage the internal circuit. When the output capacitance is large, adopting the circuit design shown in Figure 9-2 will reduce the possibility of damage to the device due to large surge current to a certain extent. It is recommended that the selection of output capacitor should not exceed 20 μ F. **If the selection of output capacitor exceeds 20 μ F, it is recommended to adopt the circuit design in Figure 9-2 to reduce the possibility of accidental failure of the device due to large surge current during power on.**

9.2 Application Information

Bypass Capacitance Selection

A capacitance between IN and GND (C_{IN}) is required if the regulator is located far from the power supply filter. It is recommended to use a 0.33 μ F capacitor for C_{IN} , and the capacitor (C_{IN}) should be placed as close to the device IN pin and GND pin as possible.

It is recommended to use a 0.1 μ F capacitor between OUT and GND (C_{OUT}), and the capacitor should be placed as close as possible between OUT and GND. The output capacitance can limit the high-frequency noise and help the device obtain the best stability and transient response.

The tolerance and temperature coefficient of the input and output capacitor (C_{IN} and C_{OUT}) must be considered to ensure that the capacitor can work normally within the rated working ambient temperature and rated working conditions of the equipment.

It is recommended that the output capacitor (C_{OUT}) should not exceed 20 μ F. When the output capacitor (C_{OUT}) exceeds 20 μ F, it is recommended to use the circuit layout shown in Figure 9-2. See *Large Output Capacitance* for more details.

Design Requirements and Procedure

The CJ78L series is mainly used to provide fixed output voltage regulation, the output voltage is selected based on the device variant, which is available in 5.0V, 6.0V, 8.0V, 9.0V, 12V and 15V regulator options, and it requires a very small number of equipment components. If the regulator is far from the power filter, the input capacitor C_{IN} is required. The bypass capacitor C_{OUT} is used at the output to obtain the best stability and transient response. These capacitors must be as close to the regulator as possible. The simplest implementation of the CJ78L series is shown in Figure 9-3.

9 Application and Implementation

9.3 System Example

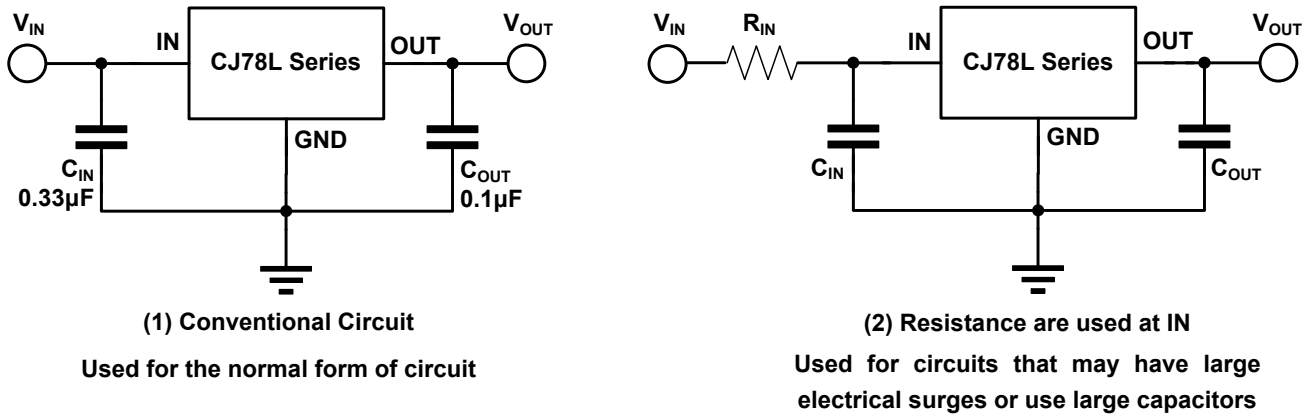

Figure 9-3. Fixed Output Regulator

Note: For more details, see the part *Risk Alert and Precautions*.

9.4 Power Supply Recommendation

The linear regulator input supply must be well regulated and kept at a voltage level to not exceed the maximum input to output voltage differential allowed by the device. The minimum dropout voltage (V_{DO}) must be met with extra headroom when possible to keep the output well regulated.

For the best overall performance, some layout guidelines may be disregarded. Place all circuit components on the same side of the circuit board and as near as practical to the respective linear regulator pins. Traces must be kept short and wide to reduce the amount of parasitic elements in the system. The actual width and thickness of traces depends on the current carrying capability and heat dissipation required by the end system.

NOTE

The application information in this section is not part of the data sheet component specification, and JSCJ makes no commitment or statement to guarantee its accuracy or completeness. Customers are responsible for determining the rationality of corresponding components in their circuit design and making tests and verifications to ensure the normal realization of their circuit design.

10 Mechanical Information

10.1 SOT-23-3L Mechanical Information

SOT-23-3L Outlines Dimensions

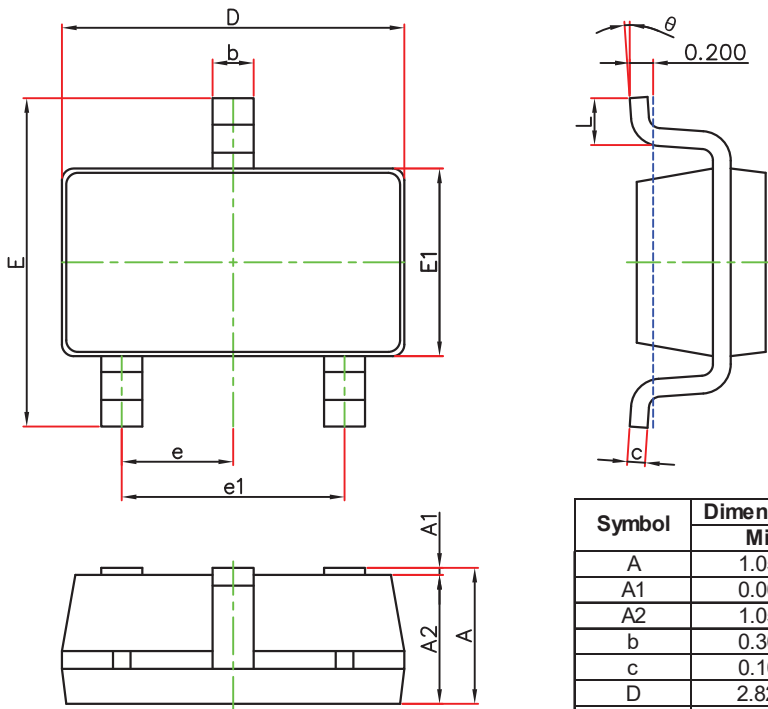

Symbol	Dimensions In Millimeters		Dimensions In Inches	
	Min.	Max.	Min.	Max.
A	1.050	1.250	0.041	0.049
A1	0.000	0.100	0.000	0.004
A2	1.050	1.150	0.041	0.045
b	0.300	0.500	0.012	0.020
c	0.100	0.200	0.004	0.008
D	2.820	3.020	0.111	0.119
E1	1.500	1.700	0.059	0.067
E	2.650	2.950	0.104	0.116
e	0.950(BSC)		0.037(BSC)	
e1	1.800	2.000	0.071	0.079
L	0.300	0.600	0.012	0.024
K	0°	8°	0°	8°

SOT-23-3L Suggested Pad Layout

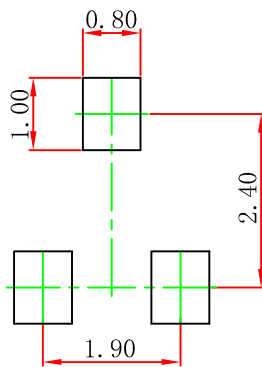

Note:

1. Controlling dimension: in millimeters.
2. General tolerance: ±0.05mm.
3. The pad layout is for reference purpose only.

10 Mechanical Information

10.2 SOT-89-3L Mechanical Information

SOT-89-3L Outlines Dimensions

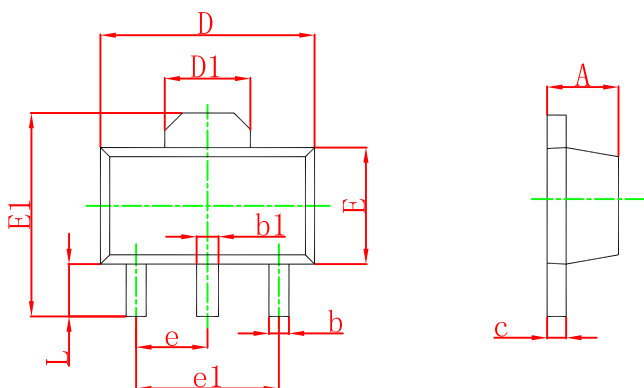

Symbol	Dimensions In Millimeters		Dimensions In Inches	
	Min	Max	Min	Max
A	1.400	1.600	0.055	0.063
b	0.320	0.520	0.013	0.020
b1	0.400	0.580	0.016	0.023
c	0.350	0.440	0.014	0.017
D	4.400	4.600	0.173	0.181
D1	1.550 REF.		0.061 REF.	
E	2.300	2.600	0.091	0.102
E1	3.940	4.250	0.155	0.167
e	1.500 TYP.		0.060 TYP.	
e1	3.000 TYP.		0.118 TYP.	
L	0.900	1.200	0.035	0.047

SOT-89-3L Suggested Pad Layout

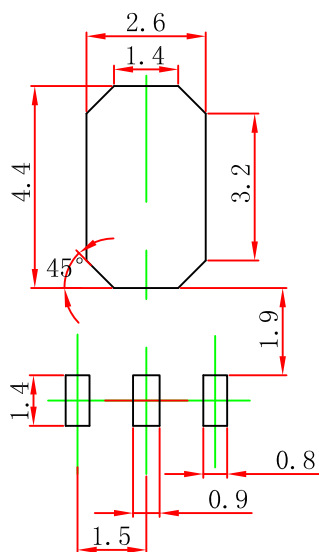

Note:

1. Controlling dimension: in millimeters.
2. General tolerance: $\pm 0.05\text{mm}$.
3. The pad layout is for reference purpose only.

10 Mechanical Information

10.3 TO-92 Mechanical Information

TO-92 Outlines Dimensions

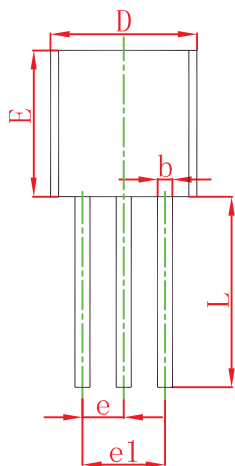
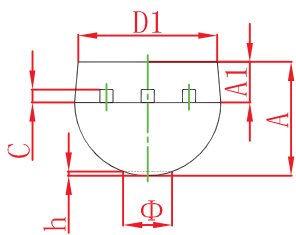

Symbol	Dimensions In Millimeters		Dimensions In Inches	
	Min	Max	Min	Max
A	3.300	3.700	0.130	0.146
A1	1.100	1.400	0.043	0.055
b	0.380	0.550	0.015	0.022
c	0.360	0.510	0.014	0.020
D	4.400	4.700	0.173	0.185
D1	3.430		0.135	
E	4.300	4.700	0.169	0.185
e	1.270 TYP		0.050 TYP	
e1	2.440	2.640	0.096	0.104
L	14.100	14.500	0.555	0.571
K		1.600		0.063
h	0.000	0.380	0.000	0.015

TO-92 Suggested Pad Layout

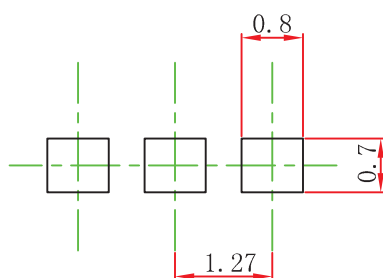

Note:

1. Controlling dimension: in millimeters.
2. General tolerance: ±0.05mm.
3. The pad layout is for reference purpose only.

11 Package Information

11.1 SOT-23-3L Tape and Reel Information

Embossed Carrier Tape

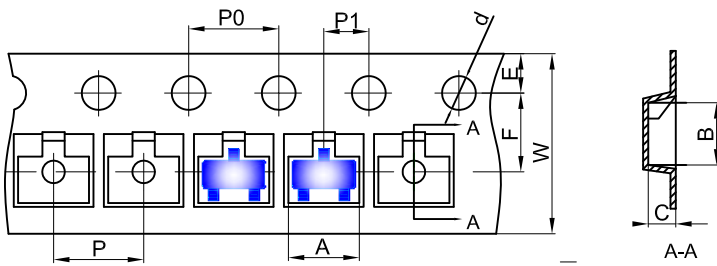

Packaging Description:

SOT-23-3L parts are shipped in tape. The carrier tape is made from a dissipative (carbon filled) polycarbonate resin. The cover tape is a multilayer film (Heat Activated Adhesive in nature) primarily composed of polyester film, adhesive layer, sealant, and anti-static sprayed agent. These reeled parts in standard option are shipped with 3,000 units per 7" or 18.0cm diameter reel. The reels are clear in color and is made of polystyrene plastic (anti-static coated).

Dimensions are in millimeter										
Pkg type	A	B	C	d	E	F	P0	P	P1	W
SOT-23-3L	3.18	3.28	1.32	Ø1.50	1.75	3.50	4.00	4.00	2.00	8.00

SOT-23-3L Tape Leader and Trailer

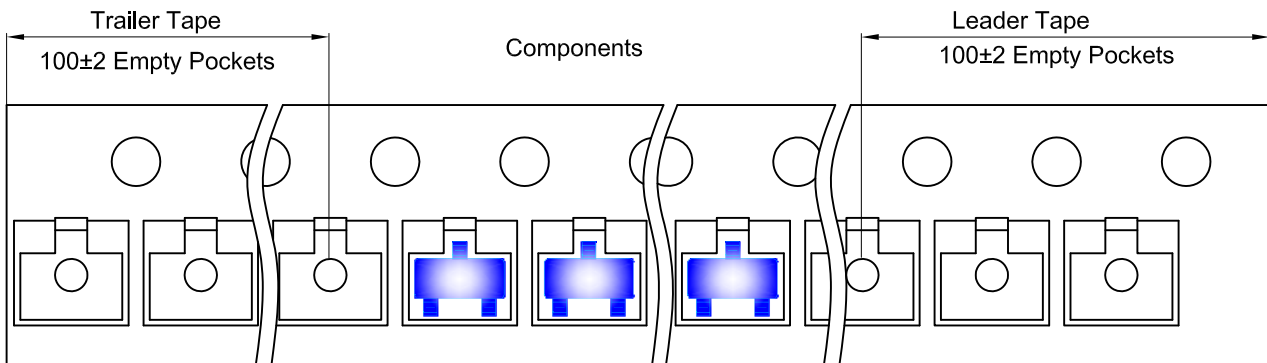

SOT-23-3L Reel

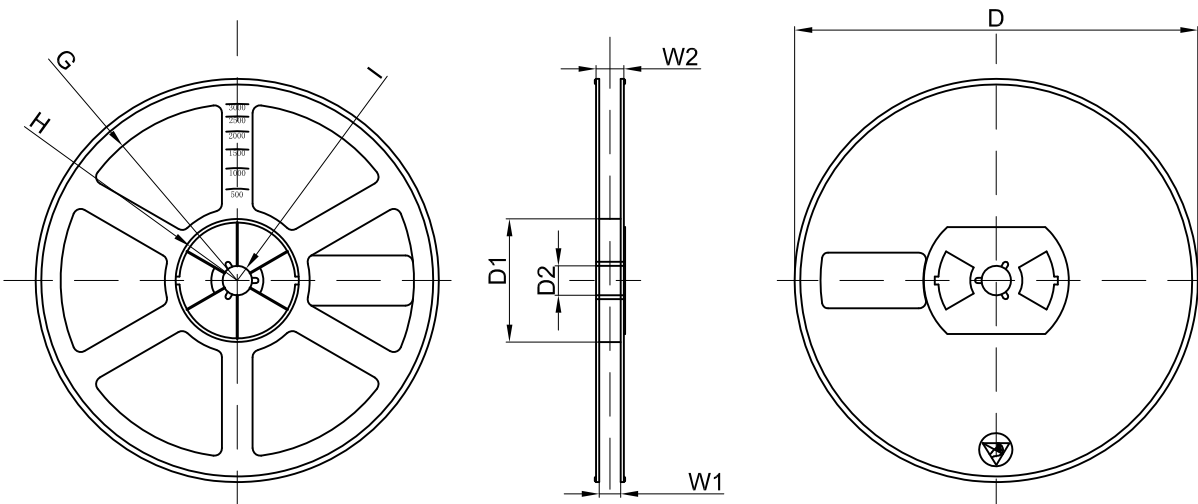

Dimensions are in millimeter								
Reel Option	D	D1	D2	G	H	I	W1	W2
7"Dia	Ø180.00	60.00	13.00	R78.00	R25.60	R6.50	9.50	13.10

REEL	Reel Size	Box	Box Size(mm)	Carton	Carton Size(mm)	G.W.(kg)
3000 pcs	7 inch	30,000 pcs	203×203×195	120,000 pcs	438×438×220	

11 Package Information

11.2 SOT-89-3L Tape and Reel Information

Embossed Carrier Tape

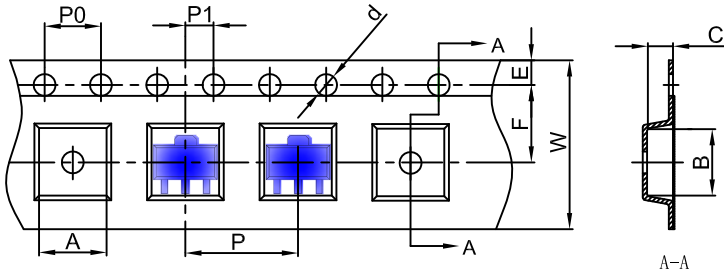

Packaging Description:
 SOT-89-3L parts are shipped in tape. The carrier tape is made from a dissipative (carbon filled) polycarbonate resin. The cover tape is a multilayer film (Heat Activated Adhesive in nature) primarily composed of polyester film, adhesive layer, sealant, and anti-static sprayed agent. These reeled parts in standard option are shipped with 1,000 units per 7" or 18.0 cm diameter reel. The reels are clear in color and is made of polystyrene plastic (anti-static coated).

Dimensions are in millimeter										
Pkg type	A	B	C	d	E	F	P0	P	P1	W
SOT-89-3L	4.85	4.45	1.85	Ø1.50	1.75	5.50	4.00	8.00	2.00	12.00

SOT-89-3L Tape Leader and Trailer

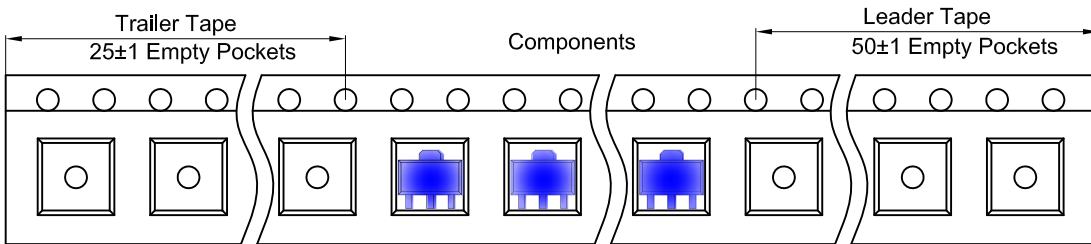

SOT-89-3L Reel

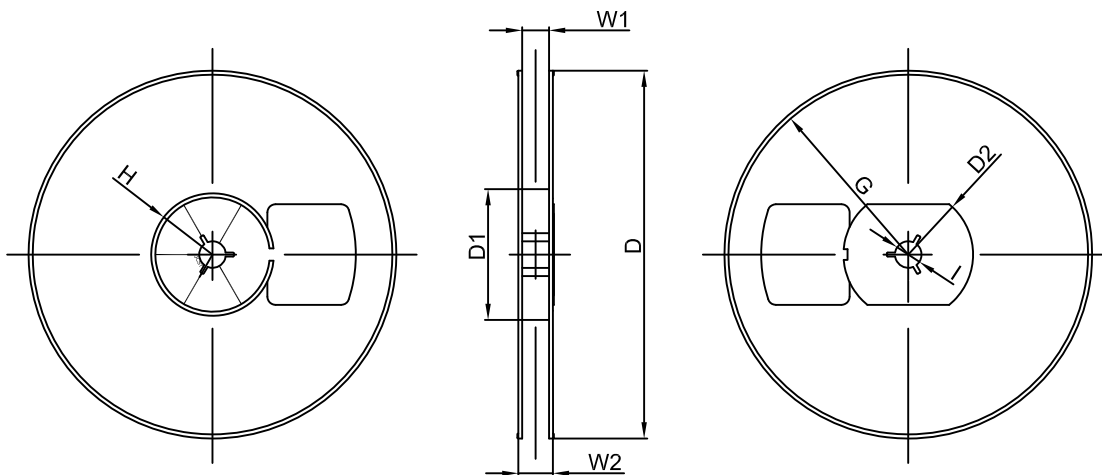

Dimensions are in millimeter								
Reel Option	D	D1	D2	G	H	I	W1	W2
7" Dia	Ø180.00	60.00	R32.00	R86.50	R30.00	Ø13.00	13.20	16.50

REEL	Reel Size	Box	Box Size(mm)	Carton	Carton Size(mm)	G.W.(kg)
1000 pcs	7 inch	10,000 pcs	203×203×195	40,000 pcs	438×438×220	

11 Package Information

11.3 TO-92 Tape and Reel Information

Embossed Carrier Tape

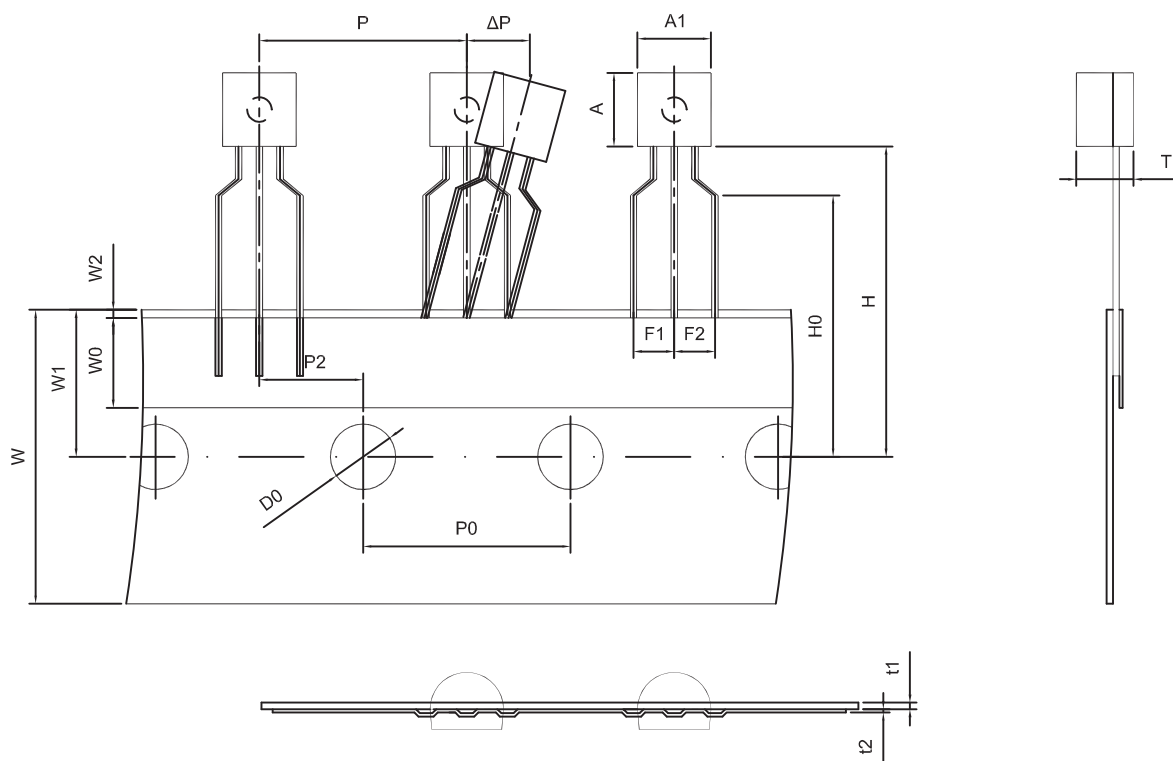

Dimiensions are in millimeter

A1	A	T	P	P0	P2	F1	F2	W
4.5	4.5	3.5	12.7	12.7	6.35	2.5	2.5	18.0
W0	W1	W2	H	H0	D0	t1	t2	ΔP
6.0	9.0	1.0 MAX.	19.0	16.0	4.0	0.4	0.2	0

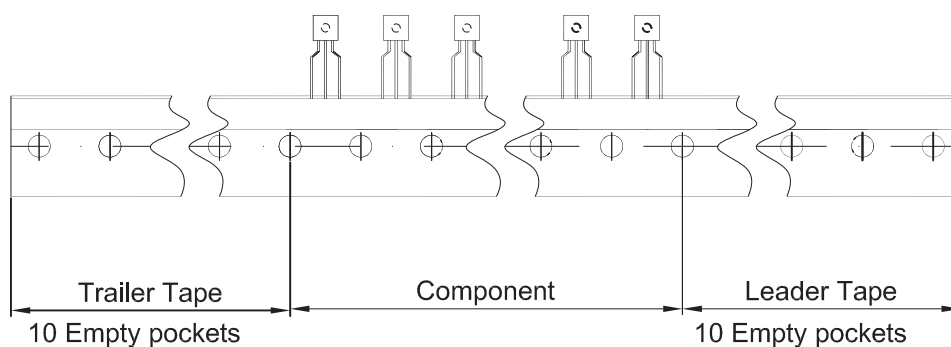

Package	Box	Box Size(mm)	Carton	Carton Size(mm)
TO-92	2000 pcs	333×162×43	20,000 pcs	350×340×250

12 Notes and Revision History

12.1 Associated Product Family and Others

To view other products of the same type or IC products of other types, please click the official website of JSCJ -- <https://www.jscj-elec.com> for more details.

12.2 Notes

Electrostatic Discharge Caution



This IC may be damaged by ESD. Relevant personnel shall comply with correct installation and use specifications to avoid ESD damage to the IC. If appropriate measures are not taken to prevent ESD damage, the hazards caused by ESD include but are not limited to degradation of integrated circuit performance or complete damage of integrated circuit. For some precision integrated circuits, a very small parameter change may cause the whole device to be inconsistent with its published specifications.

Junction-to-ambient Thermal Resistance $R_{\theta JA}$

Definition: The junction to ambient thermal resistance $R_{\theta JA}$ is a metric of the thermal performance of the device's packages. By comparing the metric of different companies on the same product package, the thermal performance of the product can be roughly estimated in a relative sense. $R_{\theta JA}$ is measured under the conditions specified in the corresponding specifications. If the measurement of $R_{\theta JA}$ of two products follows different specifications and standards, or although the same specifications and standards are adopted, it is not tested in strict accordance with the specifications, then the $R_{\theta JA}$ of two products will lose the meaning of comparison. This product follows the test specified by JEDEC in the EIA/JESD51-x series documents. $R_{\theta JA}$ is measured in still air with $T_A = 25^\circ\text{C}$ and installed on a 1 in 2 FR-4 board covered with 2 ounces of copper.

Usage: Junction to ambient thermal resistance $R_{\theta JA}$ is a parameter defined at the system level rather than on a single device or chip. In the test of $R_{\theta JA}$ provided in the data sheet, most of the heat generated by the operation of the device is dissipated through the test board rather than the packaging surface of the device. In fact, the design and layout of PCB (such as chip or pad size, internal package geometry, etc.) will significantly affect $R_{\theta JA}$. At this time, any calculation of the junction temperature or thermal power consumption of the device by applying $R_{\theta JA}$ in the data sheet will have a very large error, so that it does not match the real performance of the device.

Therefore, $R_{\theta JA}$ should be used as the relative comparison of product packaging thermal performance between different companies, rather than directly using $R_{\theta JA}$ in the data sheet in the actual calculation.

Reference Maximum Power Dissipation for Continuous Operation $P_{D Ref}$

The reference maximum power dissipation for continuous operation $P_{D Ref}$ is not an accurate value obtained from the actual test. It is a theoretical value obtained according to the heat dissipation capacity of packaging combined with practical application. It is used to compare the differences of heat dissipation capacity more intuitively between products of different companies. This value is only for estimation reference and cannot be used as an index of the actual performance of the device for circuit design.

12 Notes and Revision History

12.3 Revision History

September, 2022: updated CJ78L series, rev - 3.0:

Modified data sheet format:

All data sheet, added headers, changed font size;

Page 1, modified footer;

Assembled CJ78L05, CJ78L06, CJ78L08, CJ78L09, CJ78L12 and CJ78L15 devices into the CJ78L series;

Deleted obsolete CJ78L18 device from the data sheet;

Added Introduction, Available Package, Applications, Pin Configuration and Marking Information,

Recommended Operating Conditions, ESD Ratings, Thermal Information, Detailed Description,

Application and Implementation and Notes and Revision History sections;

DISCLAIMER, deleted the description of "automotive electronics".

DISCLAIMER

IMPORTANT NOTICE, PLEASE READ CAREFULLY

The information in this data sheet is intended to describe the operation and characteristics of our products. JSCJ has the right to make any modification, enhancement, improvement, correction or other changes to any content in this data sheet, including but not limited to specification parameters, circuit design and application information, without prior notice.

Any person who purchases or uses JSCJ products for design shall: 1. Select products suitable for circuit application and design; 2. Design, verify and test the rationality of circuit design; 3. Procedures to ensure that the design complies with relevant laws and regulations and the requirements of such laws and regulations. JSCJ makes no warranty or representation as to the accuracy or completeness of the information contained in this data sheet and assumes no responsibility for the application or use of any of the products described in this data sheet.

Without the written consent of JSCJ, this product shall not be used in occasions requiring high quality or high reliability, including but not limited to the following occasions: medical equipment, military facilities and aerospace. JSCJ shall not be responsible for casualties or property losses caused by abnormal use or application of this product.

Official Website: www.jscj-elec.com

Copyright © JIANGSU CHANGJING ELECTRONICS TECHNOLOGY CO., LTD.