

LMP92064 具有 SPI 接口的精密低侧 125kSps 同步采样 电流传感器和电压监视器

1 特性

- 2 个 12 位同步采样模数转换器 (ADC)
 - 转换速率: 125kSps (最小值)
- 12 位电流感测通道
 - 输入引入偏移电压: $\pm 15\mu\text{V}$
 - 共模电压范围: -0.2V 至 2V
 - 最大差分输入电压: 75mV
 - 固定增益: 25V/V
 - 增益误差: $\pm 0.75\%$ (最大值)
 - 带宽 (-3dB): 70kHz
 - 直流电源抑制比 (PSRR): 100dB
 - 直流共模抑制比 (CMRR): 110dB
- 12 位电压通道
 - 积分非线性 (INL): ± 1 最低有效位 (LSB)
 - 偏移误差: $\pm 2\text{mV}$ (最大值)
 - 增益误差: $\pm 0.75\%$ (最大值)
 - 最大输入电压: 2.048V
 - 带宽: 100kHz
- 内部基准电压
- 串行外设接口 (SPI) 频率: 高达 20MHz
- 温度范围: -40°C 至 105°C
- 16 引脚晶圆级小外形无引线 (WSON) 封装

2 应用

- 企业级服务器
- 电信
- 电源管理

3 说明

LMP92064 是一款具有数字 SPI 接口的精密低侧数字电流传感器和电压监视器。该模拟前端 (AFE) 包括一个精密电流感测放大器和一个缓冲电压通道, 分别用于测量分流电阻的负载电流和负载的供电电压。该器件通过独立的 125kSps 、12 位 ADC 转换器对电流和电压通道进行同步采样, 以在单向感测应用中实现极为精确的功率计算。

LMP92064 为 ADC 提供了 2.048V 内部基准电压, 不仅消除了对外部基准电压的需求, 同时还减少了元件数量并节省了电路板空间。

主机可通过四线 SPI 接口以高达 20MHz 的运行速度与 LMP92064 通信。凭借这一快速的 SPI 接口, 用户能够利用较高带宽 ADC 来捕获快速变化的信号。此外, 该四线接口还具有专用单向输入和输出线, 这使得需要隔离的应用能够轻松连接数字隔离器。

LMP92064 由 4.5V 至 5.5V 的单电源供电运行, 并且具有一个独立的数字电源引脚。LMP92064 采用 16 引脚 $5\text{mm} \times 4\text{mm}$ WSON 封装, 额定温度范围为 -40°C 至 105°C 。

器件信息⁽¹⁾

器件型号	封装	封装尺寸 (标称值)
LMP92064	WSON (16)	$5.00\text{mm} \times 4.00\text{mm}$

(1) 如需了解所有可用封装, 请见数据表末尾的可订购产品附录。

简化电路原理图

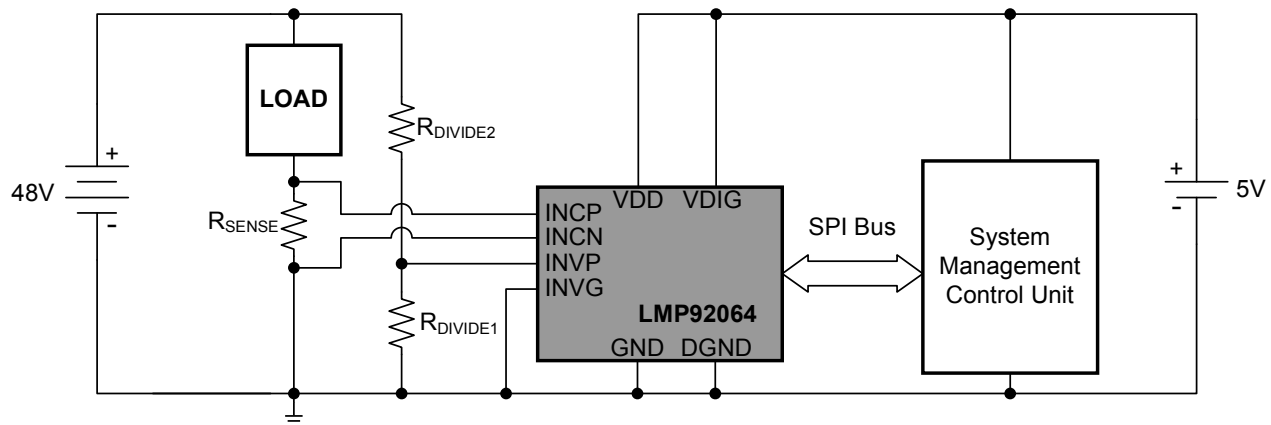

目录

1	特性	1	7.3	Feature Description	10
2	应用	1	7.4	Device Functional Modes	11
3	说明	1	7.5	Register Maps	13
4	修订历史记录	2	8	Application and Implementation	17
5	Pin Configuration and Functions	3	8.1	Application Information	17
6	Specifications	4	8.2	Typical Application	17
6.1	Absolute Maximum Ratings	4	9	Power Supply Recommendations	21
6.2	ESD Ratings	4	10	Layout	21
6.3	Recommended Operating Conditions	4	10.1	Layout Guidelines	21
6.4	Thermal Information	4	10.2	Layout Example	22
6.5	Electrical Characteristics	5	11	器件和文档支持	23
6.6	Timing Requirements	6	11.1	商标	23
6.7	Typical Characteristics	7	11.2	静电放电警告	23
7	Detailed Description	10	11.3	术语表	23
7.1	Overview	10	12	机械、封装和可订购信息	23
7.2	Functional Block Diagram	10			

4 修订历史记录

Changes from Original (June 2013) to Revision A

Page

- 已添加 引脚配置和功能部分, ESD 额定值表, 特性描述部分, 器件功能模式, 应用和实施部分, 电源相关建议部分, 布局部分, 器件和文档支持部分以及机械、封装和可订购信息部分..... **1**

5 Pin Configuration and Functions

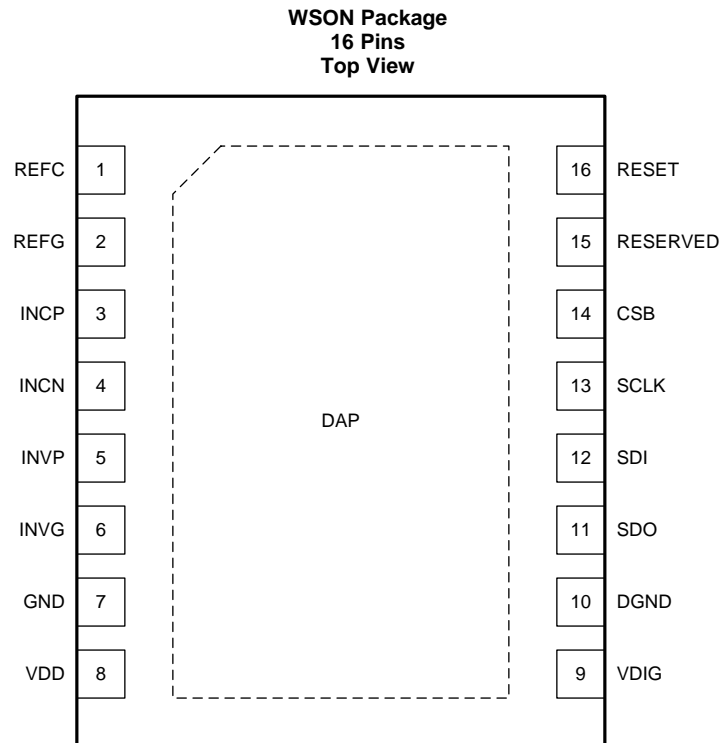

Pin Functions

PIN		I/O ⁽¹⁾	DESCRIPTION
NAME	NO.		
REFC	1	—	Internal reference bypass capacitor pin
REFG	2	G	Internal reference ground
INCP	3	I	Positive current channel input
INCN	4	I	Negative current channel input
INVP	5	I	Positive voltage channel input
INVG	6	G	Ground reference for the negative voltage channel input
GND	7	G	Analog ground
VDD	8	P	Analog power supply
VDIG	9	P	Digital power supply
DGND	10	G	Digital ground
SDO	11	O	SPI Bus push-pull serial data digital output
SDI	12	I	SPI Bus serial data digital input
SCLK	13	I	SPI Bus clock digital input
CSB	14	I	SPI Bus chip select bar digital input
RESERVED	15	—	Reserved (Do not connect)
RESET	16	I	Reset (high-active)
DAP	n/a	—	No connection (Do not connect)

(1) G = Ground, I = Input, O = Output, P = Power

6 Specifications

6.1 Absolute Maximum Ratings⁽¹⁾

over operating free-air temperature range (unless otherwise noted)⁽²⁾

		MIN	MAX	UNIT
Analog Supply Voltage (VDD)		-0.3	6.0	V
Digital Supply Voltage (VDIG)		VDD-0.3	VDD+0.3	
Voltage at Input Pins ⁽³⁾		-0.3	VDD+0.3	V
Junction Temperature			150	°C
Mounting temperature	Infrared or convection (20 sec)		260	°C
Storage temperature, T _{stg}		-65	150	°C

- (1) All voltages are measured with respect to GND = DGND = 0 V, unless otherwise specified.
- (2) Stresses beyond those listed under *Absolute Maximum Ratings* may cause permanent damage to the device. These are stress ratings only, which do not imply functional operation of the device at these or any other conditions beyond those indicated under *Recommended Operating Conditions*. Exposure to absolute-maximum-rated conditions for extended periods may affect device reliability.
- (3) When the input voltage (VIN), at any pin exceeds power supplies (VIN < GND or VIN > VDD), the current at that pin must not exceed 5 mA, and the voltage (VIN) at that pin must not exceed 6.0 V. See *Pin Description* for additional details of input circuitry.

6.2 ESD Ratings

		VALUE	UNIT
V _(ESD) Electrostatic discharge	Human-body model (HBM), per ANSI/ESDA/JEDEC JS-001 ⁽¹⁾	±2000	V
	Charged-device model (CDM), per JEDEC specification JESD22-C101 ⁽²⁾	±1000	

- (1) JEDEC document JEP155 states that 500-V HBM allows safe manufacturing with a standard ESD control process.
- (2) JEDEC document JEP157 states that 250-V CDM allows safe manufacturing with a standard ESD control process.

6.3 Recommended Operating Conditions⁽¹⁾

over operating free-air temperature range (unless otherwise noted)

		MIN	MAX	UNIT
Analog Supply Voltage (VDD)		4.5	5.5	V
Digital Supply Voltage (VDIG)		VDD	VDD	V
Temperature Range		-40	105	°C

- (1) All voltages are measured with respect to GND = DGND = 0 V, unless otherwise specified.

6.4 Thermal Information

Over operating free-air temperature range (unless otherwise noted)

THERMAL METRIC ⁽¹⁾		LMP92064	UNIT
		NHR	
		16 PINS	
R _{θJA}	Package thermal resistance ⁽²⁾	44	°C/W

- (1) For more information about traditional and new thermal metrics, see the *IC Package Thermal Metrics* application report, [SPRA953](#).
- (2) The package thermal impedance is calculated in accordance with JESD 51-7. The maximum power dissipation must be de-rated at elevated temperatures and is dictated by T_{J(MAX)}, θ_{JA}, and the ambient temperature, T_A. The maximum allowable power dissipation P_{DMAX} = (T_{J(MAX)} - T_A) / θ_{JA} or the number given in *Absolute Maximum Ratings*, whichever is lower.

6.5 Electrical Characteristics

Typical specifications are at 25°C. All specifications are at $4.5\text{ V} \leq \text{VDD} \leq 5.5\text{ V}$, $\text{VDIG} = \text{VDD}$ and $-0.2\text{ V} \leq \text{VCM} \leq 2\text{ V}$, unless otherwise specified.

PARAMETER		TEST CONDITIONS	MIN	TYP	MAX	UNIT
CURRENT SENSE INPUT CHANNEL						
V_{OS}	Input-referred Offset Voltage			±15		μV
		Temperature extremes	-60		60	
TCV_{OS}	Input-referred Offset Voltage Drift			±280		nV/°C
	Long-term Stability			0.3		μV/mo
	Resolution			12 20		Bits μV
INL	Integral Non-Linearity Error			±1% ±0.025%		LSB
DNL	Differential Non-Linearity Error			±0.5		LSB
DC CMRR	Common-Mode Rejection Ratio	$-0.2\text{ V} \leq \text{VCM} \leq 2\text{ V}$		110		dB
DC PSRR	Power Supply Rejection Ratio	$4.5\text{ V} \leq \text{VDD} \leq 5.5\text{ V}$		100		dB
CMVR	Common-Mode Voltage Range	Low VCM		-0.2		V
		High VCM		2		
$V_{DIFF(MAX)}$	Maximum Differential Input Voltage Range			75		mV
A_V	Current Shunt Amplifier Gain			25		V/V
	Current Sense Channel Gain			50		kCode/V
GE	Gain Error (CSA, VREF and ADC)	Temperature extremes	-0.75%		0.75 %	
GD	Gain Drift			±25		ppm/°C
RIN	Input Impedance			100		GΩ
BW	-3dB Bandwidth			70		kHz
VOLTAGE INPUT CHANNEL						
	Offset Error (Buffer and ADC)	Temperature extremes	-2		2	mV
	Resolution			12		Bits
INL	Integral Non-Linearity Error			±1% ±0.025%		LSB
DC PSRR	Power Supply Rejection Ratio			70		dB
V_{CHVP}	Full-Scale Input Voltage			2.048		V
A_V	Buffer Amplifier Gain			1		V/V
	Voltage Sense Channel Gain			2		kCode/V
GE	Gain Error (Buffer, VREF and ADC)	Temperature extremes	-0.75%		0.75 %	
RIN	Input Impedance			100		GΩ
BW	Bandwidth ⁽¹⁾			100		kHz
DIGITAL INPUT/OUTPUT CHARACTERISTICS						
V_{IH}	Logical "1" Input Voltage	Temperature extreme	0.7*VDIG			V
V_{IL}	Logical "0" Input Voltage	Temperature extreme		0.3*VDIG		V
V_{OH}	Logical "1" Output Voltage	$I_{SOURCE} = 300\text{ }\mu\text{A}$				V
		Temperature extreme	VDIG -0.15			
V_{OL}	Logical "0" Output Voltage	$I_{SINK} = 300\text{ }\mu\text{A}$				V
		Temperature extreme			DGND +0.15	
SUPPLY CHARACTERISTICS						
I_{VDD}	Analog Supply Current			11		mA
I_{VDIG}	Digital Supply Current			2		mA

(1) No analog filter; limited by sampling rate.

6.6 Timing Requirements

Typical specifications are at 25°C. All specifications are at $4.5\text{ V} \leq V_{DD} \leq 5.5\text{ V}$, $V_{DIG} = V_{DD}$ and a 20 pF capacitive load on SDO, unless otherwise specified.

		MIN	MAX	UNIT
t_{DS}	SDI to SCLK rising edge setup time	10		ns
t_{DH}	SCLK rising edge to SDI hold time	10		ns
f_{CLK}	Frequency of SCLK	100		Hz
			20	MHz
t_{HIGH}	High width of SPI clock	25		ns
t_{LOW}	Low width of SPI clock	25		ns
t_S	CSB falling edge to SCLK rising edge setup time	10		ns
t_C	SCLK rising edge to CSB rising edge hold time	30		ns
t_{DV}	SCLK falling edge to valid SDO readback data		20	ns
t_{RST}	Reset pin pulse width	3.5		ns
t_{CONV}	Conversion rate of all channels	125		kSps

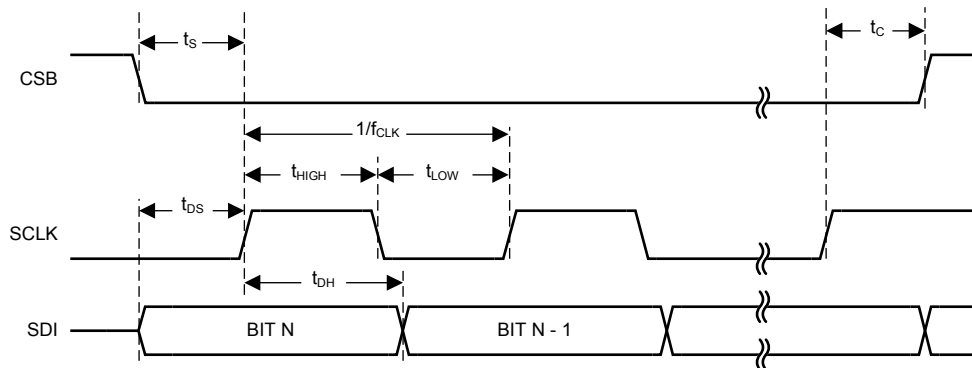

Figure 1. Serial Control Port Timing – Write

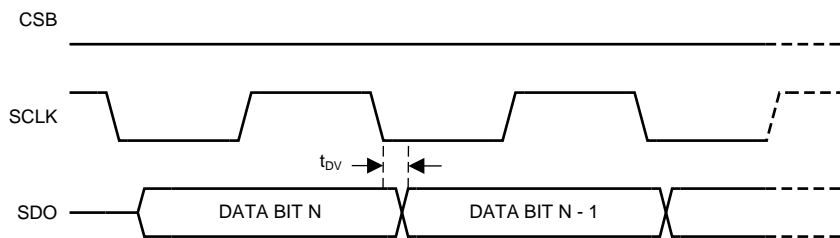

Figure 2. Serial Control Port Timing – Read

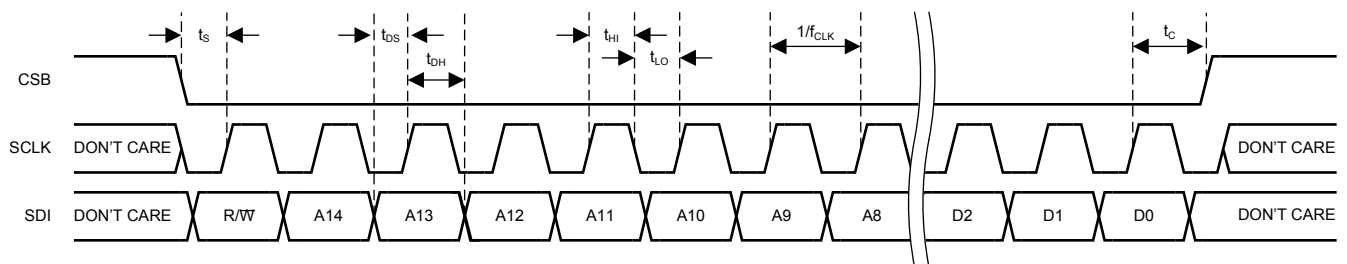

Figure 3. Serial Control Port Write – MSB First, 16-Bit Instruction, Timing Measurements

6.7 Typical Characteristics

All plots at $T_A = 25^\circ\text{C}$, $V_{DD} = 5.0\text{ V}$, $V_{DIG} = 5.0\text{ V}$, $V_{CM} = 0\text{ V}$ and $GND = DGND = 0\text{ V}$, unless otherwise specified.

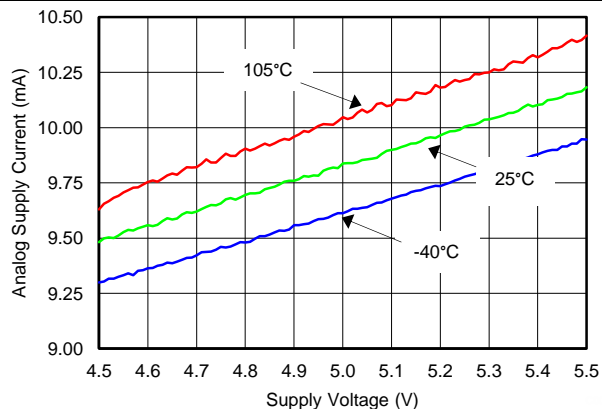

Figure 4. Analog Supply Current vs Supply Voltage

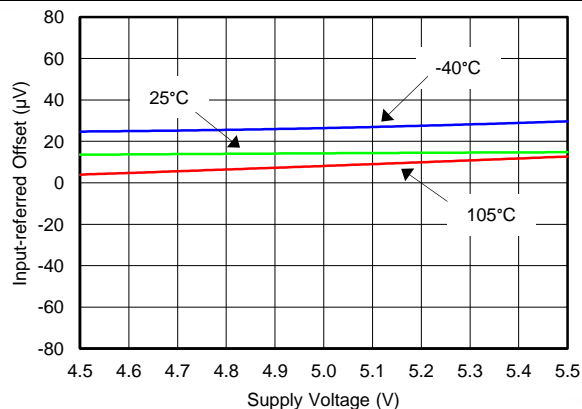

Figure 5. Input-Referred Offset vs Supply Voltage (Current Channel)

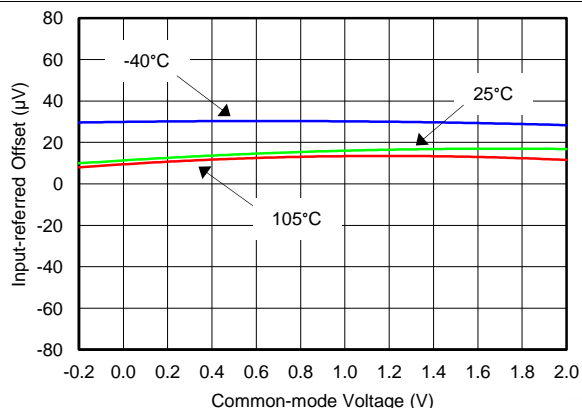

Figure 6. Input-Referred Offset vs Common-Mode Voltage (Current Channel)

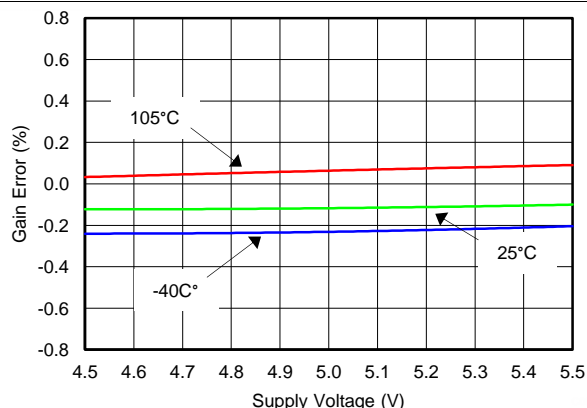

Figure 7. Gain Error vs Supply Voltage (Current Channel)

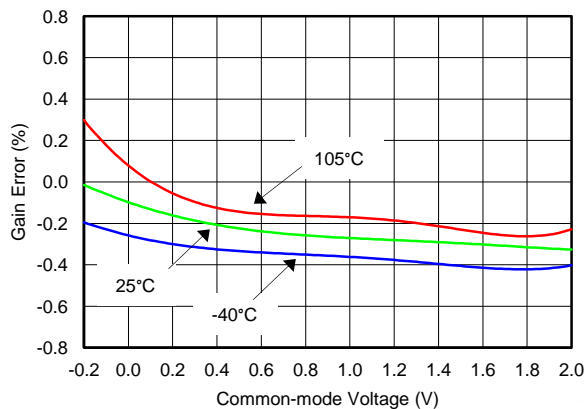

Figure 8. Gain Error vs Common-Mode Voltage (Current Channel)

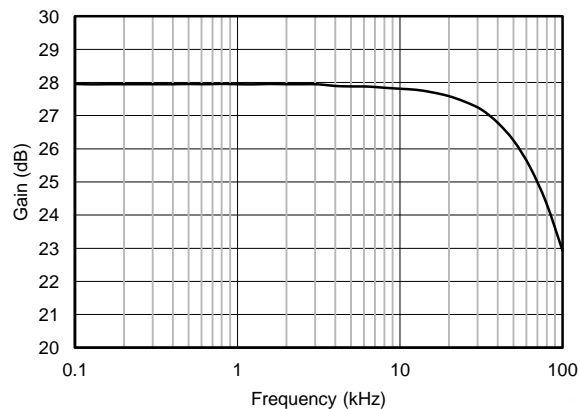

Figure 9. Gain vs Frequency (Current Channel)

Typical Characteristics (continued)

All plots at $T_A = 25^\circ\text{C}$, $V_{DD} = 5.0\text{ V}$, $V_{DIG} = 5.0\text{ V}$, $V_{CM} = 0\text{ V}$ and $GND = DGND = 0\text{ V}$, unless otherwise specified.

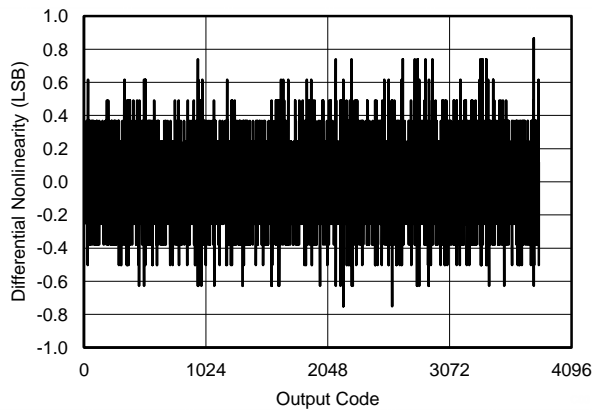

Figure 10. Differential Nonlinearity (Current Channel)

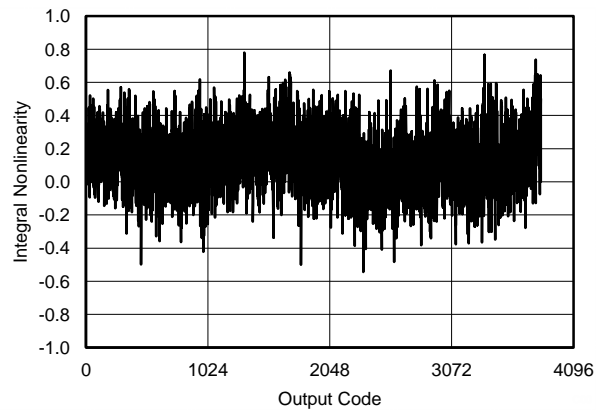

Figure 11. Integral Nonlinearity (Current Channel)

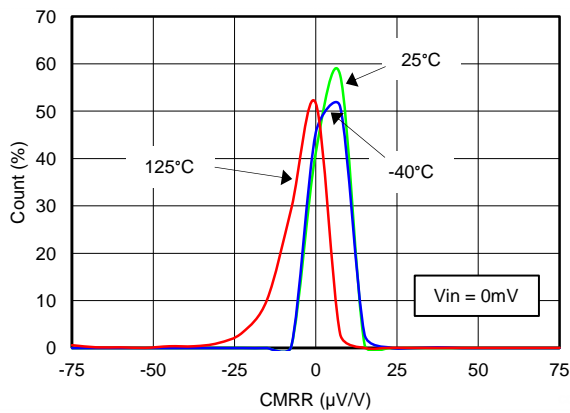

Figure 12. Common-Mode Rejection Ratio Distribution (Current Channel)

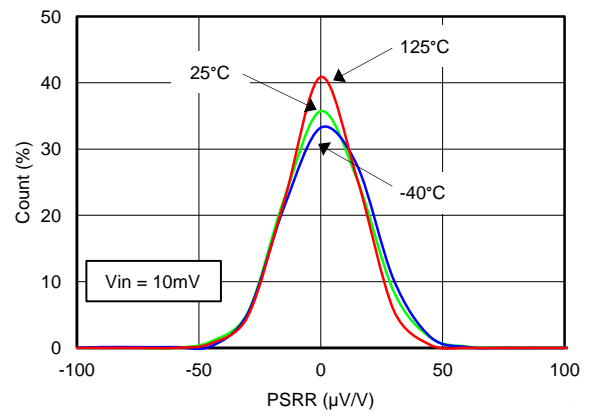

Figure 13. Power Supply Rejection Ratio Distribution $V_{cm} = -0.2\text{ V}$ (Current Channel)

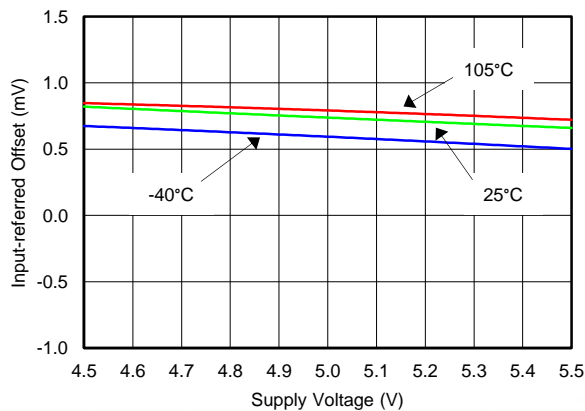

Figure 14. Input-Referred Offset V_{supply} Voltage (Voltage Channel)

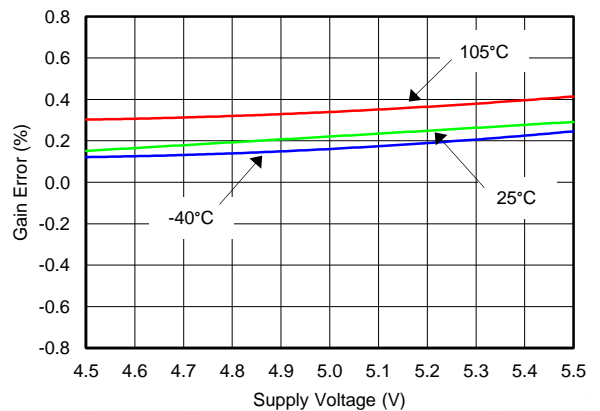

Figure 15. Gain Error vs Supply Voltage (Voltage Channel)

Typical Characteristics (continued)

All plots at $T_A = 25^\circ\text{C}$, $V_{DD} = 5.0\text{ V}$, $V_{DIG} = 5.0\text{ V}$, $V_{CM} = 0\text{ V}$ and $GND = DGND = 0\text{ V}$, unless otherwise specified.

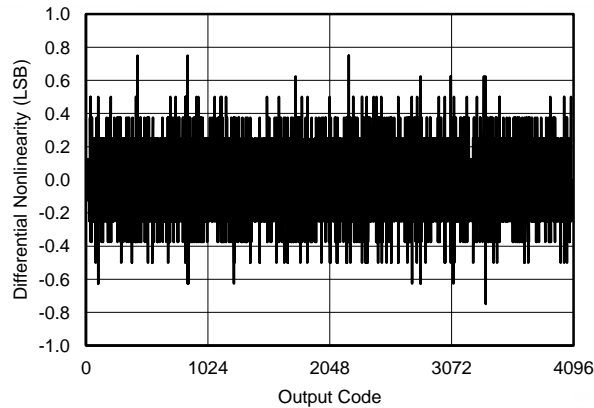

Figure 16. Differential Nonlinearity (Voltage Channel)

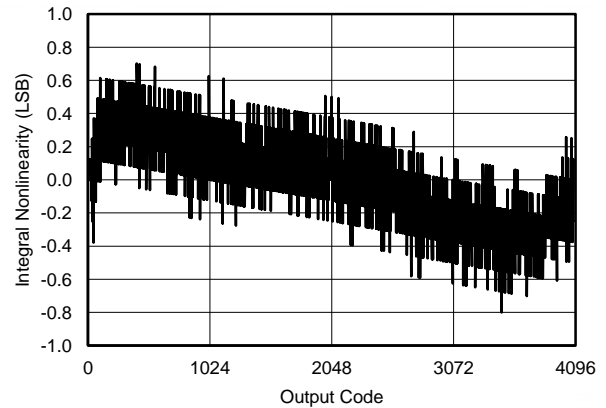

Figure 17. Integral Nonlinearity (Voltage Channel)

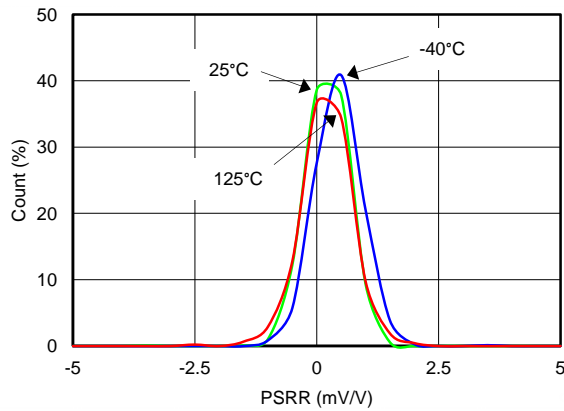

Figure 18. Power Supply Rejection Ratio Distribution (Voltage Channel)

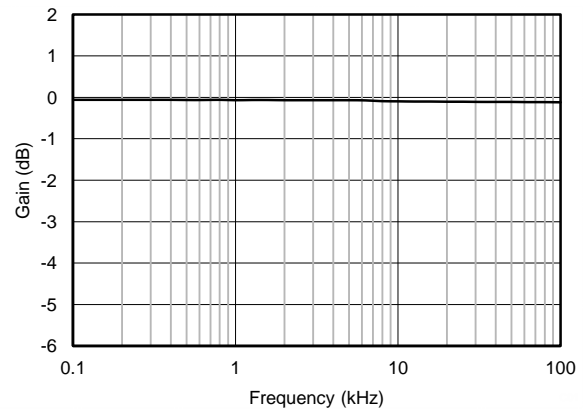

Figure 19. Gain vs Frequency (Voltage Channel)

7 Detailed Description

7.1 Overview

The LMP92064 is a precision low-side digital current sensor and voltage monitor with a digital SPI interface. The analog front-end includes a precision current sense amplifier to measure a load current across a shunt resistor and a buffered voltage channel to measure the voltage supply of the load.

7.2 Functional Block Diagram

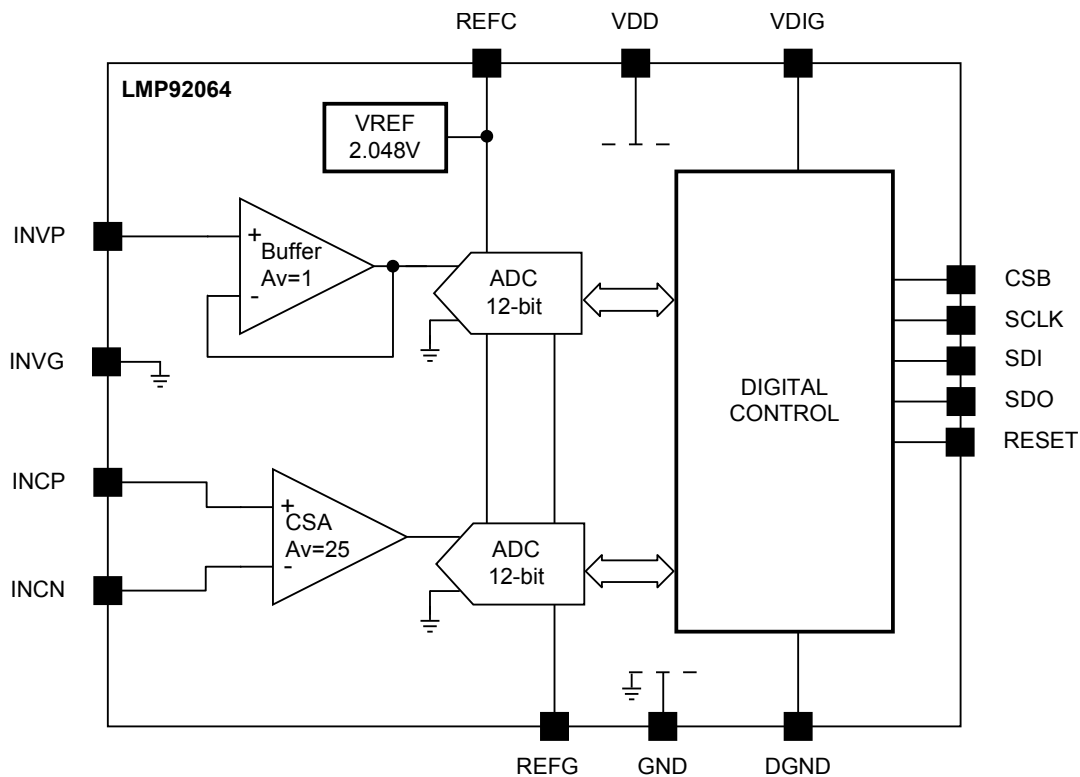

7.3 Feature Description

7.3.1 Current Sense Input Channel

The current sensing channel of the LMP92064 has a high impedance differential amplifier followed by a 12-bit analog-to-digital converter. The binary code result of a conversion is stored as a right-justified 16-bit number as shown in [Table 1](#), where the 4 most significant bits are always 0. Due to an offset auto-calibration feature of the current sense channel path, the top 256 codes are clipped at code 3840, denoted by the trailing zeros found in the equivalent binary code of the maximum positive input voltage.

The output data of the current sense channel is accessible on registers [0x0203](#) and [0x0202](#).

Table 1. Ideal Current Channel Input Voltages and Output Codes

DESCRIPTION	ANALOG VALUE	DIGITAL OUTPUT	
		BINARY CODE [B15:B0]	HEX CODE
Full scale range	$V_{FS} = 81.92 \text{ mV}$		
Least significant bit (LSB)	$V_{FS} / 4096$		
Maximum Positive Input Voltage	$V_{FS} - 256 \text{ LSB}$	0000 1111 0000 0000	0x0F00
Zero	0 V	0000 0000 0000 0000	0x0000

7.3.2 Current Sense Input Channel Common-Mode and Differential Voltage Range (Dynamic Range Considerations)

The input voltage should be in the range of -0.2 V to 2 V . The input can withstand voltage up to $V_{DD} + 0.3\text{ V}$ absolute maximum but the operational range is limited to 2 V . Operation below -0.2 V or above 2 V on either input pin will introduce severe gain errors and nonlinearity.

The maximum differential voltage (defined as the voltage difference between INCP and INCN) for which the part is designed to work is 75 mV . Larger differential or common mode input voltages will not damage the part (as long as the input pins remain between $GND - 0.3\text{ V}$ and $V_{DD} + 0.3\text{ V}$), however, exposure for extended periods may affect device reliability. The ADC output code will not roll over and will clip at minimum or maximum scale when the maximum differential voltage is exceeded.

7.3.3 Voltage Sense Input Channel

The voltage sensing channel of the LMP92064 has a high impedance buffer amplifier followed by a 12-bit analog-to-digital converter. The binary code result of a conversion is also stored as a right-justified 16-bit number as shown in [Table 2](#), where the 4 most significant bits are always 0.

The output data of the voltage sense channel is accessible on registers [0x0201](#) and [0x0200](#).

Table 2. Ideal Voltage Channel Input Voltages and Output Codes

DESCRIPTION	ANALOG VALUE	DIGITAL OUTPUT	
		BINARY CODE [B15:B0]	HEX CODE
Full scale range	$V_{FS} = 2.048\text{ V}$		
Least significant bit (LSB)	$V_{FS} / 4096$		
Maximum Positive Input Voltage	$V_{FS} - 1\text{ LSB}$	0000 1111 1111 1111	0x0FFF
Zero Code Voltage	0 V	0000 0000 0000 0000	0x0000

7.3.4 Reference

The LMP92064 includes an internal 2.048-V band-gap reference for the ADCs, which eliminates the need of an external reference and reduces component count and board space. The REFC pin is provided to allow bypassing this internal reference for low noise operation. A $1\text{-}\mu\text{F}$ ceramic decoupling capacitor is required between the REFC and REFG pins of the converter. The capacitor should be placed as close as possible to the pins of the device.

7.3.5 Reset

There are two methods to reset the LMP92064. A soft reset is done by setting bit7=1 in the [CONFIG_A](#) register. In a soft reset, the SPI state machine and the contents of registers [0x0000](#) and [0x0001](#) are unaffected.

A hardware reset is done by connecting the RESET pin of the LMP92064 to VDIG. If the pin is driven by a switch or a GPIO, TI recommends adding an external RC filter to prevent reset glitches.

7.3.6 Device Power-Up Sequence

The sources providing power to the analog and digital supply pins of the LMP92064, V_{DD} and $VDIG$, must ramp up at the same time to have a proper power-on reset (POR) event. The easiest way to achieve it is to tie V_{DD} and $VDIG$ to the same power source using a star configuration.

7.4 Device Functional Modes

7.4.1 ADC Operation

The LMP92064 includes two 12-bit ADCs that are continuously running in the background. The device is configured, and data is read, using a four-wire SPI interface: CSB, SCLK, SDO and SDI. The device outputs its data on SDO, and the data for both channels is synchronized such that all data read would be from the same instant in time. New conversion data for both channels will only be made available after all registers are read in descending sequential order (addresses [0x0203](#)-[0x0200](#)). All registers must be read otherwise new conversion data will not be available. Three different output data formats are available as detailed in [Figure 20](#), [Figure 21](#) and [Figure 22](#).

Device Functional Modes (continued)

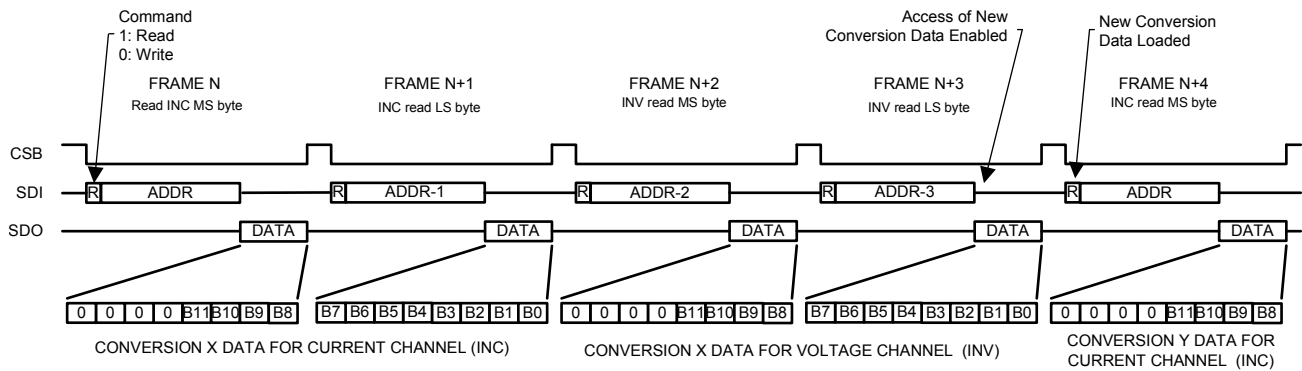

Figure 20. Timing Diagram With Byte Read Frames

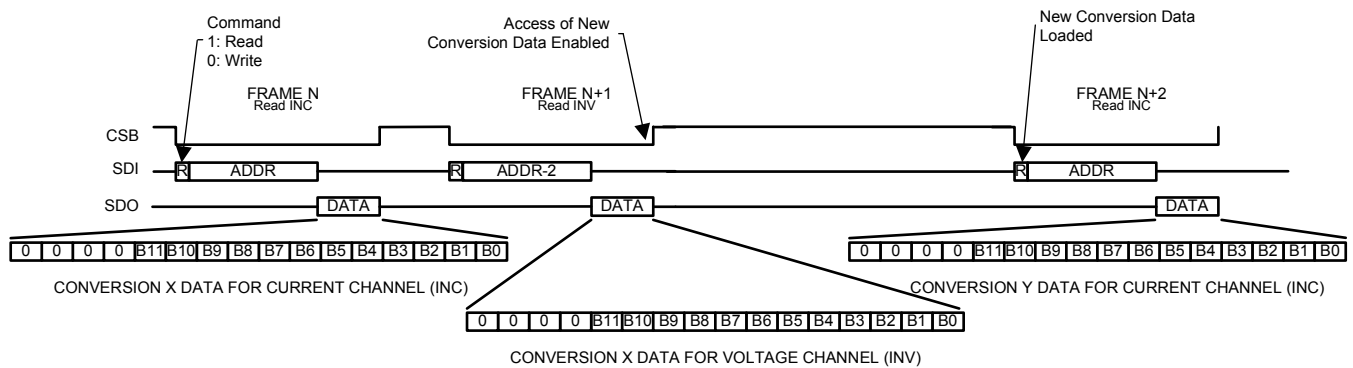

Figure 21. Timing Diagram With Word Read Frames

The register address to read can automatically decrement if the CSB line is kept low longer. For example, to read all the conversion data, keep the CSB line low for 48 SPI clock cycles (16 clocks for command/address, 8 clocks for MSB of current channel, 8 clocks for LSB of current channel, 8 clocks for MSB of voltage channel and 8 clocks for LSB of voltage channel). The read command should start from address 0x0203.

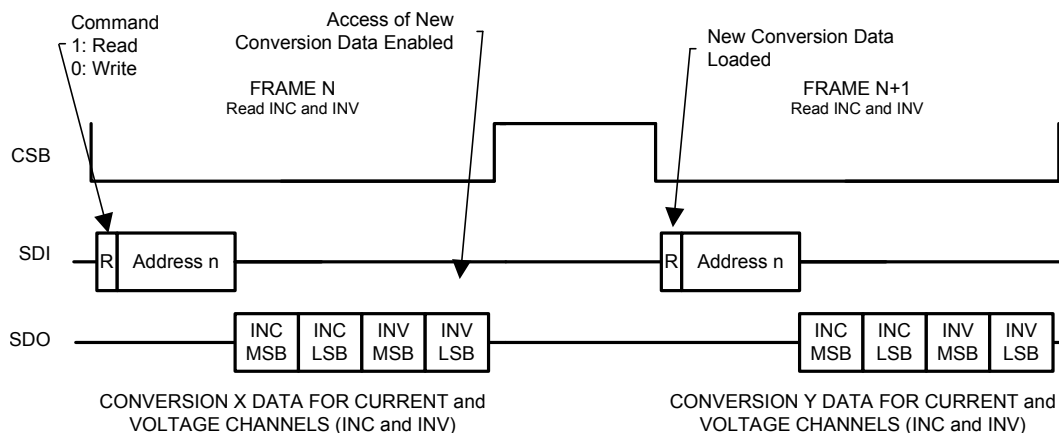

Figure 22. Timing Diagram With All Data Read Frames

7.5 Register Maps

1. If written to, Reserved bits must be written to 0, unless otherwise indicated.
2. Read back value of Reserved bits and registers is unspecified and should be discarded.
3. Recommended values must be programmed and forbidden values must not be programmed where they are indicated in order to avoid unexpected results.
4. If written to, registers indicated as Reserved must have the indicated default value as shown in the register map. Any other value can cause unexpected results.

Table 3. Register Map

REGISTER NAME	REGISTER DESCRIPTION	ADDRESS	ACCESS	DEFAULT
CONFIG_A	Interface Configuration A	0x0000	R/W	0x18
CONFIG_B	Interface Configuration B	0x0001	R/W	0x00
Reserved	Reserved	0x0002	R/W	0x00
CHIP_TYPE	Chip Type	0x0003	RO	0x07
CHIP_ID	Chip ID	0x0004 0x0005	RO	0x00 0x04
CHIP_REV	Chip Revision	0x0006	RO	0x01
MFR_ID	Manufacturer ID	0x000C 0x000D	RO	0x51 0x04
REG_UPDATE	Register Update	0x000F	R/W	0x00
CONFIG_REG	LMP92064 Specific Configuration Register	0x0100	R/W	0x00
STATUS	Status Register	0x0103	RO	N/A
DATA_VOUT	Voltage Channel Output Data	0x0200 0x0201	RO	N/A
DATA_COUT	Current Channel Output Data	0x0202 0x0203	RO	N/A

Table 4. CONFIG_A: Interface Configuration A

ADDR	BIT 7	BIT 6	BIT 5	BIT 4	BIT 3	BIT 2	BIT 1	BIT 0
0x0000	RESET	DDIR	ADDRDIR	SDDIR				

[7]	RESET ⁽¹⁾	Soft reset (self-clearing) 0: Normal (default) 1: Reset	R/W
[6]	DDIR	Data direction 0: Data is transmitted MSB first (default)	RO
[5]	ADDRDIR ⁽²⁾	Multiple-read auto-address direction 0: Address auto-decrements (default)	RO
[4]	SDDIR	Serial data direction 1: Unidirectional; SDI is used for write and SDO is used for read (default)	RO
[3:0]		Bits [3:0] should always mirror [7:4] as follows: [3] = [4] [2] = [5] [1] = [6] [0] = [7]	R/W

(1) Contents of register 0x0000 and 0x0001 and SPI state machine are unaffected

(2) Address 0x0000 will wrap to 0x7FFF

Table 5. CONFIG_B: Interface Configuration B

ADDR	BIT 7	BIT 6	BIT 5	BIT 4	BIT 3	BIT 2	BIT 1	BIT 0
0x0001	STREAM	Reserved	BUFREG_RD	Reserved		Reserved		Reserved

[7]	STREAM	Stream						RO
		0: Streaming is on (default)						
[6]	Reserved	Reserved						RO
		0 (default)						
[5]	BUFREG_RD ⁽¹⁾	Active/buffered register read-back						R/W
		0: Read back from active register (default)						
		1: Read back from buffered register						
[4:3]	Reserved	Reserved						RO
		00 (default)						
[2:1]	Reserved	Reserved						RO
		00 (default)						
[0]	Reserved	Reserved						RO
		0 (default)						

(1) Only double-buffered register affected: 0x0100

Table 6. CHIP_TYPE: Chip Type

ADDR	BIT 7	BIT 6	BIT 5	BIT 4	BIT 3	BIT 2	BIT 1	BIT 0
0x0003	CHIP_TYPE							

[7:0]	CHIP_TYPE	Chip type						RO
		0x07: Precision ADC						

Table 7. CHIP_ID: Chip ID LSB

ADDR	BIT 7	BIT 6	BIT 5	BIT 4	BIT 3	BIT 2	BIT 1	BIT 0
0x0004	CHIP_ID_LSB							

[7:0]	CHIP_ID_LSB	Chip ID LSB						RO
		0x00 (Manufacturer defined)						

Table 8. CHIP_ID: Chip ID MSB

ADDR	BIT 7	BIT 6	BIT 5	BIT 4	BIT 3	BIT 2	BIT 1	BIT 0
0x0005	CHIP_ID_MSB							

[7:0]	CHIP_ID_MSB	Chip ID MSB						RO
		0x04 (Manufacturer defined)						

Table 9. CHIP_REV: Chip Revision

ADDR	BIT 7	BIT 6	BIT 5	BIT 4	BIT 3	BIT 2	BIT 1	BIT 0
0x0006	CHIP_REV							

[7:0] CHIP_REV Chip REV RO
0x01

Table 10. MFR_ID: Manufacturer ID LSB

ADDR	BIT 7	BIT 6	BIT 5	BIT 4	BIT 3	BIT 2	BIT 1	BIT 0
0x000C	MFR_ID_LSB							

[7:0] MFR_ID_LSB Manufacturer ID LSB RO
0x51

Table 11. MFR_ID: Manufacturer ID MSB

ADDR	BIT 7	BIT 6	BIT 5	BIT 4	BIT 3	BIT 2	BIT 1	BIT 0
0x000D	MFR_ID_MSB							

[7:0] MFR_ID_MSB Manufacturer ID MSB RO
0x04

Table 12. REG_UPDATE: Register Update

ADDR	BIT 7	BIT 6	BIT 5	BIT 4	BIT 3	BIT 2	BIT 1	BIT 0
0x000F								BUFREG_UPDATE

[7:1] Reserved Reserved RO
0 (default)

[0] BUFREG_UPDATE⁽¹⁾ Buffered register update (self clearing) R/W
0: No action (default)
1: Transfer buffered register contents to active register

(1) Register 0x0100 is buffered.

Table 13. CONFIG_REG: Lmp92064 Specific Configuration Register

ADDR	BIT 7	BIT 6	BIT 5	BIT 4	BIT 3	BIT 2	BIT 1	BIT 0
0x0100	Reserved							

[7:0] Reserved⁽¹⁾ Reserved for future use R/W
0x00 (default)

(1) This register is double-buffered; register 0x000F must be set to 1 to transfer the contents from the buffer to the active register.

Table 14. STATUS: Status Register

ADDR	BIT 7	BIT 6	BIT 5	BIT 4	BIT 3	BIT 2	BIT 1	BIT 0
0x0103	0	0	0	0	0	0	0	STATUS

[7:1] Unused Unused RO
Always read 7'b0

[0] STATUS Status RO
0: Device is not ready for conversion
1: Device is ready for conversion

Table 15. DATA_VOUT: Voltage Channel Output Data LSB

ADDR	BIT 7	BIT 6	BIT 5	BIT 4	BIT 3	BIT 2	BIT 1	BIT 0
0x0200	VOUT_DATA_LSB							

[7:0] VOUT_ DATA_LSB Voltage output data least significant byte RO

Table 16. DATA_VOUT: Voltage Channel Output Data MSB

ADDR	BIT 7	BIT 6	BIT 5	BIT 4	BIT 3	BIT 2	BIT 1	BIT 0
0x0201	0	0	0	0	VOUT_DATA_MSB			

[7:4] Unused Unused RO
0000 (default)

[3:0] VOUT_ DATA_MSB Voltage output data most significant byte RO

Table 17. DATA_COUT: Current Channel Output Data LSB

ADDR	BIT 7	BIT 6	BIT 5	BIT 4	BIT 3	BIT 2	BIT 1	BIT 0
0x0202	COUT_DATA_LSB							

[7:0] COUT_ DATA_LSB Current output data least significant byte RO

Table 18. DATA_COUT: Current Channel Output Data MSB

ADDR	BIT 7	BIT 6	BIT 5	BIT 4	BIT 3	BIT 2	BIT 1	BIT 0
0x0203	0	0	0	0	COUT_DATA_MSB			

[7:4] Unused Unused RO
0000 (default)

[3:0] COUT_ DATA_MSB Current output data most significant byte RO

8 Application and Implementation

NOTE

Information in the following applications sections is not part of the TI component specification, and TI does not warrant its accuracy or completeness. TI's customers are responsible for determining suitability of components for their purposes. Customers should validate and test their design implementation to confirm system functionality.

8.1 Application Information

The LMP92064 is a precision low-side digital current sensor and voltage monitor with a digital SPI interface. The device is typically used to measure a load current by means of a current sense resistor connected in series with a load. Use the following design procedure to select the main components of a simple current and voltage monitoring application using the LMP92064.

8.2 Typical Application

In this example, the LMP92064 is used to sense the load current flowing through the sense resistor, R1. Additionally, the voltage across R3 can be sensed to calculate the bus voltage.

The load that will be monitored is operating from a -48-V bus. Because the GND pin of the LMP92064 is connected to the -48-V bus, -48 V becomes the ground reference for the device.

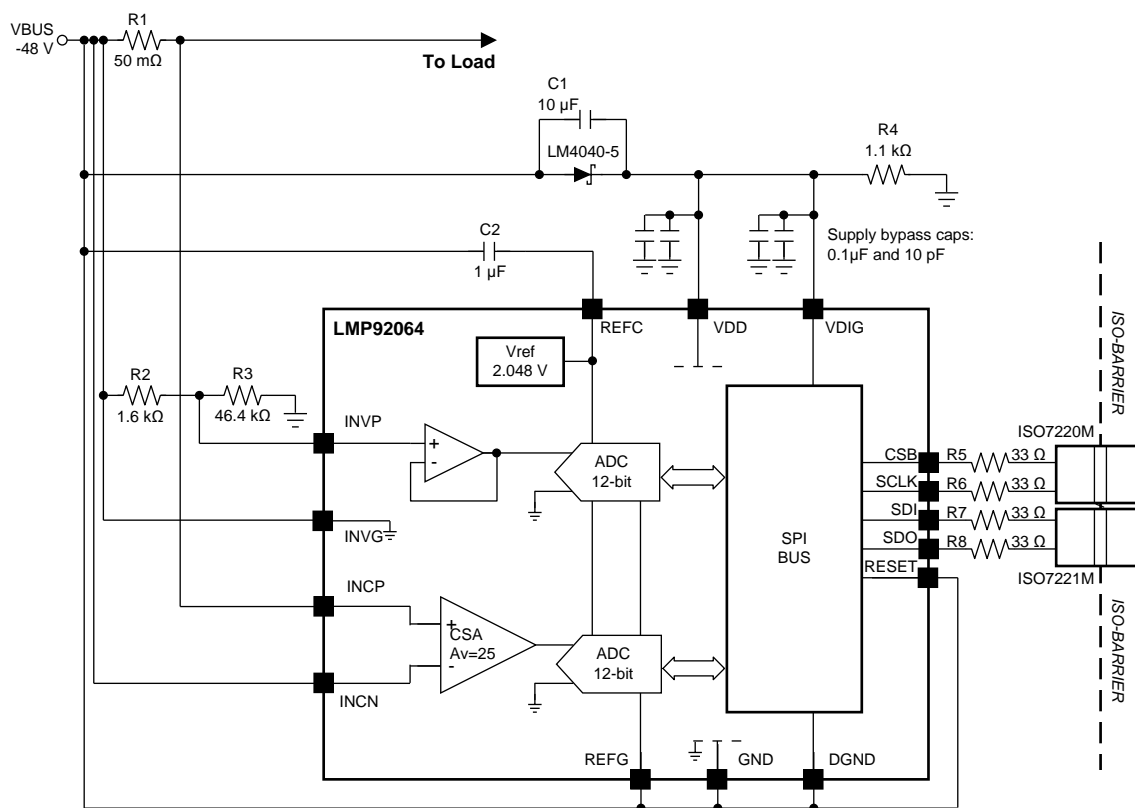

Figure 23. Typical Application Diagram

Typical Application (continued)

8.2.1 Design Requirements

For this design example, use the parameters listed in [Table 19](#) as the application parameters.

Table 19. Design Parameters

DESIGN PARAMETER	EXAMPLE VALUE
Bus Voltage	-48 V
Bus Voltage Variation	±2%
Supply Voltage	5 V
SPI Clock	12 MHz
Maximum Load Current	1 A
Resolution	1 mA

8.2.2 Detailed Design Procedure

8.2.2.1 Digital Isolators

The ISO7220M and ISO7221M isolators are used for this example. Please refer to the ISO722x documentation for device specific information. These devices support data rates of up to 150 Mbps and provide a low propagation delay necessary for bi-directional SPI communication at 12 MHz.

8.2.2.2 Supply Voltage for the LMP92064

A 5-V supply is required for the LMP92064. The LM4040-5 reference is used to generate the required voltage from the load's -48-V supply. The LM4040-N is a precision micropower shunt voltage reference and is available in several fixed breakdown voltage options. The LM4040-5 provides the required 5-V breakdown voltage.

In a conventional shunt regulator application ([Figure 24](#)), the LM4040-5 requires a current limiting resistor connected between the positive supply voltage and the LM4040-5.

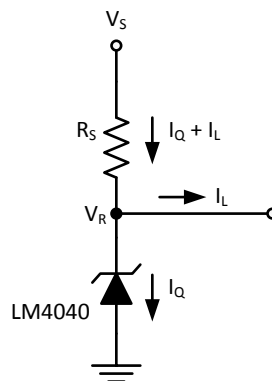

Figure 24. Shunt Regulator

The value of the resistor is determined by the positive supply voltage (V_S), the load current (I_L), the reference operating current (I_Q), and the LM4040-5's reverse breakdown voltage (V_R).

$$R_S = \frac{V_S - V_R}{I_L + I_Q} \quad (1)$$

8.2.2.3 Series Resistor for the Shunt Regulator

The selection of R_S should satisfy two main conditions:

- R_S should be small enough to supply at least the minimum acceptable I_Q to the LM4040-5 even when the supply voltage is at its minimum and the load current is at its maximum value.
- R_S should be large enough so that the current flowing through the LM4040-5 is less than 15 mA when the supply voltage is at its maximum and the load current is at its minimum.

The minimum operating current of the LM4040AIM3-5/NOPB is 80 μ A and its maximum operating current is 15 mA.

The typical supply current of the LMP92064 is 13 mA. The measured average current of the circuit, including the isolators, is 38 mA.

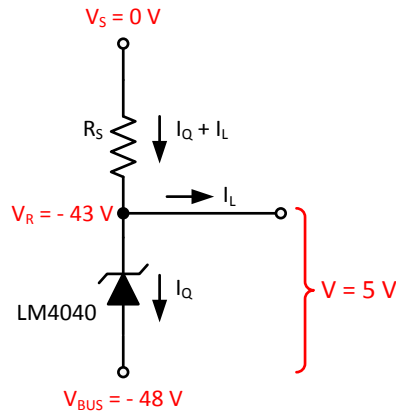

Figure 25. Shunt Regulator Voltages

From Figure 25, $V_S = 0$ V and $V_R = -43$ V. R_S can be calculated as follows:

$$R_S = \frac{0\text{ V} - (-43\text{ V})}{38\text{ mA} + 80\mu\text{A}} = 1129\ \Omega \quad (2)$$

Choosing a smaller resistor, like a 1.1-k Ω resistor, will result in about 39.1 mA to flowing through R_S , providing a margin of 1 mA above the required 38.08 mA.

A variation in the bus voltage (V_{BUS}) of $\pm 2\%$ would result in less than ± 0.87 mA of current variation. Given the additional current margin obtained by the 1.1-k Ω resistor, the shunt regulator would still have more than the required 80 μ A of operating current.

The power rating of the series resistor should be selected according to the expected power to be dissipated. In normal operation, the resistor would dissipate 43 V x 39 mA = 1.677 W.

Excess current not used by the LMP92064 and isolators circuits will be burned by in the LM4040-5, and this current should never exceed 15 mA.

8.2.2.4 Voltage Channel Input Resistor Divider

The input buffer amplifier of the LMP92064's voltage channel can tolerate high source impedances, which enables scaling the bus voltage with the use of an external resistor divider. The accuracy of the voltage measurements depends on the accuracy of the components used for the resistor divider as well as the impedance of the divider.

In this example, the voltage channel can sense the voltage across R2 (see Figure 23). The main voltage should be scaled to a range below 2.048V by the resistive divider. If the resistive divider is always connected to the bus voltage, the series resistance of R2 + R3 should be adjusted (while keeping their ratio constant) to limit the current across the resistors within a permissible range for the application.

For simplicity, R2 is set to 1.6k Ω and R3 is set to 46.4 k Ω . The bus voltage of 48 V results in 1.6 V across R2 and the current flowing through R2 and R3 is 1 mA.

8.2.2.5 Sense Resistor Selection

The accuracy of the current measurement depends heavily on the accuracy of the current sense resistor. Its value depends on the application and it is a compromise between signal accuracy, maximum permissible voltage loss and power dissipation in the current sense resistor. High resistance values provide better accuracy at lower currents by minimizing the effects of offset, while low resistance values of minimize voltage loss in the load supply section, but at the expense of low-end accuracy.

In this example, the maximum sense voltage at the input of the current sense channel of the LMP92064 is 75 mV. Given the maximum load current requirement of 1 A, the sense resistor should be selected to be smaller than 75 mΩ.

The resolution at the input of the current sense channel of the device is 20 μV / code. To observe a change in the output code for a 1 mA change in sense current, the sense resistor should be larger than 20 mΩ.

8.2.3 Application Curves

The data in the following curves was collected using a 50 mΩ sense resistor, which results in a conversion factor of 2.5 codes/mA. The sense current for the first curve was increased in steps of 100 mA up to 1 A. The sense current for the second curve was increased in steps of 1 mA up to 10 mA. The data was acquired asynchronously at a rate of 2000 samples per second, and each data point is the resulting average of 260 samples.

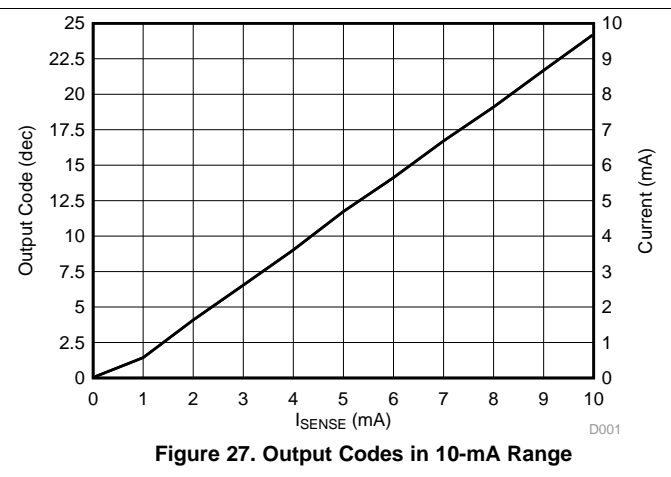
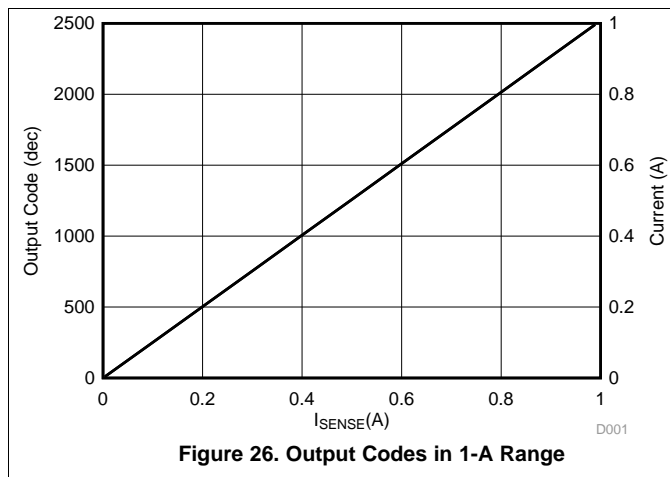

9 Power Supply Recommendations

To decouple the LMP92064 from AC noise on the power supply, it is recommended to use a 0.1- μ F bypass capacitor between the VDD and GND pins. This capacitor should be placed as close as possible to the supply pins. In some cases an additional 10- μ F bypass capacitor may further reduce the supply noise. In addition, the VDIG power pin should also be decoupled to DGND with a 0.1- μ F bypass capacitor. Do not forget that these capacitors must be rated for the full supply voltage (2x the maximum voltage is recommended for the capacitor working voltage rating).

10 Layout

10.1 Layout Guidelines

- Connect the sense resistor pads directly to the INCP and INCN inputs of the LMP92064 using “Kelvin” or “4-wire” connection techniques. See the [Current Input Error Sources and Layout Considerations](#) section for more information.
- Bypass capacitors should be placed in close proximity to the supply pins. It is recommended to use a 0.1- μ F capacitor on each supply pin. Additional bypass capacitors can be used.
- A 1- μ F ceramic bypass capacitor should be placed in close proximity to the REFC pin.
- The SPI signals traces should be routed close together.
- Series resistors should be placed at the SPI sources.

10.1.1 Current Input Error Sources

The traces leading to and from the sense resistor can be significant error sources. With small value sense resistors (<100 m Ω), trace resistance shared with the load can cause significant errors. TI recommends connecting the sense resistor pads directly to the INCP and INCN inputs of the LMP92064 using “Kelvin” or “4-wire” connection techniques. An example is shown in [Figure 28](#).

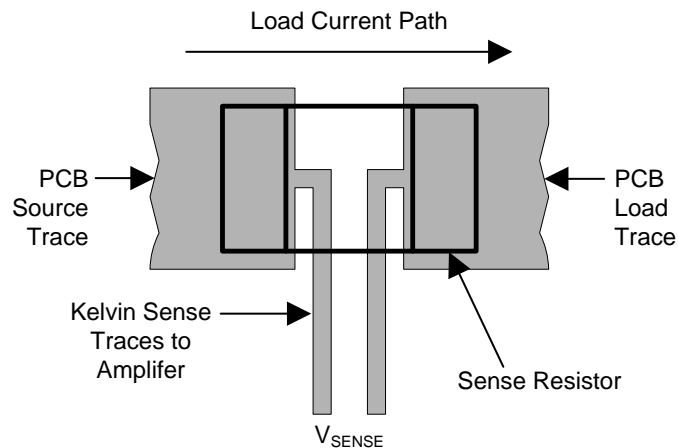

Figure 28. 4-Wire "Kelvin" Sensing Technique

Because the sense traces only carry the amplifier bias current, the connecting input traces can be thinner, signal level traces. The traces should be one continuous piece of copper from the sense resistor pad to the LMP92064 input pin pad, and ideally on the same layer with minimal vias or connectors. This can be important around the sense resistor if it is generating any significant heat. To minimize noise pickup and thermal errors, the input traces should be treated as a signal pair and routed tightly together with a direct path to the input pins. The input traces should be run away from noise sources, such as digital lines, switching supplies or motor drive lines.

10.2 Layout Example

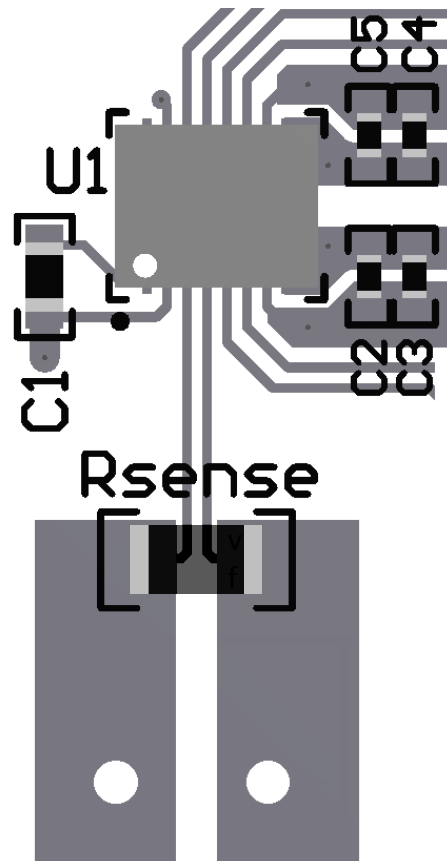

Figure 29. Layout Schematic

11 器件和文档支持

11.1 商标

All trademarks are the property of their respective owners.

11.2 静电放电警告



这些装置包含有限的内置 ESD 保护。存储或装卸时，应将导线一起截短或将装置放置于导电泡棉中，以防止 MOS 门极遭受静电损伤。

11.3 术语表

[SLYZ022](#) — TI 术语表。

这份术语表列出并解释术语、首字母缩略词和定义。

12 机械、封装和可订购信息

以下页中包括机械、封装和可订购信息。 这些信息是针对指定器件可提供的最新数据。 这些数据会在无通知且不对本文档进行修订的情况下发生改变。 欲获得该数据表的浏览器版本，请查阅左侧的导航栏。

重要声明

德州仪器(TI)及其下属子公司有权根据 JESD46 最新标准,对所提供的产品和服务进行更正、修改、增强、改进或其它更改,并有权根据 JESD48 最新标准中止提供任何产品和服务。客户在下订单前应获取最新的相关信息,并验证这些信息是否完整且是最新的。所有产品的销售都遵循在订单确认时所提供的TI 销售条款与条件。

TI 保证其所销售的组件的性能符合产品销售时 TI 半导体产品销售条件与条款的适用规范。仅在 TI 保证的范围内,且 TI 认为有必要时才会使用测试或其它质量控制技术。除非适用法律做出了硬性规定,否则没有必要对每种组件的所有参数进行测试。

TI 对应用帮助或客户产品设计不承担任何义务。客户应对其使用 TI 组件的产品和应用自行负责。为尽量减小与客户产品和应用相关的风险,客户应提供充分的设计与操作安全措施。

TI 不对任何 TI 专利权、版权、屏蔽作品权或其它与使用了 TI 组件或服务的组合设备、机器或流程相关的 TI 知识产权中授予的直接或隐含权限作出任何保证或解释。TI 所发布的与第三方产品或服务有关的信息,不能构成从 TI 获得使用这些产品或服务的许可、授权、或认可。使用此类信息可能需要获得第三方的专利权或其它知识产权方面的许可,或是 TI 的专利权或其它知识产权方面的许可。

对于 TI 的产品手册或数据表中 TI 信息的重要部分,仅在没有对内容进行任何篡改且带有相关授权、条件、限制和声明的情况下才允许进行复制。TI 对此类篡改过的文件不承担任何责任或义务。复制第三方的信息可能需要服从额外的限制条件。

在转售 TI 组件或服务时,如果对该组件或服务参数的陈述与 TI 标明的参数相比存在差异或虚假成分,则会失去相关 TI 组件或服务的所有明示或暗示授权,且这是不正当的、欺诈性商业行为。TI 对任何此类虚假陈述均不承担任何责任或义务。

客户认可并同意,尽管任何应用相关信息或支持仍可能由 TI 提供,但他们将独立负责满足与其产品及其在应用中使用的 TI 产品相关的所有法律、法规和安全相关要求。客户声明并同意,他们具备制定与实施安全措施所需的全部专业技术和知识,可预见故障的危险后果、监测故障及其后果、降低有可能造成人身伤害的故障的发生机率并采取适当的补救措施。客户将全额赔偿因在此类安全关键应用中使用任何 TI 组件而对 TI 及其代理造成的任何损失。

在某些场合中,为了推进安全相关应用有可能对 TI 组件进行特别的促销。TI 的目标是利用此类组件帮助客户设计和创立其特有的可满足适用的功能安全性标准和要求的终端产品解决方案。尽管如此,此类组件仍然服从这些条款。

TI 组件未获得用于 FDA Class III (或类似的生命攸关医疗设备)的授权许可,除非各方授权官员已经达成了专门管控此类使用的特别协议。

只有那些 TI 特别注明属于军用等级或“增强型塑料”的 TI 组件才是设计或专门用于军事/航空应用或环境的。购买者认可并同意,对并非指定向军事或航空航天用途的 TI 组件进行军事或航空航天方面的应用,其风险由客户单独承担,并且由客户独立负责满足与此类使用相关的所有法律和法规要求。

TI 已明确指定符合 ISO/TS16949 要求的产品,这些产品主要用于汽车。在任何情况下,因使用非指定产品而无法达到 ISO/TS16949 要求, TI 不承担任何责任。

	产品		应用
数字音频	www.ti.com.cn/audio	通信与电信	www.ti.com.cn/telecom
放大器和线性器件	www.ti.com.cn/amplifiers	计算机及周边	www.ti.com.cn/computer
数据转换器	www.ti.com.cn/dataconverters	消费电子	www.ti.com.cn/consumer-apps
DLP® 产品	www.dlp.com	能源	www.ti.com.cn/energy
DSP - 数字信号处理器	www.ti.com.cn/dsp	工业应用	www.ti.com.cn/industrial
时钟和计时器	www.ti.com.cn/clockandtimers	医疗电子	www.ti.com.cn/medical
接口	www.ti.com.cn/interface	安防应用	www.ti.com.cn/security
逻辑	www.ti.com.cn/logic	汽车电子	www.ti.com.cn/automotive
电源管理	www.ti.com.cn/power	视频和影像	www.ti.com.cn/video
微控制器 (MCU)	www.ti.com.cn/microcontrollers		
RFID 系统	www.ti.com.cn/rfidsys		
OMAP应用处理器	www.ti.com/omap		
无线连通性	www.ti.com.cn/wirelessconnectivity	德州仪器在线技术支持社区	www.deyisupport.com

邮寄地址: 上海市浦东新区世纪大道1568号, 中建大厦32楼邮政编码: 200122
Copyright © 2015, 德州仪器半导体技术(上海)有限公司

PACKAGING INFORMATION

Orderable Device	Status (1)	Package Type	Package Drawing	Pins	Package Qty	Eco Plan (2)	Lead/Ball Finish (6)	MSL Peak Temp (3)	Op Temp (°C)	Device Marking (4/5)	Samples
LMP92064SD/NOPB	ACTIVE	WSON	NHR	16	1000	Green (RoHS & no Sb/Br)	CU SN	Level-3-260C-168 HR	-40 to 105	L92064	Samples
LMP92064SDE/NOPB	ACTIVE	WSON	NHR	16	250	Green (RoHS & no Sb/Br)	CU SN	Level-3-260C-168 HR	-40 to 105	L92064	Samples
LMP92064SDX/NOPB	ACTIVE	WSON	NHR	16	4500	Green (RoHS & no Sb/Br)	CU SN	Level-3-260C-168 HR	-40 to 105	L92064	Samples

(1) The marketing status values are defined as follows:

ACTIVE: Product device recommended for new designs.

LIFEBUY: TI has announced that the device will be discontinued, and a lifetime-buy period is in effect.

NRND: Not recommended for new designs. Device is in production to support existing customers, but TI does not recommend using this part in a new design.

PREVIEW: Device has been announced but is not in production. Samples may or may not be available.

OBsolete: TI has discontinued the production of the device.

(2) Eco Plan - The planned eco-friendly classification: Pb-Free (RoHS), Pb-Free (RoHS Exempt), or Green (RoHS & no Sb/Br) - please check <http://www.ti.com/productcontent> for the latest availability information and additional product content details.

TBD: The Pb-Free/Green conversion plan has not been defined.

Pb-Free (RoHS): TI's terms "Lead-Free" or "Pb-Free" mean semiconductor products that are compatible with the current RoHS requirements for all 6 substances, including the requirement that lead not exceed 0.1% by weight in homogeneous materials. Where designed to be soldered at high temperatures, TI Pb-Free products are suitable for use in specified lead-free processes.

Pb-Free (RoHS Exempt): This component has a RoHS exemption for either 1) lead-based flip-chip solder bumps used between the die and package, or 2) lead-based die adhesive used between the die and leadframe. The component is otherwise considered Pb-Free (RoHS compatible) as defined above.

Green (RoHS & no Sb/Br): TI defines "Green" to mean Pb-Free (RoHS compatible), and free of Bromine (Br) and Antimony (Sb) based flame retardants (Br or Sb do not exceed 0.1% by weight in homogeneous material)

(3) MSL, Peak Temp. - The Moisture Sensitivity Level rating according to the JEDEC industry standard classifications, and peak solder temperature.

(4) There may be additional marking, which relates to the logo, the lot trace code information, or the environmental category on the device.

(5) Multiple Device Markings will be inside parentheses. Only one Device Marking contained in parentheses and separated by a "~" will appear on a device. If a line is indented then it is a continuation of the previous line and the two combined represent the entire Device Marking for that device.

(6) Lead/Ball Finish - Orderable Devices may have multiple material finish options. Finish options are separated by a vertical ruled line. Lead/Ball Finish values may wrap to two lines if the finish value exceeds the maximum column width.

Important Information and Disclaimer: The information provided on this page represents TI's knowledge and belief as of the date that it is provided. TI bases its knowledge and belief on information provided by third parties, and makes no representation or warranty as to the accuracy of such information. Efforts are underway to better integrate information from third parties. TI has taken and

continues to take reasonable steps to provide representative and accurate information but may not have conducted destructive testing or chemical analysis on incoming materials and chemicals. TI and TI suppliers consider certain information to be proprietary, and thus CAS numbers and other limited information may not be available for release.

In no event shall TI's liability arising out of such information exceed the total purchase price of the TI part(s) at issue in this document sold by TI to Customer on an annual basis.

TAPE AND REEL INFORMATION

QUADRANT ASSIGNMENTS FOR PIN 1 ORIENTATION IN TAPE

*All dimensions are nominal

Device	Package Type	Package Drawing	Pins	SPQ	Reel Diameter (mm)	Reel Width W1 (mm)	A0 (mm)	B0 (mm)	K0 (mm)	P1 (mm)	W (mm)	Pin1 Quadrant
LMP92064SD/NOPB	WSON	NHR	16	1000	178.0	12.4	4.3	5.3	1.3	8.0	12.0	Q1
LMP92064SDE/NOPB	WSON	NHR	16	250	178.0	12.4	4.3	5.3	1.3	8.0	12.0	Q1
LMP92064SDX/NOPB	WSON	NHR	16	4500	330.0	12.4	4.3	5.3	1.3	8.0	12.0	Q1

TAPE AND REEL BOX DIMENSIONS

*All dimensions are nominal

Device	Package Type	Package Drawing	Pins	SPQ	Length (mm)	Width (mm)	Height (mm)
LMP92064SD/NOPB	WSON	NHR	16	1000	210.0	185.0	35.0
LMP92064SDE/NOPB	WSON	NHR	16	250	210.0	185.0	35.0
LMP92064SDX/NOPB	WSON	NHR	16	4500	367.0	367.0	35.0

NHR0016B

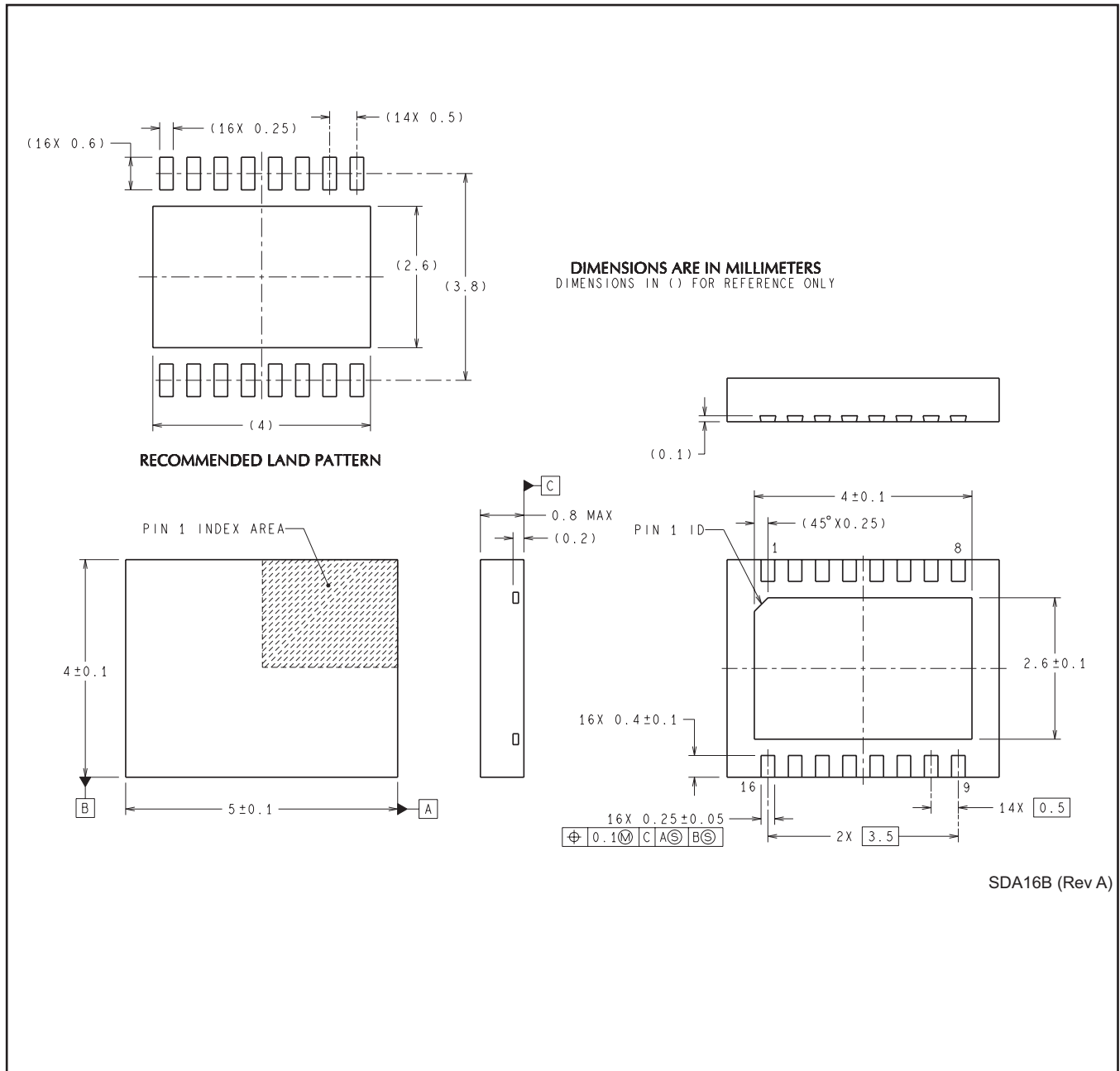

重要声明

德州仪器(TI) 及其下属子公司有权根据 JESD46 最新标准, 对所提供的产品和服务进行更正、修改、增强、改进或其它更改, 并有权根据 JESD48 最新标准中止提供任何产品和服务。客户在下订单前应获取最新的相关信息, 并验证这些信息是否完整且是最新的。所有产品的销售都遵循在订单确认时所提供的TI 销售条款与条件。

TI 保证其所销售的组件的性能符合产品销售时 TI 半导体产品销售条件与条款的适用规范。仅在 TI 保证的范围内, 且 TI 认为有必要时才会使用测试或其它质量控制技术。除非适用法律做出了硬性规定, 否则没有必要对每种组件的所有参数进行测试。

TI 对应用帮助或客户产品设计不承担任何义务。客户应对其使用 TI 组件的产品和应用自行负责。为尽量减小与客户产品和应用相关的风险, 客户应提供充分的设计与操作安全措施。

TI 不对任何 TI 专利权、版权、屏蔽作品权或其它与使用了 TI 组件或服务的组合设备、机器或流程相关的 TI 知识产权中授予的直接或间接版权限作出任何保证或解释。TI 所发布的与第三方产品或服务有关的信息, 不能构成从 TI 获得使用这些产品或服务的许可、授权、或认可。使用此类信息可能需要获得第三方的专利权或其它知识产权方面的许可, 或是 TI 的专利权或其它知识产权方面的许可。

对于 TI 的产品手册或数据表中 TI 信息的重要部分, 仅在没有对内容进行任何篡改且带有相关授权、条件、限制和声明的情况下才允许进行复制。TI 对此类篡改过的文件不承担任何责任或义务。复制第三方的信息可能需要服从额外的限制条件。

在转售 TI 组件或服务时, 如果对该组件或服务参数的陈述与 TI 标明的参数相比存在差异或虚假成分, 则会失去相关 TI 组件或服务的所有明示或暗示授权, 且这是不正当的、欺诈性商业行为。TI 对任何此类虚假陈述均不承担任何责任或义务。

客户认可并同意, 尽管任何应用相关信息或支持仍可能由 TI 提供, 但他们将独自负责满足与其产品及其应用中使用 TI 产品相关的所有法律、法规和安全相关要求。客户声明并同意, 他们具备制定与实施安全措施所需的全部专业技术和知识, 可预见故障的危险后果、监测故障及其后果、降低有可能造成人身伤害的故障的发生机率并采取适当的补救措施。客户将全额赔偿因在此类安全关键应用中使用任何 TI 组件而对 TI 及其代理造成的任何损失。

在某些场合中, 为了推进安全相关应用有可能对 TI 组件进行特别的促销。TI 的目标是利用此类组件帮助客户设计和创立其特有的可满足适用的功能安全性标准和要求的终端产品解决方案。尽管如此, 此类组件仍然服从这些条款。

TI 组件未获得用于 FDA Class III (或类似的生命攸关医疗设备) 的授权许可, 除非各方授权官员已经达成了专门管控此类使用的特别协议。

只有那些 TI 特别注明属于军用等级或“增强型塑料”的 TI 组件才是设计或专门用于军事/航空应用或环境的。购买者认可并同意, 对并非指定面向军事或航空航天用途的 TI 组件进行军事或航空航天方面的应用, 其风险由客户单独承担, 并且由客户独自负责满足与此类使用相关的所有法律和法规要求。

TI 已明确指定符合 ISO/TS16949 要求的产品, 这些产品主要用于汽车。在任何情况下, 因使用非指定产品而无法达到 ISO/TS16949 要求, TI 不承担任何责任。

	产品		应用
数字音频	www.ti.com.cn/audio	通信与电信	www.ti.com.cn/telecom
放大器和线性器件	www.ti.com.cn/amplifiers	计算机及周边	www.ti.com.cn/computer
数据转换器	www.ti.com.cn/dataconverters	消费电子	www.ti.com.cn/consumer-apps
DLP® 产品	www.dlp.com	能源	www.ti.com.cn/energy
DSP - 数字信号处理器	www.ti.com.cn/dsp	工业应用	www.ti.com.cn/industrial
时钟和计时器	www.ti.com.cn/clockandtimers	医疗电子	www.ti.com.cn/medical
接口	www.ti.com.cn/interface	安防应用	www.ti.com.cn/security
逻辑	www.ti.com.cn/logic	汽车电子	www.ti.com.cn/automotive
电源管理	www.ti.com.cn/power	视频和影像	www.ti.com.cn/video
微控制器 (MCU)	www.ti.com.cn/microcontrollers		
RFID 系统	www.ti.com.cn/rfidsys		
OMAP应用处理器	www.ti.com.cn/omap		
无线连通性	www.ti.com.cn/wirelessconnectivity	德州仪器在线技术支持社区	www.deyisupport.com

Mailing Address: Texas Instruments, Post Office Box 655303, Dallas, Texas 75265
Copyright © 2016, Texas Instruments Incorporated