



DATASHEET -Preliminary-

Surface Acoustic Wave Filter

- **Application : TC-SAW LTE Band 8**
- **Model : SFX897EYT02**
- **Center Frequency : 897.5 / 942.5 [MHz]**



WISOL CO., LTD.

373-7, GAJANG-DONG, OSAN-SI
GYUNGGI-DO, KOREA, 447-210

<http://www.wisol.co.kr>

E-mail: sales@wisol.co.kr

1. OUTLINE DRAWING & RECOMMENDED PCB

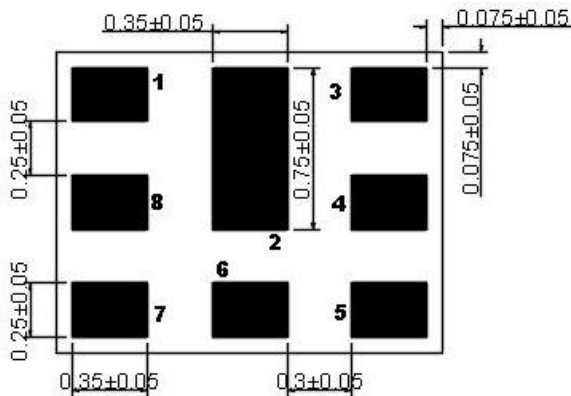
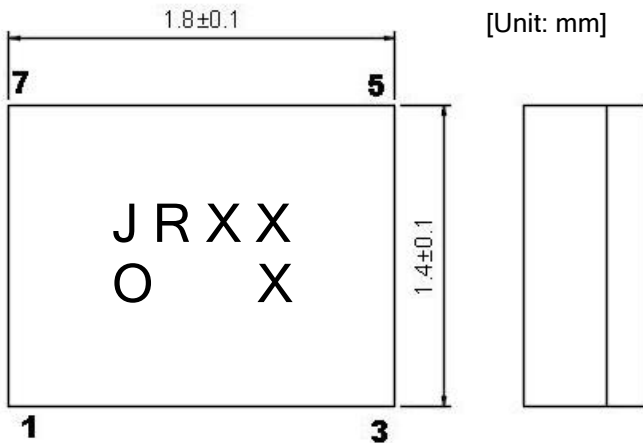

No.	Function
1	Rx Output
3	Tx Input
6	Antenna
2, 4, 5, 7, 8	GND

2. TEST FIXTURE

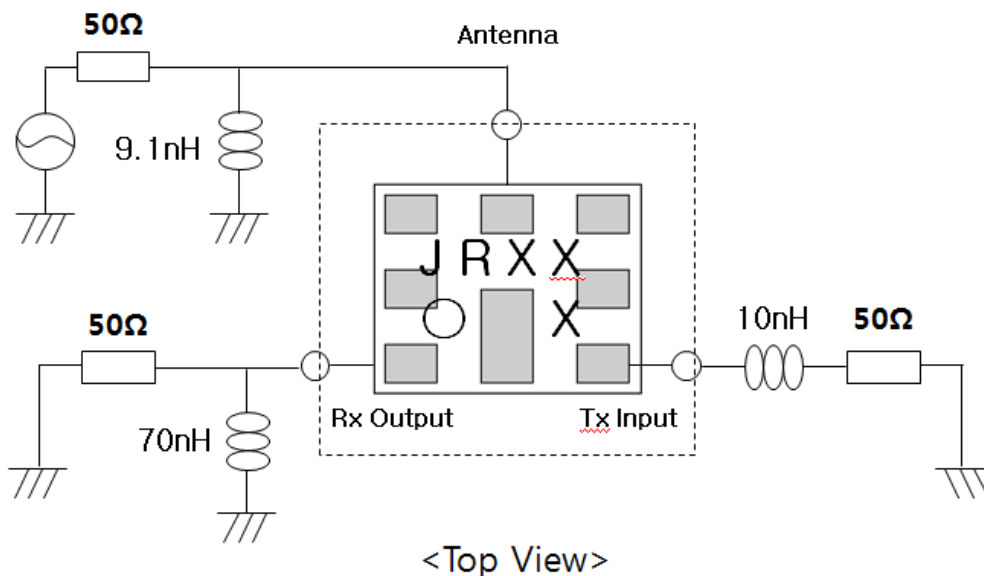

3. PERFORMANCE

3-1. MAXIMUM RATINGS

CHARACTERISTICS	RATINGS	UNITS
DC Permissive Voltage	5	V
Maximum Input Power	0.8	W
Operating Temperature Range	- 20 ~ + 85	°C
Storage Temperature Range	- 40 ~ + 85	°C

3-2. ELECTRICAL CHARACTERISTICS

3-2-1. TABLE

Ta = -20 ~ +85°C

*1. PCB loss is de-embedded.

Item	CONDITION [MHz]	UNIT	RATING			Note
			Min.	Typ.(25°C)	Max.	
TX → ANTENNA						
Insertion Loss(*1)	880 ~ 915	dB		1.7	3.6	
Inband Ripple	880 ~ 915	dB		1	3	
VSWR	880 ~ 915	-		1.8	2.5	
Absolute Attenuation	10 ~ 830	dB	25	30		
	925 ~ 960	dB	40	46		
	970~1005	dB	17	22		
	1559.1 ~1605.9	dB	35	43		
	1760~1840	dB	40	49		
	2110~2170	dB	40	45		
	2400~2500	dB	40	44		
	2640~2745	dB	39	44		
	4400~4575	dB	31	36		
Termination Impedance : Tx / ANT			50Ω(+ 10[nH]) / 50Ω(// 9.1[nH])			
ANTENNA → RX						
Insertion Loss(*1)	925 ~ 960	dB		2.1	3.8	
Inband Ripple	925 ~ 960	dB		1.1	2.5	
VSWR	925 ~ 960	-		1.7	2.5	
Absolute Attenuation	10~880	dB	50	56		
	880 ~ 915	dB	45	58		
	980~1785	dB	10	16		

	1805~1920	dB	50	63		
	1980~3000	dB	50	56		
	2400~2500	dB	50	56		
	2685~2790	dB	40	57		
	3000~6000	dB	40	47		
Termination Impedance : ANT / Rx			50Ω(// 9.1[nH]) / 50Ω(// 70[nH])			
TX → RX						
Isolation between Rx and Tx	882.5 ~ 912.5	dBINT	55	59		Any 4.5MHz
	927.5 ~ 957.5	dBINT	54	60		Any 4.5MHz

3-2-2. GRAPH

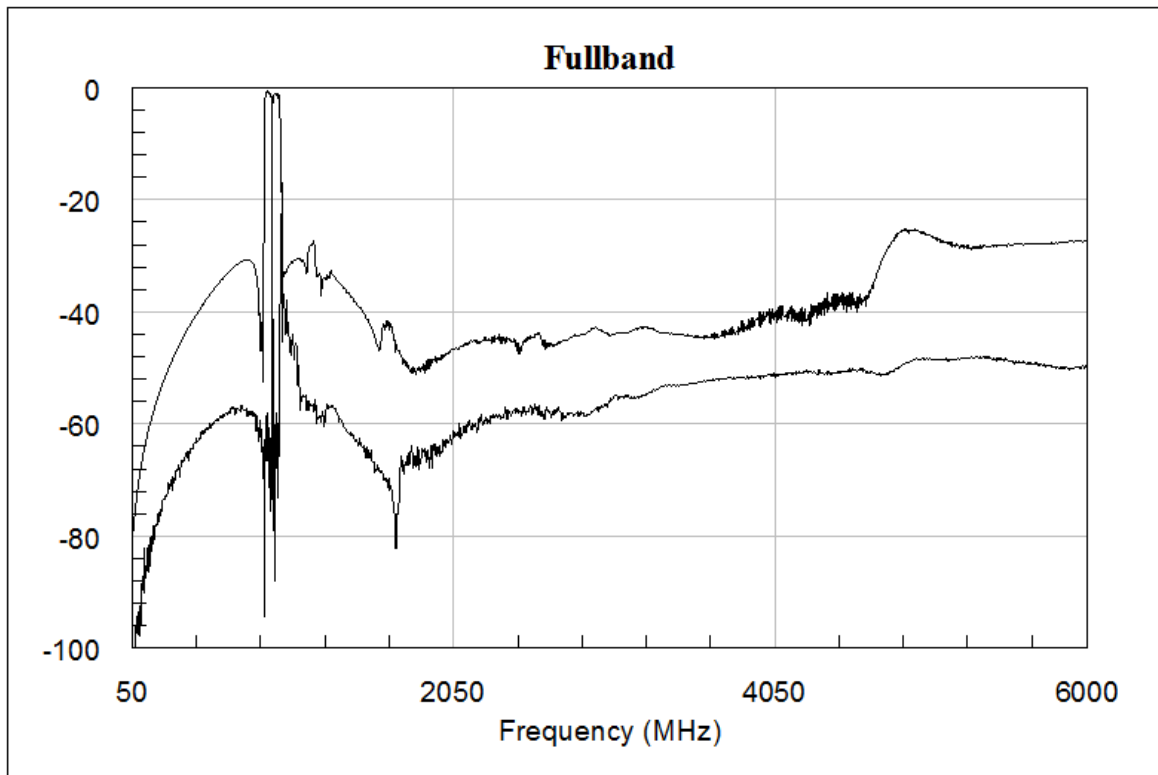
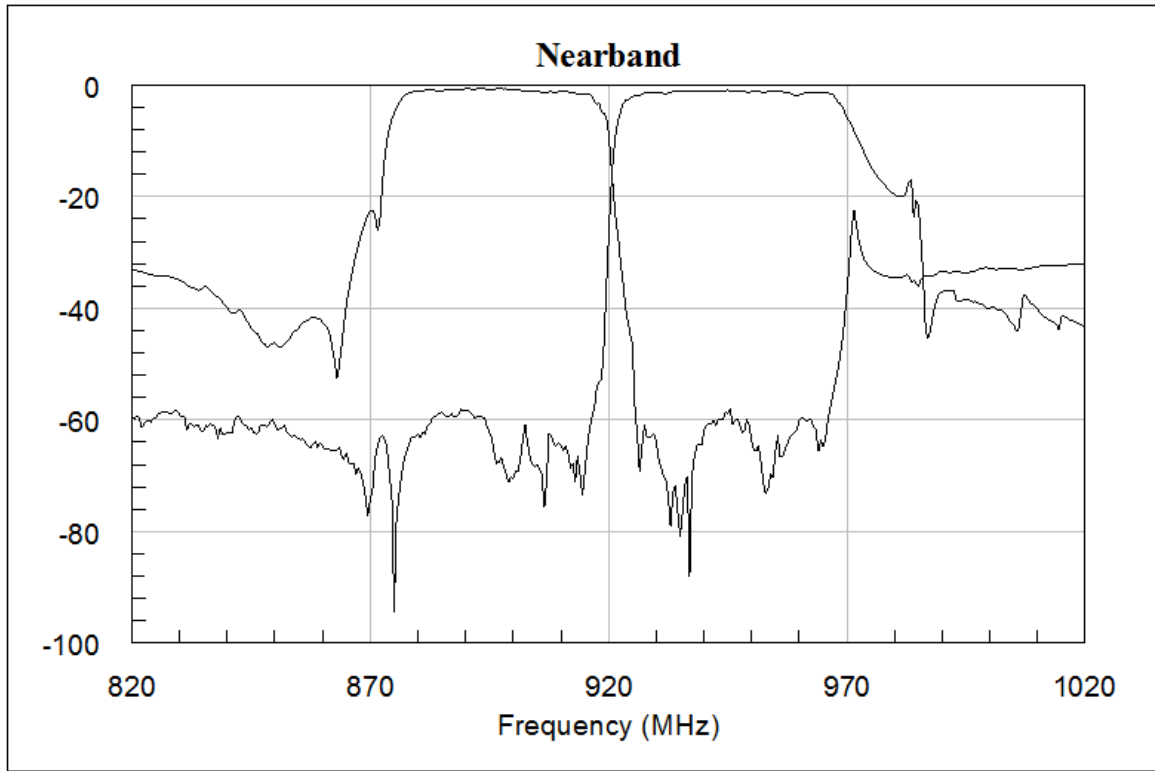

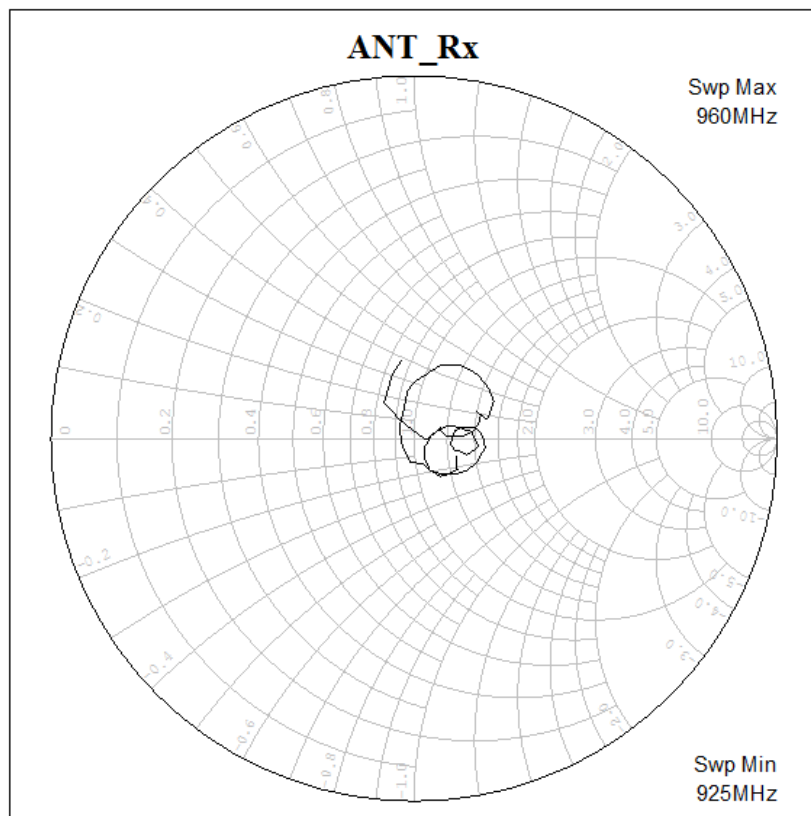
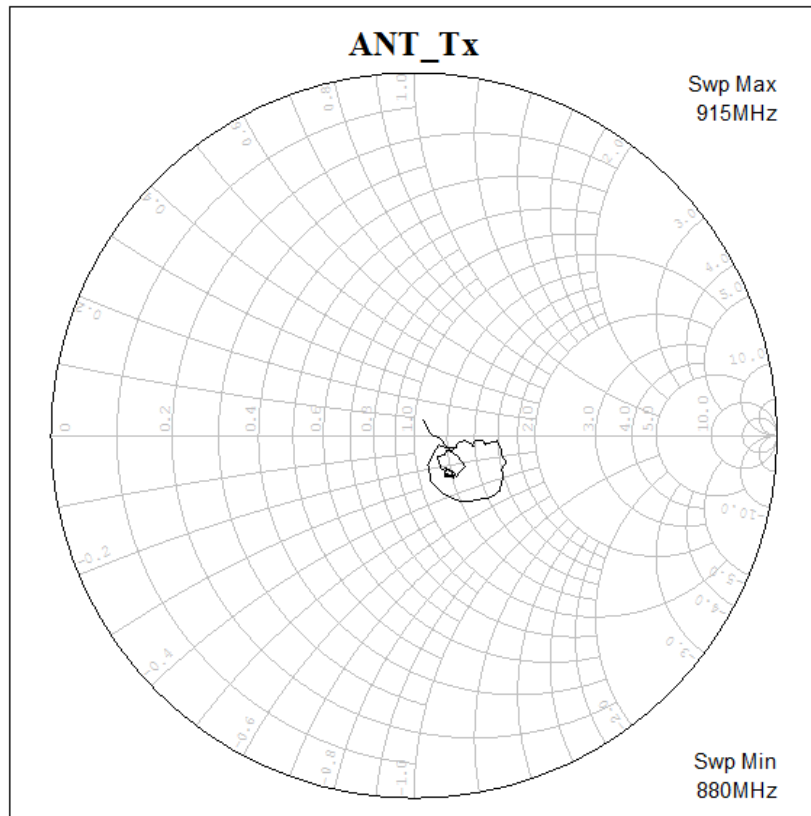

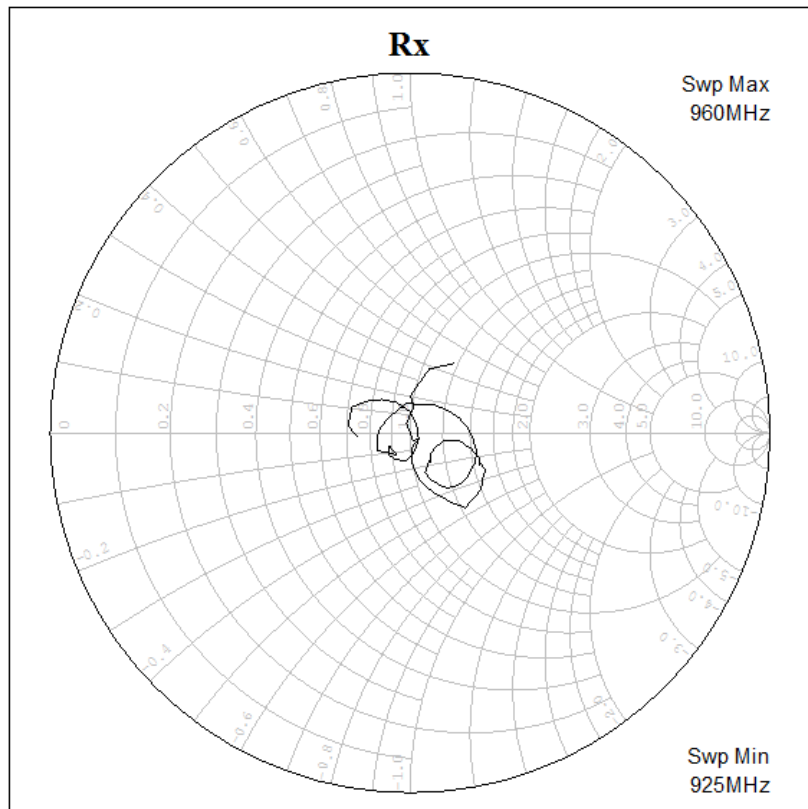
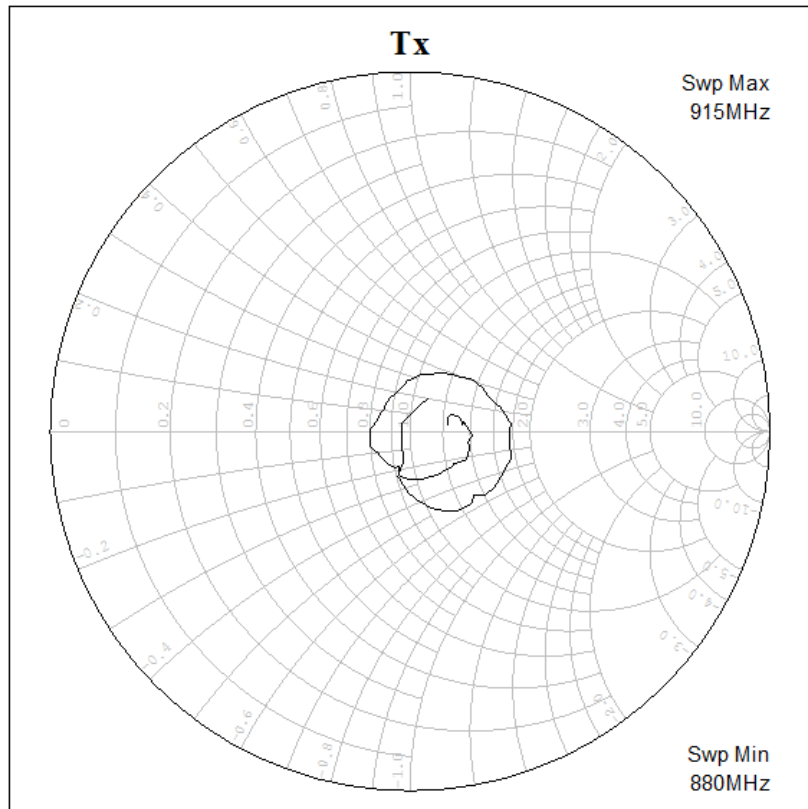

4. PACKING

4-1. DIMENSIONS

- Carrier Tape [Unit: mm]

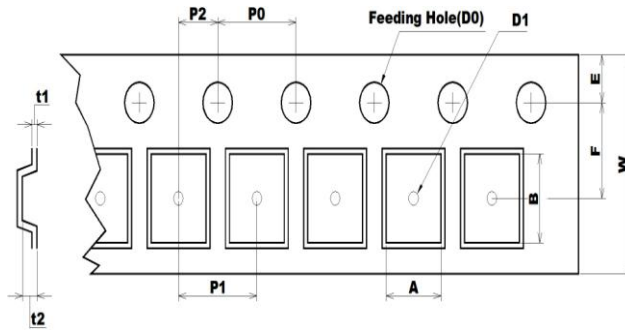

A	B	D0	D1
1.60 +0.05 -0.05	2.00 +0.05 -0.05	Ø1.55 +0.05 -0.05	Ø1.00 MIN
E	F	P0	P1
1.75 +0.10 -0.10	3.50 +0.05 -0.05	4.00 +0.10 -0.10	4.00 +0.10 -0.10
P2	t1	t2	W
2.00 +0.05 -0.05	0.25 +0.05 -0.05	0.80 +0.05 -0.05	8 +0.10 -0.10

- Reel [Unit: mm]

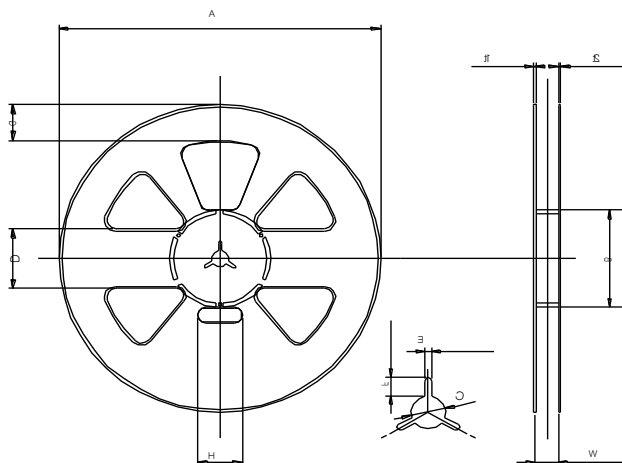

A	B	C	D
Ø258.0 +1.0 -0.5	Ø81.0 +1.0 -1.0	Ø13.0 +0.5 -0.5	50.0 +0.8 -0.8
E	F	G	H
2.2 +0.3 -0.3	7.0 +0.5 -0.5	30.0 +0.8 -0.8	35.0 +1.0 -1.0
t1	t2	W	
1.8 +0.5 -0.5	1.5 +0.5 -0.5	9.0 +1.0 -0.5	

- The product shall be packed properly not to be damaged during transportation and storage.

4-2. REELING QUANTITY

10 inch reel: 8,000 pcs/reel

4-3. TAPING STRUCTURE

The tape shall be wound around the reel in direction shown below.

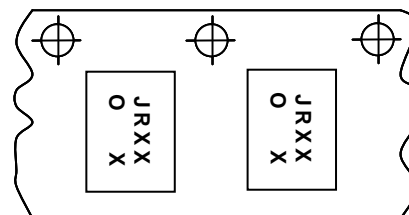
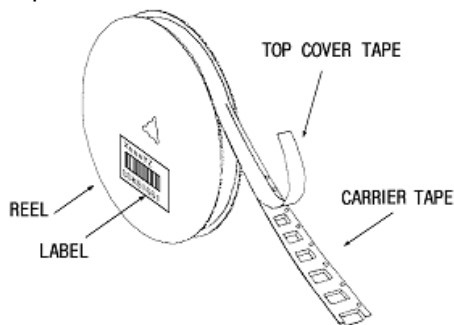

Tape Running direction

