



DEQING HUAYING ELECTRONICS CO.,LTD.

APPROVAL SHEET

SAW BANDPASS FILTER PART NO.: NDFH016-0806SA

Product Type:		Customer:	
SAW Filter			
Part NO.:		Customer Part NO.:	
NDFH016-0806SA			
Ver. Ctrl.:		Issued Date:	
SFH016-0806SA -161226-v1.0			

PREPARED BY	CHECKED BY	APPROVED BY

Part No.	:	NDFH016-0806SA
Pages	:	8
Data	:	2016-12-26
Revision	:	SFH016-806SA -161226-v1.0

Add (Deqing): 188 Zhiyuan North Rd.Wukang Town Deqing County Zhejiang Province 313200,P.R.China
Phone : +86-572-8281127
Fax : +86-572-8281298
E-mail : sales@dghuaying.com
Website : <http://www.dghuaying.com>

Features

SAW filter for LTE BAND 20 (Rx).

- 1 High stability and reliability with good performance and no adjustment.
- 2 Single ended to Single ended.
- 3 Narrow and sharp pass band characteristics. RoHS compatible.
- 4 Low insertion loss and deep stop band attenuation for interference.
- 5 Useable Pass band 30MHz.
- 6 Package size 1.1mm*0.9mm.

Package Dimensions

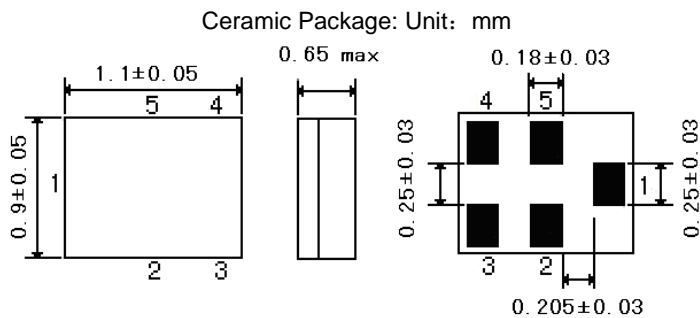

Pin Configuration

1	Unbalance port
4	Unbalance port
2,3,5	Ground

Marking

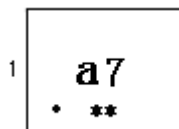

Top View, Laser Marking

"a7" Part number

"." Dot marking, indicates input 1

"1" Terminal1

The first "*" : Month Code (The code shown below varies in a 4-year-cycle)

Month	1	2	3	4	5	6	7	8	9	10	11	12
2016/2020	n	p	q	r	s	t	u	v	w	x	y	z
2017/2021	A	B	C	D	E	F	G	H	J	K	L	M
2018/2022	N	P	Q	R	S	T	U	V	W	X	Y	Z
2019/2023	a	b	c	d	e	f	g	h	i	j	k	m

The second "*" : Date Code

data	1s	2nd	3rd	4th	5th	6th	7th	8th	9th	10th	
code	A	B	C	D	E	F	G	H	J	K	
data	11th	12th	13th	14th	15th	16th	17th	18th	19th	20th	
code	L	M	N	P	Q	R	S	T	U	V	
data	21st	22nd	23rd	24th	25th	26th	27th	28th	29th	30th	31st
code	W	X	Y	Z	a	b	d	e	f	g	h

Maximum Ratings

Rating		Value	Unit
DC Voltage (between any Terminals)	V_{DC}	10	V
RF Power (in BW)	P	15 dBm /2000hr@55°C	
Operating Temperature Range	T_A	-30 ~ +85	°C
Storage Temperature Range	T_{stg}	-40 ~ +85	°C
ESD Voltage (HB)	V_{ESD}	>150	V
Moisture Sensitivity Levels	MSL	2A	

Electrical Characteristics:

Item		Minimum	Typical	Maximum	Unit
Insertion Loss@791 821MHz	IL		2.1	3.0	dB
Passband Ripple@791 821MHz	Pr		0.8	1.8	dB
VSWR @791 821MHz	Vswr		2.0	2.3	
Absolute Attenuation	α				
0 760 MHz		40	50		dB
760 770 MHz		40	45		dB
770 780 MHz		30	45		dB
832 862 MHz		29	36		dB
862.... 880 MHz		47	54		dB
880 1710 MHz		35	42		dB
1710 1785 MHz		35	41		dB
1785 2500 MHz		30	35		dB
2500 3000 MHz		30	33		dB
3000 6000 MHz		23	27		dB
Input / Output Impedance (Nominal)		50			Ω

 **RoHS Compliant**

 **Electrostatic Sensitive Device**

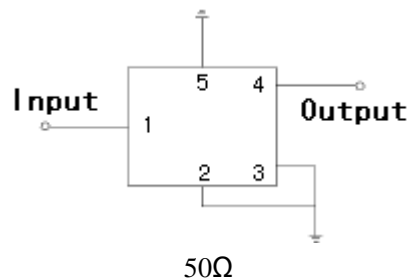
Test Circuit

Typical Frequency Response
S21

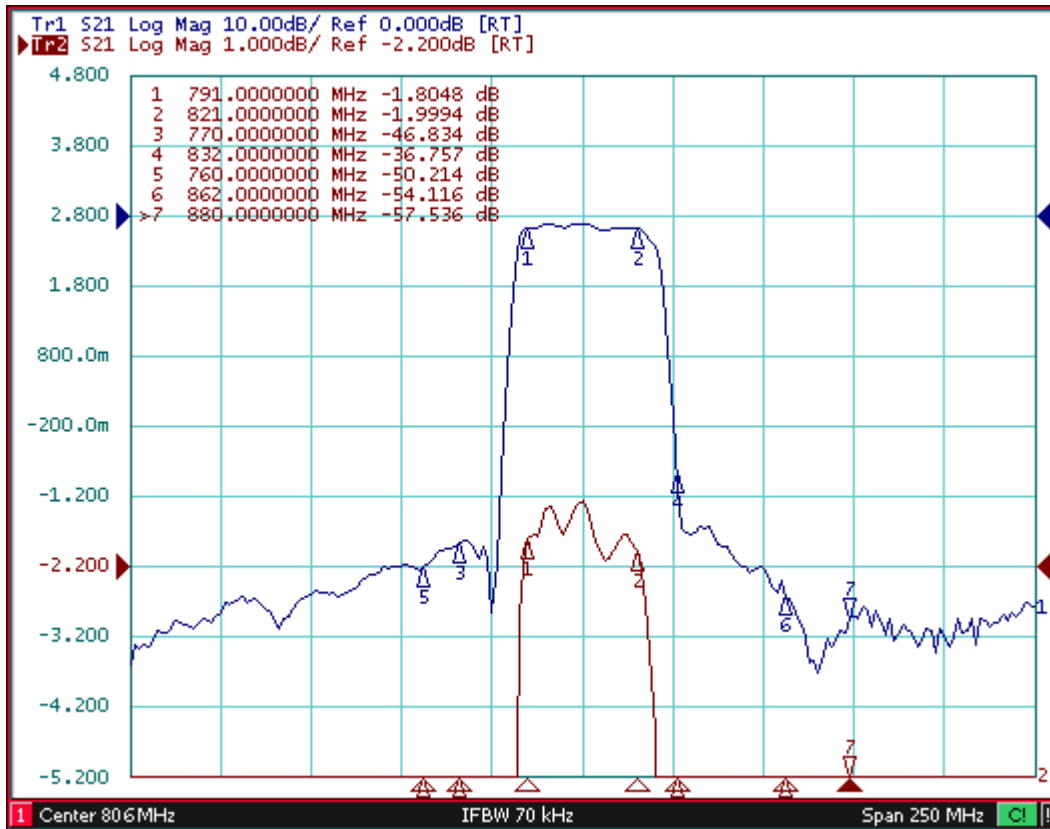

S11 S22

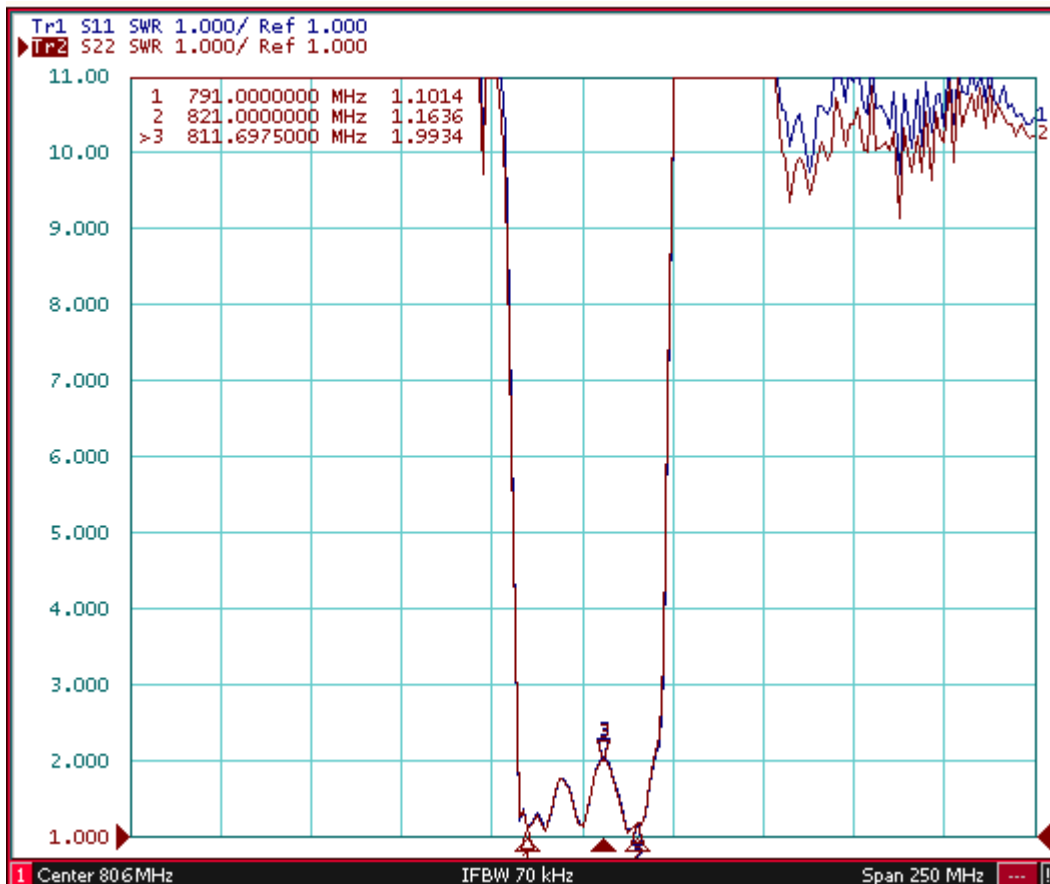

Far side

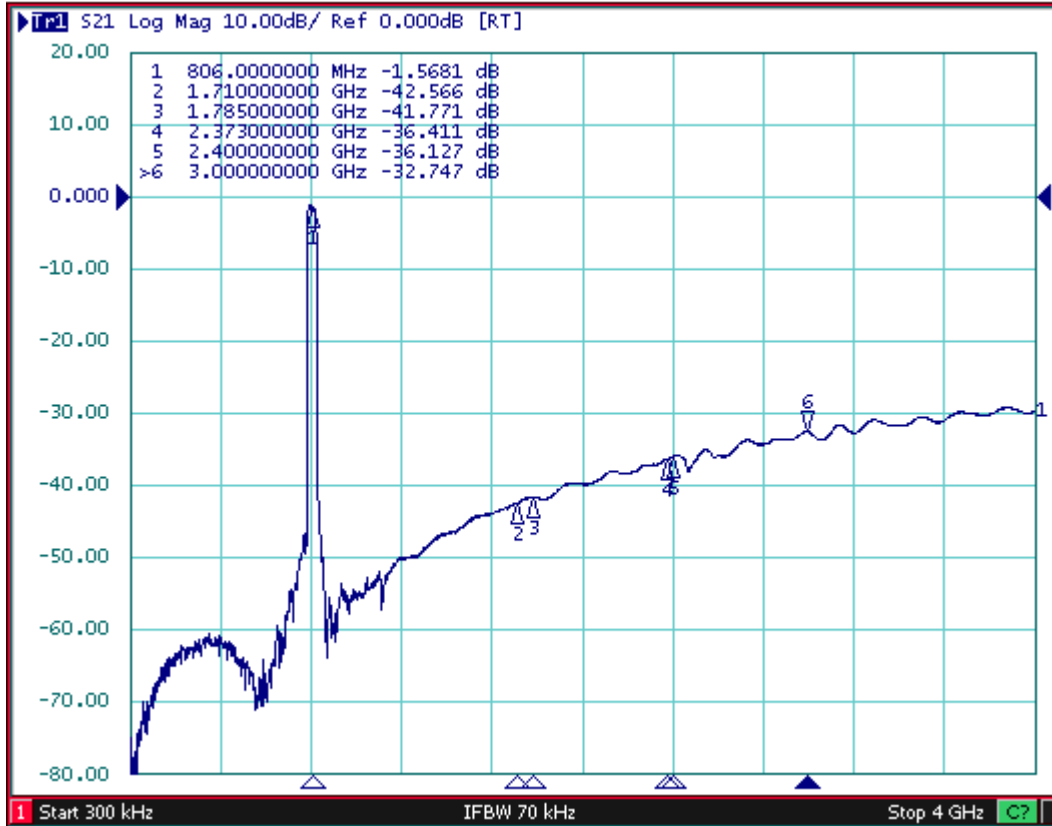

Stability Characteristics

Item No.	Test Item	STD Reference	Test Conditions	per lot
	Preconditioning	JESD22-A113	1) Temperature Cycling, 5 cycles -40°C to 85°C 2) Bake, 24 hrs @125±5°C; 3) Reflow, 3 reflow cycles 4) Drying, Room ambient temperature	177
1	Temperature Cycling	JESD22-A104	-40 °C / +85 °C ,40min dwell,<1 min transfer time,500cycles	23
2	High Temperature Storage	JESD22-A103	85°C,240hr	23
3	Low Temperature Storage	JESD22-A119	-40°C, 240hr	23
4	Temperature Humidity bias	JESD22-A106B	85°C 85%RH 240hr	23
5	Unbiased Temperature/Humidity	JESD22-A102C	+121°C 100%RH 96hr	23
6	Human Body Mode ESD	JESD22-A114F	Ta=25°C, ≥150V	5
7	Drop Test	IEC 68-2-32	100cm , 3times Steel floor JIG(110g~150g)	6
8	Solderability	JESD22-B102	Characterization per JESD22-B102	5
9	Vibration, Variable Frequency	JESD22-B103	20 Hz to 2 kHz (log variation) in > 4 minutes, 4X in each orientation, 20g peak acceleration	23
10	Mechanical Shock	JESD22-B104	Y1 plane only, 5 pulses, 0.5 ms duration, 1500 g peak acceleration	23

Requirements: The SAW filer shall remain within the electrical specifications after tests.

Packing Information

Carrier Tape

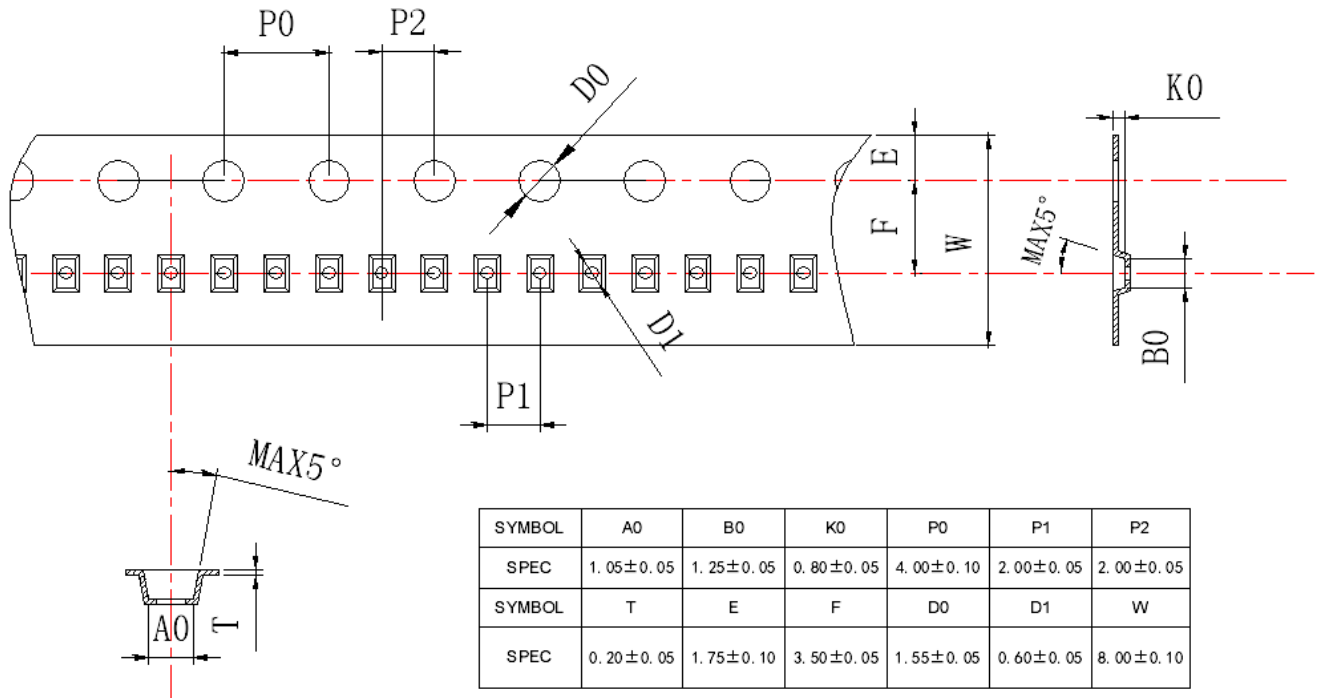

Reel Dimensions

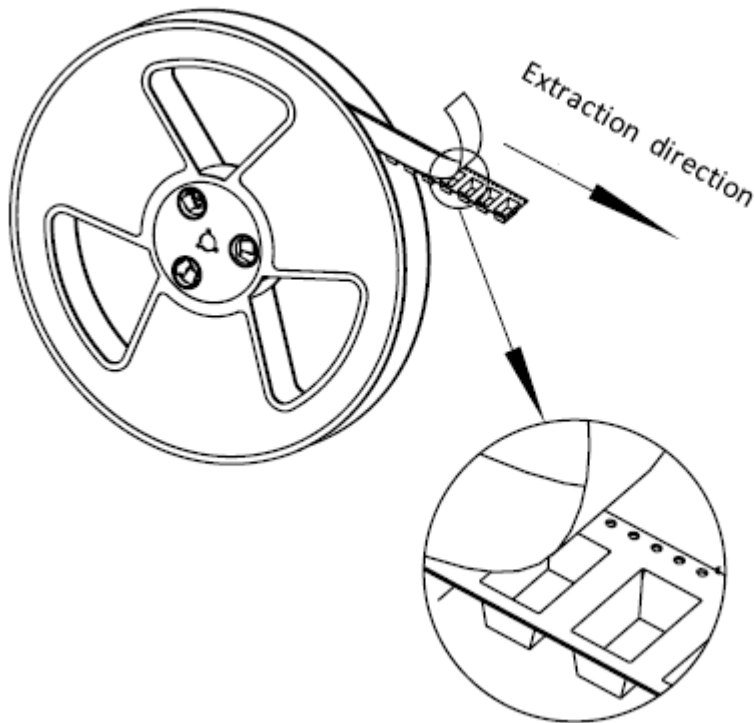

Material	PS
Unit	mm
Tolerance	±0.20 mm
Quantity	10000/reel

Outer Packing

Type	Quantity	Dimension	Description	Weight
Carton Box I	10000	200×200×100	anti-static plastic bag & carton box 1 reel / bag 5 bags / box (50000 pcs) 10 bags / box (100000 pcs)	0.85
Carton Box II	20000	200×200×200		1.80

Unit: mm

Unit: kg

Remarks

- SAW devices should not be used in any type of fluid such as water, oil, organic solvent, etc.
- Be certain not to apply voltage exceeding the rated voltage of components.
- Do not operate outside the recommended operating temperature range of components.
- Sudden change of temperature shall be avoided, deterioration of the characteristics can occur.
- Be careful of soldering temperature and duration of components when soldering.
- Do not place soldering iron on the body of components.
- Be careful not to subject the terminals or leads of components to excessive force.
- SAW devices are electrostatic sensitive. Please avoid static voltage during operation and storage.
- Ultrasonic cleaning shall be avoided. Ultrasonic vibration may cause destruction of components.

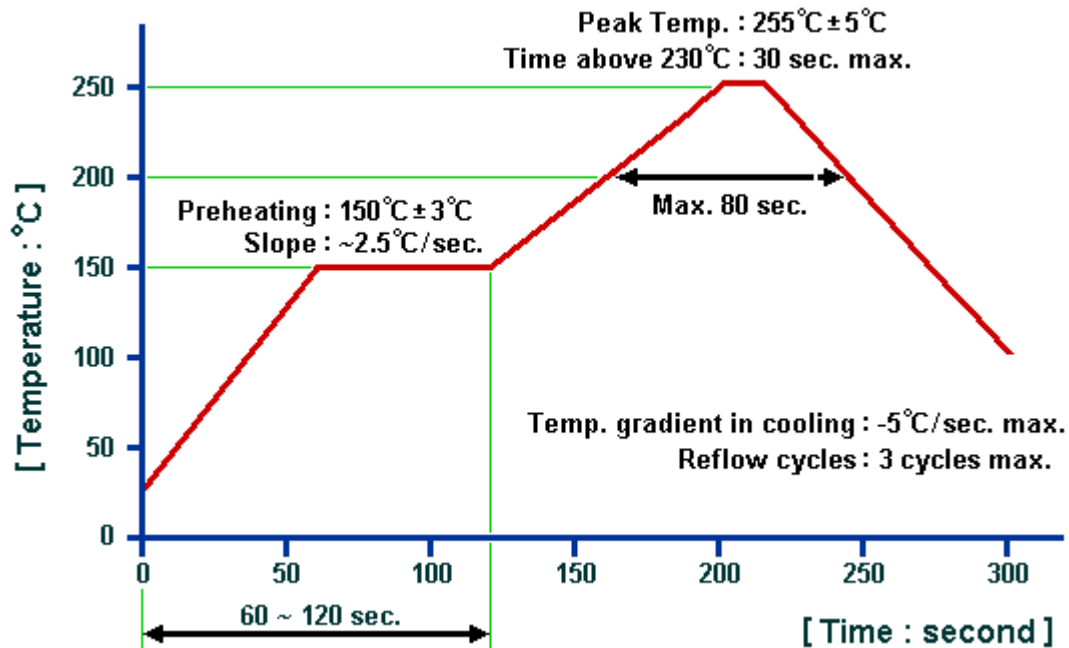
Recommended Soldering Profile

© DGHUAYING 2016. All Rights Reserved.

1. The specifications of this device are subject to change or obsolescence without notice.
2. Typically, equipment utilizing this device requires emissions testing and government approval, which is the responsibility of the equipment manufacturer.
3. Our liability is only assumed for the Surface Acoustic Wave (SAW) component(s) per se, not for applications, processes and circuits implemented within components or assemblies.
4. For questions on technology, prices and delivery, please contact our sales offices or e-mail sales@dghuaying.com.