

SOT-23 Plastic-Encapsulate MOSFETS

FEATURE

- High power and current handing capability
- Lead free product is acquired
- Surface mount package

APPLICATION

- Battery Switch
- DC/DC Converter

MARKING: S10

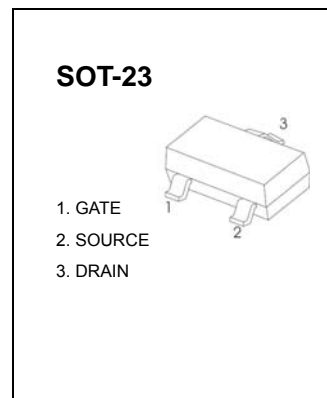
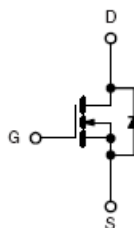

Maximum ratings ($T_a=25^{\circ}\text{C}$ unless otherwise noted)

Parameter	Symbol	Value	Unit
Drain-Source Voltage	V_{DS}	60	V
Gate-Source Voltage	V_{GS}	± 20	V
Continuous Drain Current	I_D	3	A
Pulsed Drain Current (note 1)	I_{DM}	10	A
Power Dissipation	P_D	0.35	W
Thermal Resistance from Junction to Ambient (note 2)	$R_{\theta JA}$	357	$^{\circ}\text{C/W}$
Junction Temperature	T_J	150	$^{\circ}\text{C}$
Storage Temperature	T_{STG}	-55~+150	$^{\circ}\text{C}$

SOT-23 Plastic-Encapsulate MOSFETS

Electrical characteristics (T_a=25°C unless otherwise noted)

Parameter	Symbol	Test Condition	Min	Typ	Max	Unit
STATIC CHARACTERISTICS						
Drain-source breakdown voltage	V _{(BR)DSS}	V _{GS} = 0V, I _D = 250μA	60			V
Zero gate voltage drain current	I _{DSS}	V _{DS} = 60V, V _{GS} = 0V			1	μA
Gate-body leakage current	I _{GSS}	V _{GS} = ±20V, V _{DS} = 0V			±100	nA
Gate threshold voltage (note 3)	V _{GS(th)}	V _{DS} = V _{GS} , I _D = 250μA	0.5		2	V
Drain-source on-resistance (note 3)	R _{DS(on)}	V _{GS} = 10V, I _D = 3A			105	mΩ
		V _{GS} = 4.5V, I _D = 3A			125	mΩ
Forward tranconductance (note 3)	g _{FS}	V _{DS} = 15V, I _D = 2A	1.4			S
Diode forward voltage (note 3)	V _{SD}	I _S = 3A, V _{GS} = 0V			1.2	V
DYNAMIC CHARACTERISTICS (note 4)						
Input Capacitance	C _{iss}	V _{DS} = 30V, V _{GS} = 0V, f = 1MHz		247		pF
Output Capacitance	C _{oss}			34		pF
Reverse Transfer Capacitance	C _{rss}			19.5		pF
SWITCHING CHARACTERISTICS (note 4)						
Turn-on delay time	t _{d(on)}	V _{GS} = 10V, V _{DD} = 30V, I _D = 1.5A, R _{GEN} = 1Ω		6		ns
Turn-on rise time	t _r			15		ns
Turn-off delay time	t _{d(off)}			15		ns
Turn-off fall time	t _f			10		ns
Total Gate Charge	Q _g	V _{DS} = 30V, V _{GS} = 4.5V, I _D = 3A		6		nC
Gate-Source Charge	Q _{gs}			1		nC
Gate-Drain Charge	Q _{gd}			1.3		nC

Notes :

1. Repetitive rating : Pulse width limited by junction temperature.
2. Surface mounted on FR4 board , t_s ≤ 10s.
3. Pulse Test : Pulse Width ≤ 300μs, Duty Cycle ≤ 0.5%.
4. Guaranteed by design, not subject to producing.

SOT-23 Plastic-Encapsulate MOSFETS

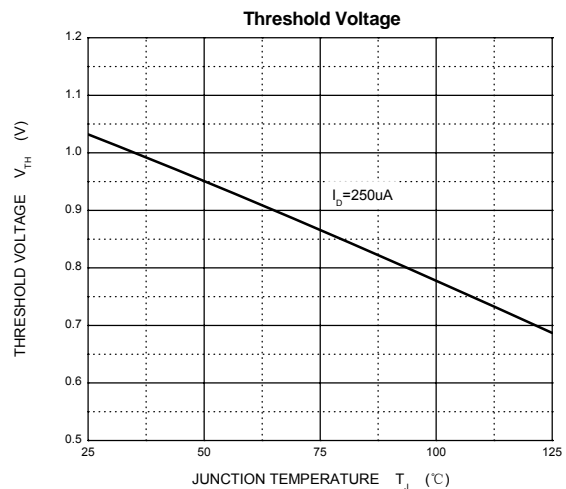
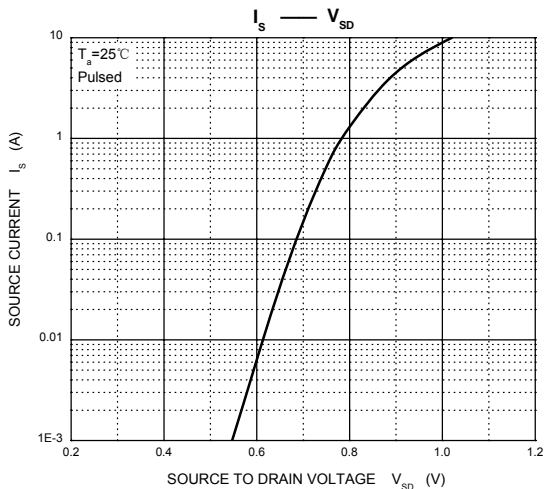
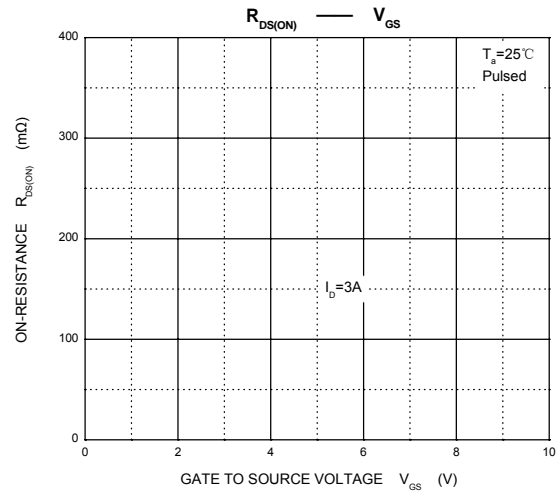
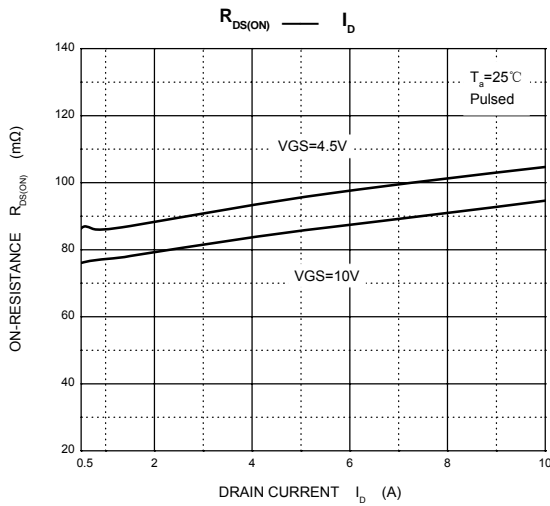
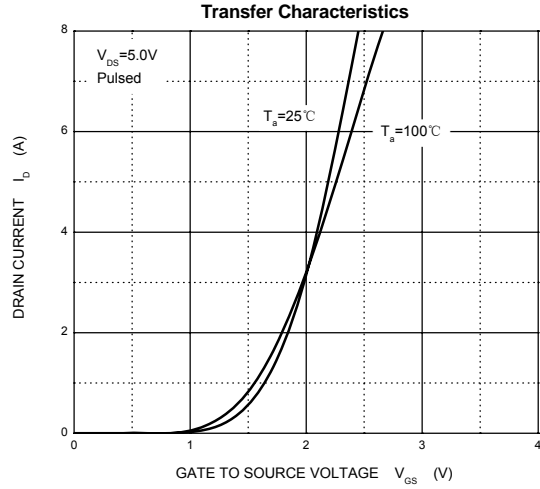
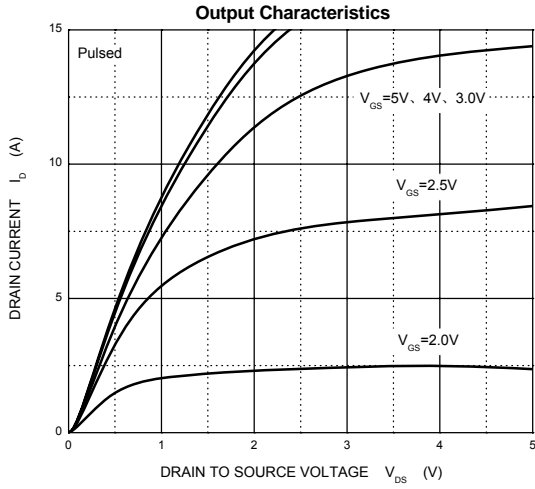

SOT-23 Plastic-Encapsulate MOSFETS

SOT-23 Package Outline Dimensions

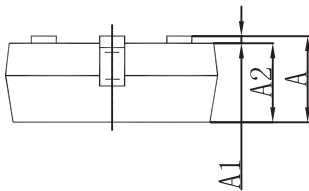
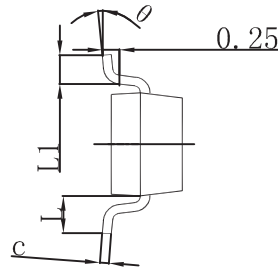
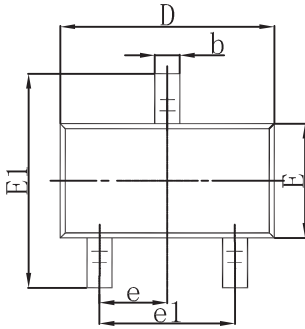

Symbol	Dimensions In Millimeters		Dimensions In Inches	
	Min	Max	Min	Max
A	0.900	1.150	0.035	0.045
A1	0.000	0.100	0.000	0.004
A2	0.900	1.050	0.035	0.041
b	0.300	0.500	0.012	0.020
c	0.080	0.150	0.003	0.006
D	2.800	3.000	0.110	0.118
E	1.200	1.400	0.047	0.055
E1	2.250	2.550	0.089	0.100
e	0.950 TYP		0.037 TYP	
e1	1.800	2.000	0.071	0.079
L	0.550 REF		0.022 REF	
L1	0.300	0.500	0.012	0.020
θ	0°	8°	0°	8°

SOT-23 Suggested Pad Layout

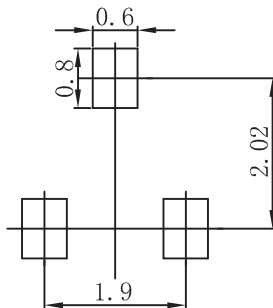

Note:

1. Controlling dimension: in millimeters.
2. General tolerance: $\pm 0.05\text{mm}$.
3. The pad layout is for reference purposes only.