



SPECIFICATION

Surface Acoustic Wave Filter

USER



USER PART No.

SEMCO PART No. **SFHG56BA002**

DOC. No. SMS-51-L-SFT-FX-56

DATE March 13, 2014

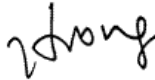
REVISION 000

| WISOL | | | | | |
|-----------|---|-------------------|---|------------------|---|
| ISSUED BY | Kim, Young-Hun  | APPROVED BY (R&D) | Hong, Seong-Su  | APPROVED BY (QC) | Choi, Jae hyeong  |
| User | | | | | |
| ISSUED BY | | CHECKED BY | | APPROVED BY | |

WISOL CO., LTD.
531-7, Gajang-ro, Osan-si,
Gyeonggi-do, KOREA, 447-210
<http://www.wisol.co.kr>

▶ A TABLE OF CONTENTS

| | |
|---|----|
| 1. REVISION HISTORY | 3 |
| 2. DEFINITION | 4 |
| 3. PRECAUTIONS | 4 |
| 4. OUTLINE DRAWING & DIMENSIONS | 5 |
| 5. MARKING | 6 |
| 6. PERFORMANCE | 7 |
| 6-1. MAXIMUM RATINGS | 7 |
| 6-2. ELECTRICAL CHARACTERISTICS | 8 |
| 7. RELIABILITY | 10 |
| 7-1. ENGINEERING SAMPLE FLOW CHART | 10 |
| 7-2. TEST ITEM & CONDITION | 11 |
| 8. REFLOW CONDITION | 12 |
| 9. RECOMMENDED PCB DIMENSIONS | 12 |
| 10. CAUTION | 13 |
| 11. PACKING | 14 |
| 11-1. DIMENSIONS | 14 |
| 11-2. REELING QUANTITY | 15 |
| 11-3. TAPING STRUCTURE | 15 |
| 11-4. INNER BOX(Reel Packing) STRUCTURE | 16 |
| 11-5. OUTER BOX STRUCTURE | 17 |
| 12. TAPE SPECIFICATIONS | 18 |
| 13. RoHS DATA | 19 |

1. REVISION HISTORY

| | | | |
|-----|----------------|----------|--------------------|
| 000 | March 13, 2014 | All Page | Make specification |
|-----|----------------|----------|--------------------|

2. DEFINITION

2-1. PART No.

S F H G 5 6 B A 0 0 2

① ② ③ ④ ⑤ ⑥

| No. | EXPLANATION |
|-----|--|
| ① | SAW Filter |
| ② | Design Type |
| ③ | Center Frequency : 2655MHz (2620MHz ~ 2690MHz) |
| ④ | Input:50ohm,Output:50ohm |
| ⑤ | Package size: 1.1×0.9mm ² |
| ⑥ | Design Revision (02 : Molding Type) |

2-2. APPLICATION : Band-Pass Filter for LTE Band7 Rx etc.

3. PRECAUTIONS

3-1. This device should not be used in any type of fluid such as water, oil, organic solvent, etc.

3-2. This is a hermetic device.

MSL(Moisture Sensitive Level) is the '2a' level.

3-3. Ultrasonic cleaning shall be avoided.

3-4. Isopropyl Alcohol and Ethyl Alcohol can be used for cleaning. Contact us before using other cleaning solvents than above

3-5. This is an electrostatic sensitive device.

Please avoid static voltage during operation and storage.

3-6. Sudden change of temperature shall be avoided, deterioration of the characteristics can occur.

3-7. If any malfunction due to designing or manufacturing which is out of specification occurs within one year after the products have been delivered, the maker should exchange the defective products.

4. OUTLINE DRAWING & DIMENSIONS

[Unit: mm]

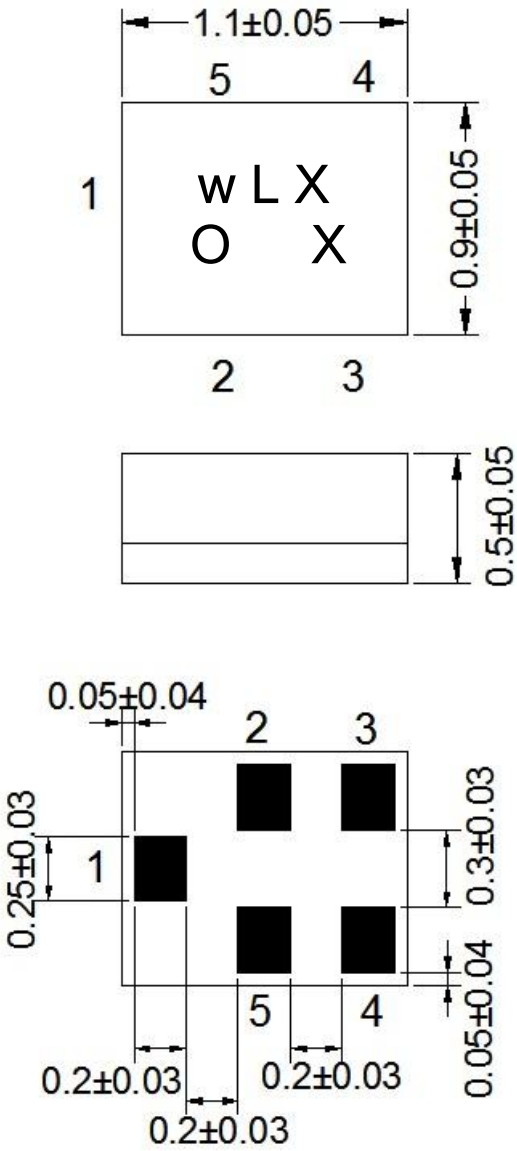

| No. | Function |
|---------|-------------------|
| 2, 3, 5 | Ground |
| 1 | Unbalanced Input |
| 4 | Unbalanced Output |

5. MARKING

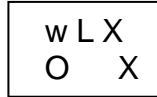

5-1. w L X X

- The 1st 2nd character 'wL' indicates the model name of SAW Filter SFHG56BA002.
- The 3rd character 'X' indicates the year and the month of manufacture.

| Year | Month | | | | | | | | | | | |
|------|-------|---|---|---|---|---|---|---|---|----|----|----|
| | 1 | 2 | 3 | 4 | 5 | 6 | 7 | 8 | 9 | 10 | 11 | 12 |
| 2013 | P | Q | R | S | T | U | V | W | X | Y | Z | a |
| 2014 | 1 | 2 | 3 | 4 | 5 | 6 | 7 | 8 | 9 | A | B | C |
| 2015 | D | E | F | G | H | I | J | K | L | M | N | O |
| 2016 | P | Q | R | S | T | U | V | W | X | Y | Z | a |

※ This rotates by the 3 years.

- The 4th character 'X' indicates Lot No.

5-2. ○

- This symbol indicates input pin 1.
- This indicates the producing center
 - : China

5-3. Marking : Laser Marking

6. PERFORMANCE

6-1. MAXIMUM RATINGS

| CHARACTERISTICS | RATINGS | UNITS |
|-----------------------------|------------|-------|
| DC Permissive Voltage | 5 | V |
| Maximum Input Power | 15 | dBm |
| Operating Temperature Range | - 30 ~ +85 | °C |
| Storage Temperature Range | - 40 ~ +85 | °C |

6-2. ELECTRICAL CHARACTERISTICS
6-2-1. TABLE

Ta = - 30 ~ +85℃

| Item | FREQUENCY RANGE [MHz] | UNIT | SPECIFICATION | | |
|-----------------------|-----------------------|---|---------------|------------|------|
| | | | Min. | Typ. (25℃) | Max. |
| Insertion Loss | 2620 ~ 2690 | dB | - | 1.85 | 3.0 |
| Inband Ripple | 2620 ~ 2690 | dB | - | 0.4 | 1.5 |
| Input VSWR | 2620 ~ 2690 | - | - | 1.8 | 2.3 |
| Output VSWR | 2620 ~ 2690 | - | - | 1.8 | 2.3 |
| Absolute Attenuation | DC ~ 2380 | dB | 30 | 36 | - |
| | 2380 ~ 2500 | dB | 33 | 41 | - |
| | 2500 ~ 2570 | dB | 35 | 43 | - |
| | 2775 ~ 3000 | dB | 20 | 25 | - |
| | 3000 ~ 4300 | dB | 28 | 35 | - |
| | 4300 ~ 6000 | dB | 25 | 31 | - |
| Termination Impedance | | Input: Unbalanced 50 ohm Output: Unbalanced 50 ohm | | | |

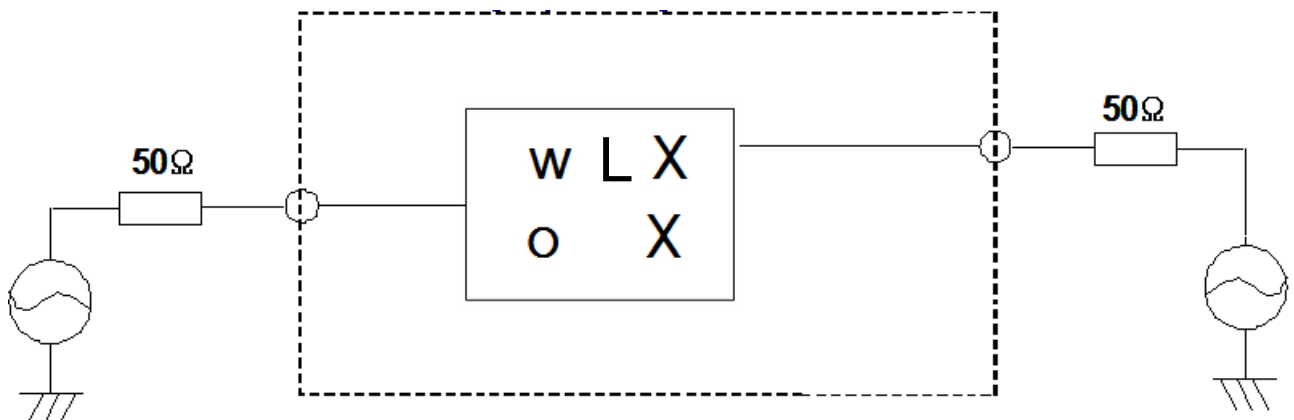
6-2-2. TEST FIXTURE

[X-Ray Top View]

6-2-3. GRAPH

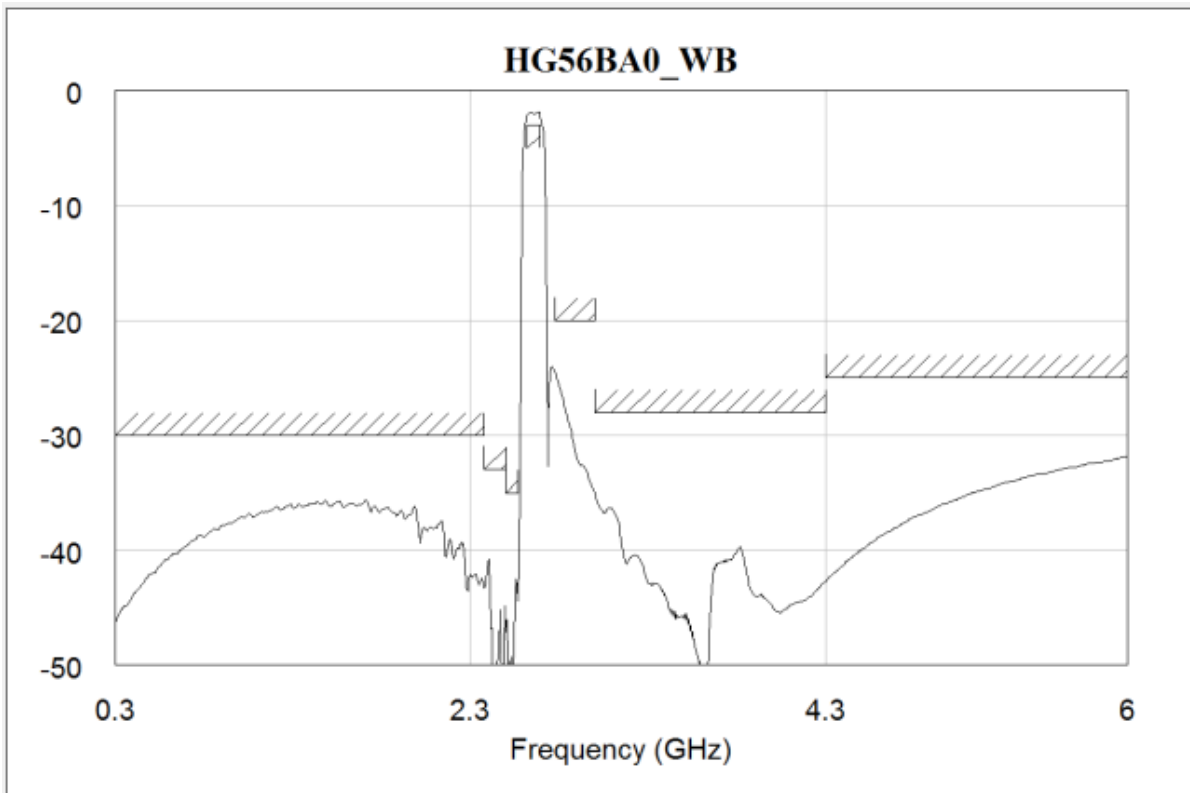
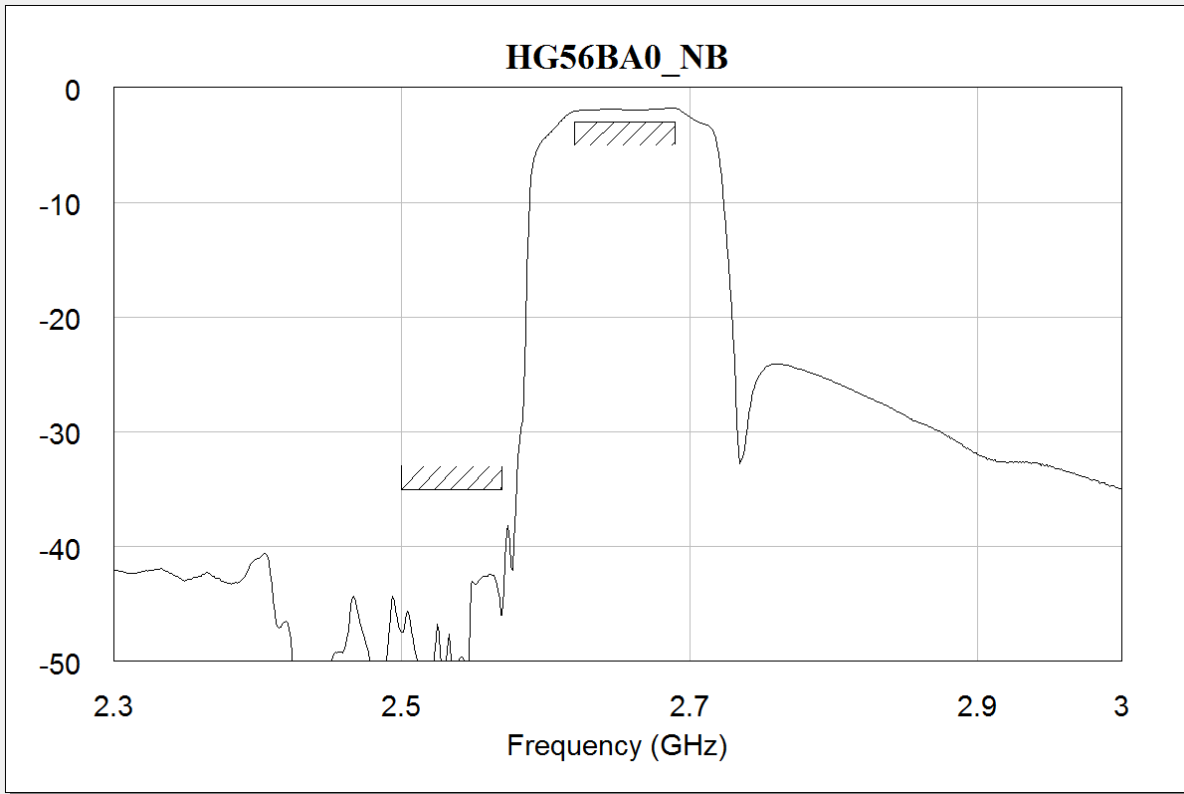

7. RELIABILITY

7-1. ENGINEERING SAMPLE FLOW CHART

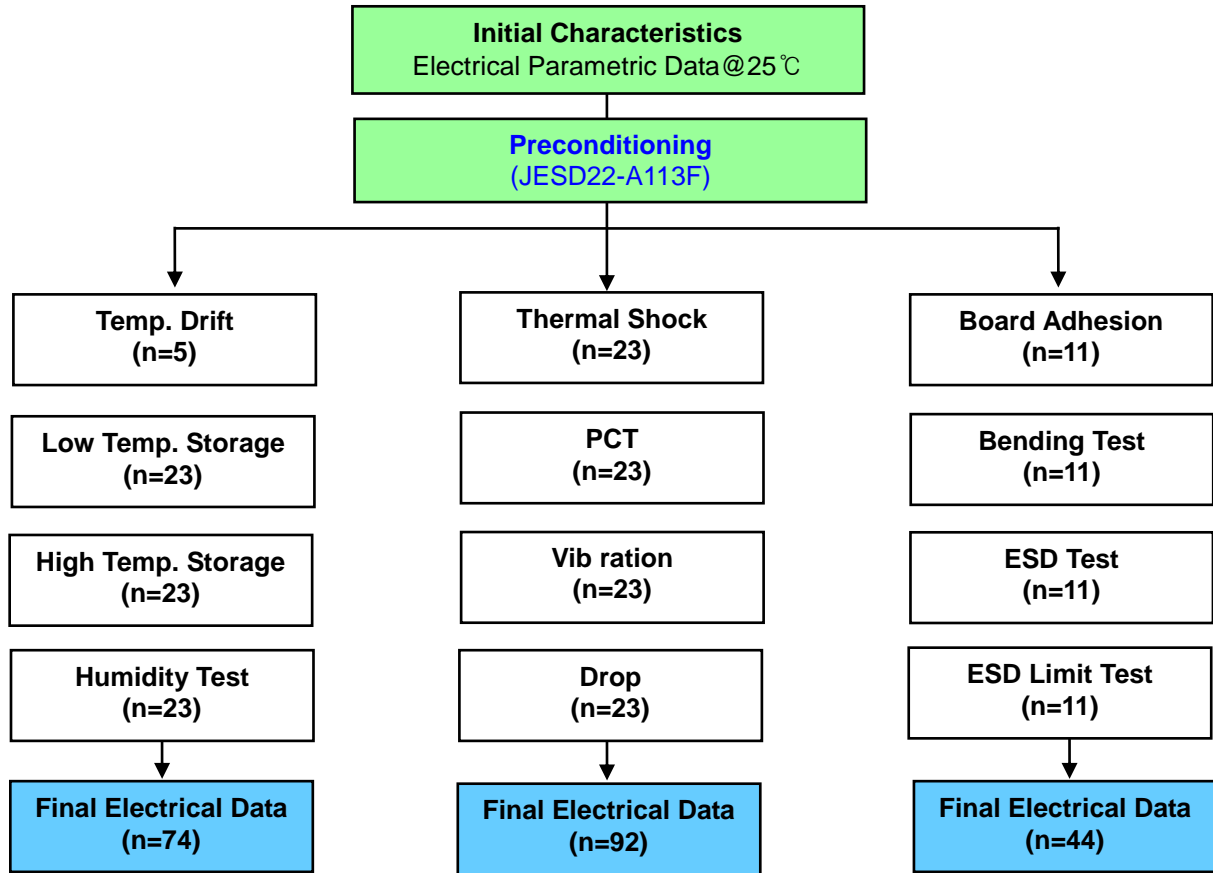

7-2. TEST ITEM & CONDITION

| CATEGORY | TEST ITEM | TEST CONDITION | REMARK |
|----------|-----------------|---|-------------|
| | Preconditioning | +125℃ 24hr Baking → +60℃ 60%RH 120hr → Reflow Test(3times) | JESD22A113F |



| | | | |
|------------------|----------------------------------|--|------------------|
| Environment Test | Temp. Drift | -30℃ → +25℃ → +85℃ | description |
| | High Temp. Storage | +85℃ 240hr | JESD22-A103C |
| | Low Temp. Storage | -40℃ 240hr | JESD22-A119 |
| | High Temp. High Humidity Storage | +85℃ 85%RH 240hr | JESD22-A106B |
| | Thermal Shock | -40℃/30min ⇔ +85℃/30min , 100cycle | JESD22-A106A |
| | High Temp. Operating | +121℃ 100%RH 96hr | JESD22-A102C |
| Mechanical Test | Vibration Test (Random) | 20 Hz~2000 Hz,0.053G ² /Hz or 8gs RMS,15min/plane | IEC 68-2-36 Fdb |
| | Drop Test | 152 cm 12times Steel floor JIG(110g~150g) | IEC 1178-1.4.8.9 |
| | Board Adhesion | 0.5 mm/sec 1point push | IEC 68-2-21 Ue3 |
| | Bending Test | 0.5 mm/sec 3times -PCB : FR4 , PCB SIZE : 100*40 mm | IEC 68-2-21 Ue3 |
| Physical Test | Solder Heat Resistance | ±250V,C=100pF,R=1.5 kΩ, 1times | IEC 68-2-21 Ue3 |
| | static marginal test | C=100pF,R=1.5 kΩ, 1times(demand of customer) | JESD22-A114F |

8. REFLOW CONDITION

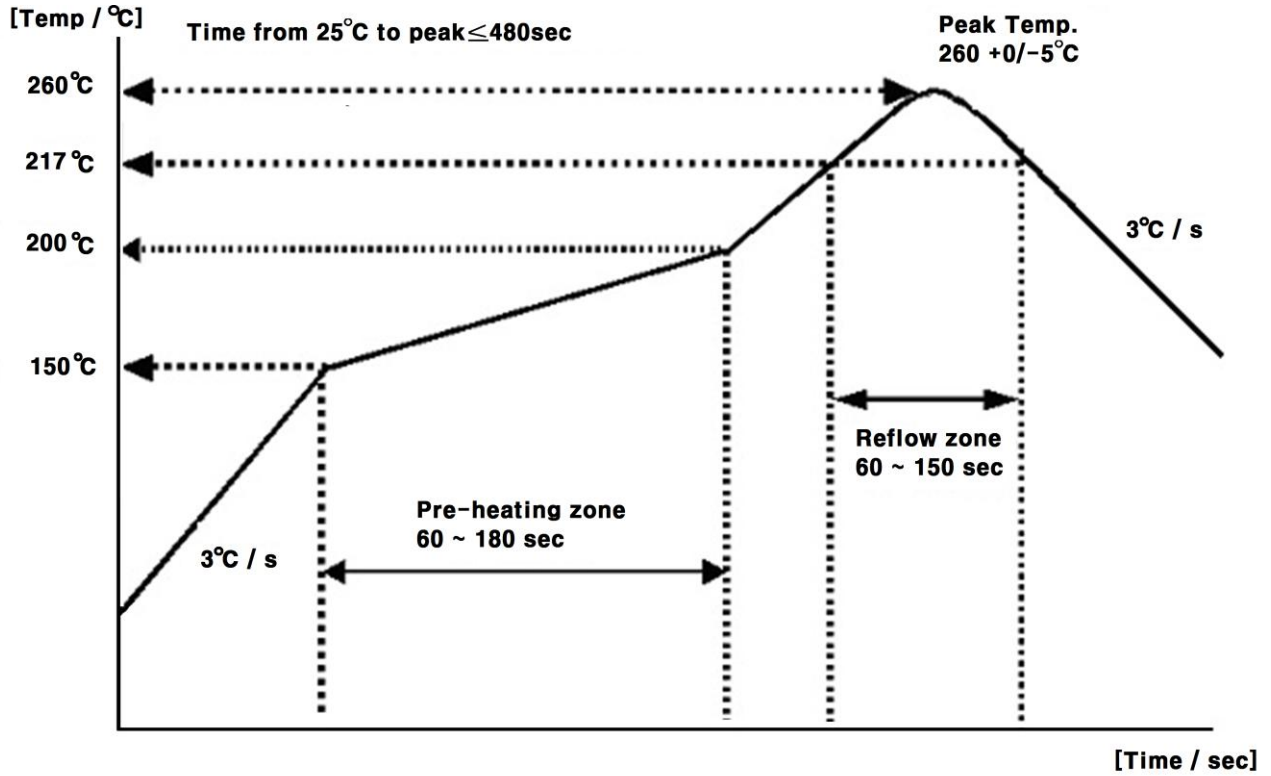

9. RECOMMENDED PCB DIMENSIONS

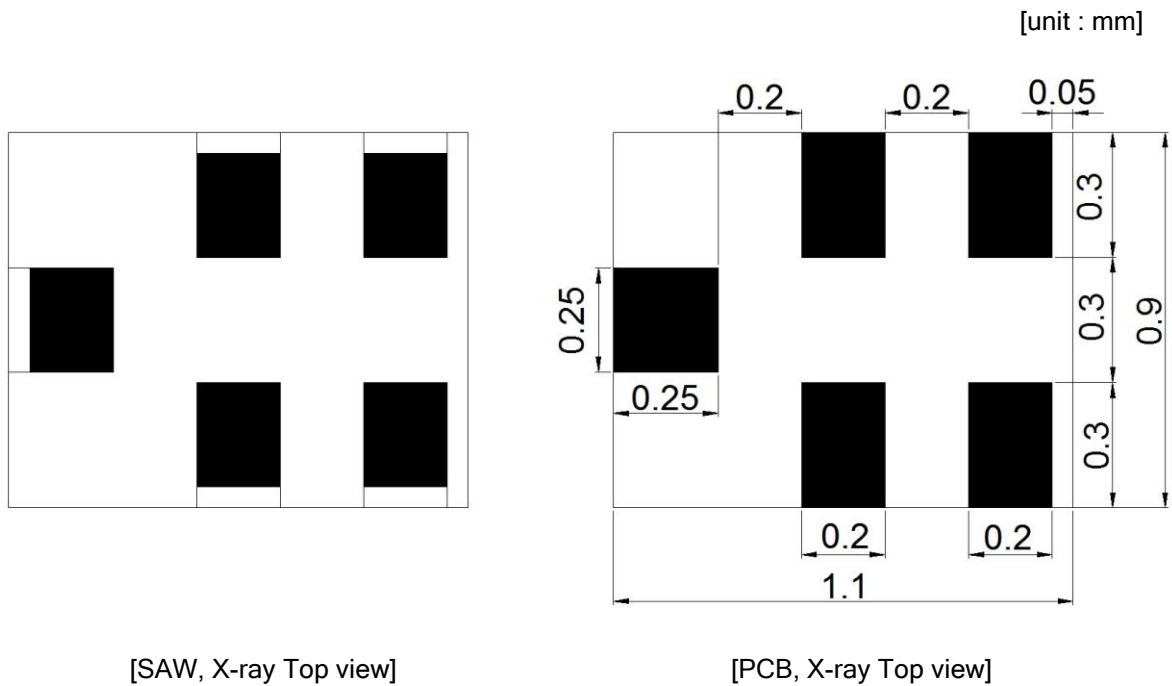

10. CAUTION

Moisture Sensitivity Device Caution (MSL LEVEL=2a)

1. Calculated shelf life in sealed bag : 12 month at < 40°C and < 90% relative Humidity(RH)
 2. Peak package body temperature : **260°C**
 3. After bag is opened, devices that will be subjected to reflow solder or other high temperature process must be
 - (a) Mounted within : 672 hours of factory conditions ≤30°C/60% RH, or
 - (b) Stored per J-STD-033
 4. Device require bake, before mounting, if :
 - (a) Humidity Indicator Card reads > 60% when read at 23±5°C
 - (b) 3(a) or 3(b) are not met
 5. If baking is required, refer to IPC/JEDEC J-STD-033 for bake procedure
- Note : Level and body temperature defined by IPC/JEDEC J-STD-020

Aluminum Pack (310mmX370mm)



HIC(Humidity Indication Card)

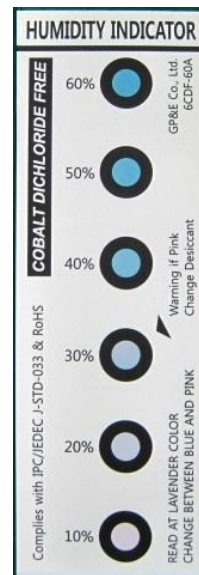

10 to 60% RH

11. PACKING

11-1. DIMENSIONS

- Carrier Tape

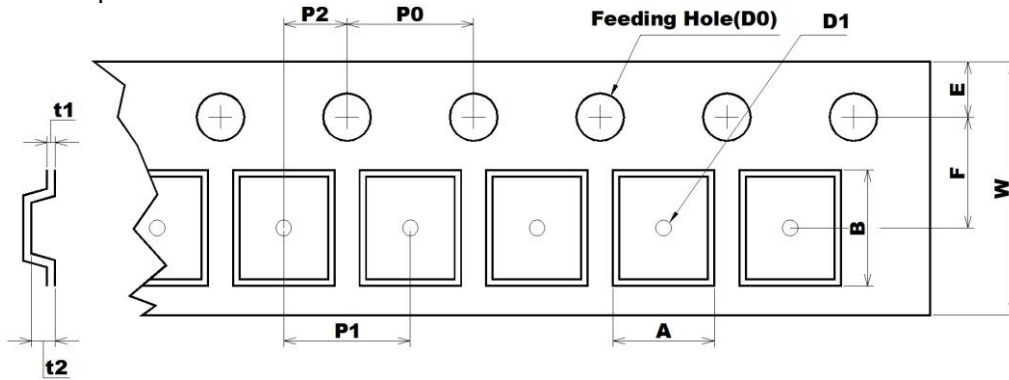

[Unit: mm]

| A | B | D0 | D1 | E | F | P0 | P1 | P2 | t1 | t2 | W |
|-------|-------|-------|-------|-------|-------|-------|-------|-------|-------|-------|-------|
| 1.10 | 1.35 | Ø1.50 | Ø0.50 | 1.75 | 3.50 | 4.00 | 4.00 | 2.00 | 0.25 | 0.70 | 8.00 |
| +0.05 | +0.05 | +0.10 | +0.05 | +0.10 | +0.05 | +0.10 | +0.10 | +0.05 | +0.02 | +0.05 | +0.30 |
| -0.05 | -0.05 | -0.00 | -0.05 | -0.10 | -0.05 | -0.10 | -0.10 | -0.05 | -0.02 | -0.05 | -0.10 |

- Reel

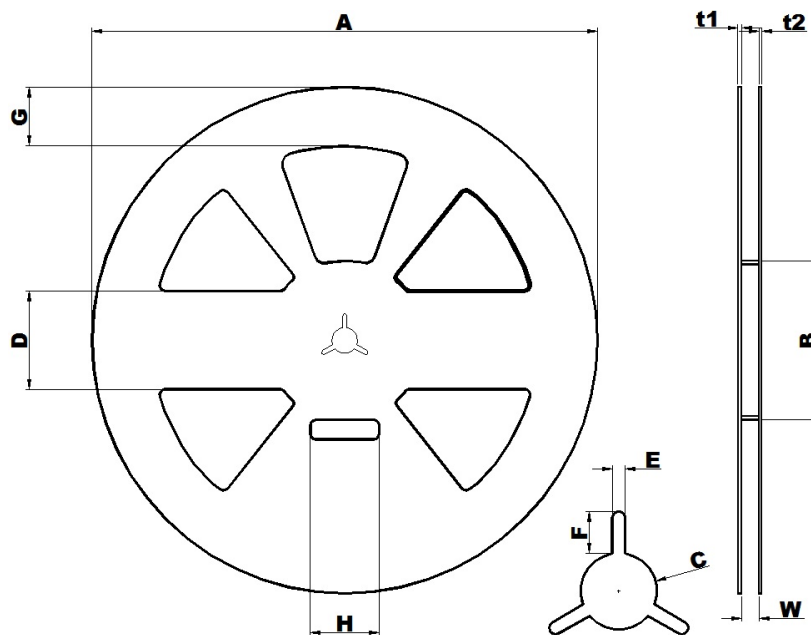

[Unit: mm]

| A | B | C | D | E | F | G | H | t1 | t2 | W |
|--------|-------|-------|------|------|------|------|------|------|------|------|
| Ø258.0 | Ø81.0 | Ø13.0 | 50.0 | 2.2 | 7.0 | 30.0 | 35.0 | 1.8 | 1.5 | 9.0 |
| +1.0 | +1.0 | +0.5 | +0.8 | +0.3 | +0.5 | +0.8 | +1.0 | +0.5 | +0.5 | +1.0 |
| -0.5 | -1.0 | -0.5 | -0.8 | -0.3 | -0.5 | -0.8 | -1.0 | -0.5 | -0.5 | -0.5 |

- The product shall be packed properly not to damaged during transportation and storage.

11-2. REELING QUANTITY

10 inch reel : 10,000 pcs/reel

11-3. TAPING STRUCTURE

11-3-1. The tape shall be wound around the reel in direction shown below.

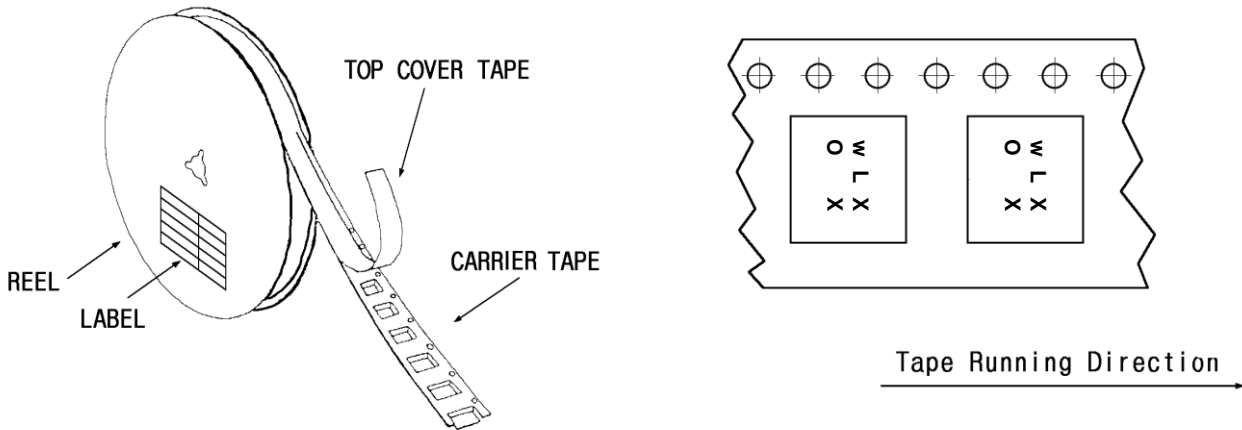

11-3-2. BAR CODE LABEL

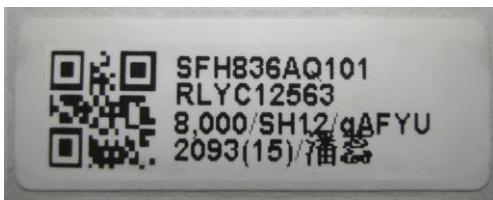

- | | |
|--|--|
| <ul style="list-style-type: none"> ①  ② SFH836AQ101 ③ RLYC12563 ④ 8,000 / qAFYU | <p>MODEL NAME BARCODE</p> <p>Model Name</p> <p>Reel number</p> <p>Quantity / Marking</p> |
|--|--|

1-3-3. Leader part and vacant position specifications.

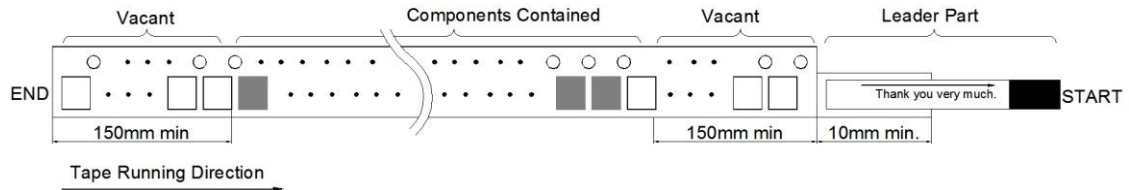

11-4. INNER BOX(Reel Packing) STRUCTURE

Material: Polycarbonate

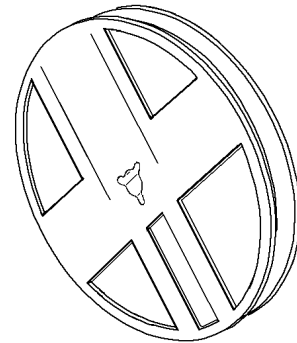

Material : Polyethylene + Aluminium
Size : 310×370mm²

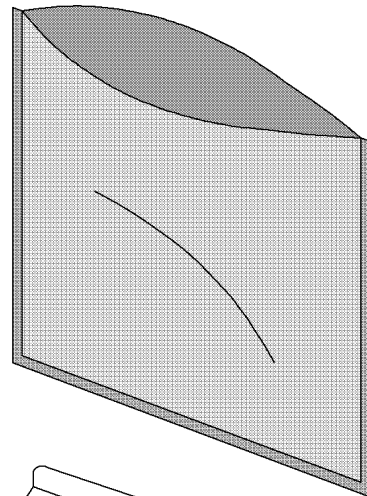

Material : Paper
Size: (D)260×(W)37×(H)265mm³

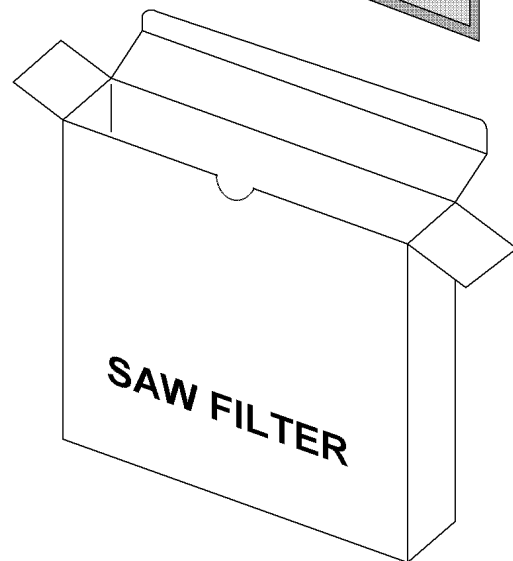

11-5. OUTER BOX STRUCTURE

Material : Paper

| TYPE | SIZE(mm) | | | Inner Box # |
|------|----------|-----|-----|-------------|
| | a | b | c | |
| A | 270 | 240 | 275 | 6 boxes |

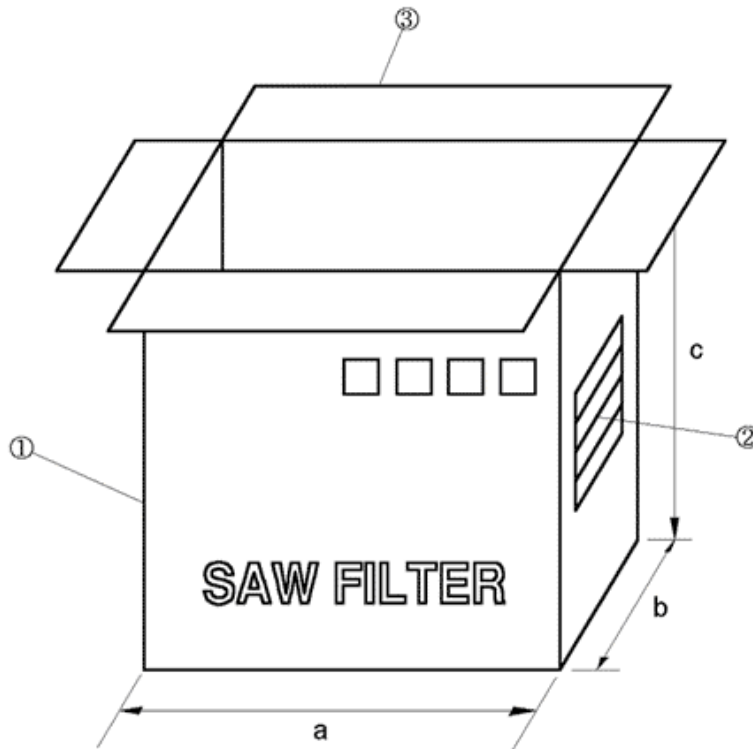

SIDE ①

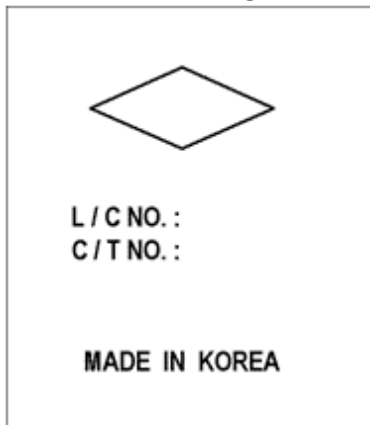

SIDE ②

| | |
|-------|-------|
| MODEL | |
| Q'TY | EA |
| USER | |
| DATE | . . . |

- SIDE is the same as front side.

12. TAPE SPECIFICATIONS

12-1. Tensile Strength of Carrier Tape: 4.4N/mm width

12-2. Top Cover Tape Adhesion (See the below figure)

- pull of angle: 0~15 degree
- speed: 300mm/min.
- force: 20~70g

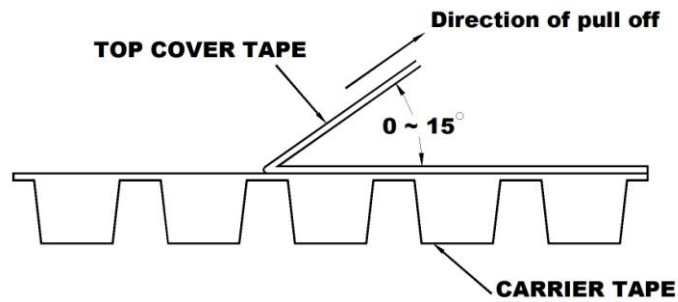

13. RoHS DATA



Test Report No. F690101/LF-CTSAYAA13-31939

Issued Date: 2013. 07. 08 Page 1 of 6

To: **WISOL CO., LTD.**
 373-7
 Gajang-dong
 Osan-si
 Gyeonggi-do
 Korea

The following merchandise was submitted and identified by the client as :

| | |
|--------------------------|---|
| SGS File No. | : AYAA13-31939 |
| Product Name | : SAW FILTER |
| Item No./Part No. | : N/A |
| Received Date | : 2013. 07. 03 |
| Test Period | : 2013. 07. 04 to 2013. 07. 08 |
| Buyer(s) | : SAMSUNG |
| Test Results | : For further details, please refer to following page(s) |
| Test Performed | : SGS Korea tested the sample(s) selected by applicant with following results. |
| Test Comments | : By the applicant's specific request, the sampling and testing was performed only for the part indicated in the photo without disassembly. |

Timothy Jeon
 Jinhee Kim
 Cindy Park
 Jerry Jung/ Testing Person

SGS Korea Co., Ltd.



Jeff Jang / Chemical Lab Mgr

Document is issued by the Company subject to its General Conditions of Service which are available on request or accessible at <http://www.sgs.com/Document/Conditions.aspx> and, for electronic format documents, subject to Terms and Conditions for Electronic Documents at <http://www.sgs.com/Document/Conditions.aspx>. Attention is drawn to the limitation of liability, indemnification and jurisdiction issues defined therein. Any issue of the document is subject that information contained herein reflects the Company's findings at the time of its intervention only and within the limits of Client's instructions. If the Company's tests (requirements) do not identify a defect, the document does not constitute a warranty or a transaction from existing at that time and obligations under the transaction document. The document cannot be reproduced, stored in full, without prior written approval of the Company. Any unauthorized alteration, copy or distribution of the content of any document is prohibited and Offenders may be prosecuted to the fullest extent of the law. All references stated the results shown in this test report refer only to the sample(s) tested and each sample(s) are retained for 30 days only.

SGS Korea Co., Ltd.

322, The O valley, 555-8, Hoge-dong, Dongan-gu, Anyang-si, Gyeonggi-do, Korea 431-080
 t +82 (0)31 4808 000 f +82 (0)31 4808 059 <http://www.sgs.kor.com> www.kr.sgs.com/greenlab

D52 Version5

Member of the SGS Group (Société Générale de Surveillance)



Test Report No. F690101/LF-CTSAYAA13-31939

Issued Date: 2013. 07. 08 Page 2 of 8

Sample No. : AYAA13-31939.001
Sample Description : SAW FILTER
Item No./Part No. : N/A
Materials : N/A

Heavy Metals

| Test Items | Unit | Test Method | MDL | Results |
|-----------------------------|-------|---|-----|---------|
| Cadmium (Cd) | mg/kg | With reference to IEC 62321:2008, ICP | 0.5 | N.D. |
| Lead (Pb) | mg/kg | With reference to IEC 62321:2008, ICP | 5 | N.D. |
| Mercury (Hg) | mg/kg | With reference to IEC 62321:2008, ICP | 2 | N.D. |
| Hexavalent Chromium (Cr VI) | mg/kg | With reference to IEC 62321:2008, UV-VIS | 1 | N.D. |
| Antimony (Sb) | mg/kg | With reference to EPA 3052(1996), US EPA 6010B(1996), ICP | 10 | N.D. |

Flame Retardants-PBBs/PBDEs

| Test Items | Unit | Test Method | MDL | Results |
|--------------------------|-------|---|-----|---------|
| Monobromobiphenyl | mg/kg | With reference to IEC 62321:2008, GC-MS | 5 | N.D. |
| Dibromobiphenyl | mg/kg | With reference to IEC 62321:2008, GC-MS | 5 | N.D. |
| Tribromobiphenyl | mg/kg | With reference to IEC 62321:2008, GC-MS | 5 | N.D. |
| Tetrabromobiphenyl | mg/kg | With reference to IEC 62321:2008, GC-MS | 5 | N.D. |
| Pentabromobiphenyl | mg/kg | With reference to IEC 62321:2008, GC-MS | 5 | N.D. |
| Hexabromobiphenyl | mg/kg | With reference to IEC 62321:2008, GC-MS | 5 | N.D. |
| Heptabromobiphenyl | mg/kg | With reference to IEC 62321:2008, GC-MS | 5 | N.D. |
| Octabromobiphenyl | mg/kg | With reference to IEC 62321:2008, GC-MS | 5 | N.D. |
| Nonabromobiphenyl | mg/kg | With reference to IEC 62321:2008, GC-MS | 5 | N.D. |
| Decabromobiphenyl | mg/kg | With reference to IEC 62321:2008, GC-MS | 5 | N.D. |
| Monobromodiphenyl ether | mg/kg | With reference to IEC 62321:2008, GC-MS | 5 | N.D. |
| Dibromodiphenyl ether | mg/kg | With reference to IEC 62321:2008, GC-MS | 5 | N.D. |
| Tribromodiphenyl ether | mg/kg | With reference to IEC 62321:2008, GC-MS | 5 | N.D. |
| Tetrabromodiphenyl ether | mg/kg | With reference to IEC 62321:2008, GC-MS | 5 | N.D. |
| Pentabromodiphenyl ether | mg/kg | With reference to IEC 62321:2008, GC-MS | 5 | N.D. |
| Hexabromodiphenyl ether | mg/kg | With reference to IEC 62321:2008, GC-MS | 5 | N.D. |
| Heptabromodiphenyl ether | mg/kg | With reference to IEC 62321:2008, GC-MS | 5 | N.D. |
| Octabromodiphenyl ether | mg/kg | With reference to IEC 62321:2008, GC-MS | 5 | N.D. |
| Nonabromodiphenyl ether | mg/kg | With reference to IEC 62321:2008, GC-MS | 5 | N.D. |

NOTE:

- (1) N.D. = Not detected. (<MDL)
- (2) mg/kg = ppm
- (3) MDL = Method Detection Limit
- (4) - = No regulation
- (5) Negative = Undetectable / Positive = Detectable
- (6) ** = Qualitative analysis (No Unit)
- (7) * = Boiling-water-extraction:
 Negative = Absence of CrVI coating
 Positive = Presence of CrVI coating; the detected concentration in boiling-water-extraction solution is equal or greater than 0.02 mg/kg with 50 cm² sample surface area.

The document is issued by the Company subject to its General Conditions of Service printed on each report or available at http://www.sgs.com/conditions_of_service.pdf, for electronic format documents, subject to Terms and Conditions for Electronic Documents at http://www.sgs.com/conditions_of_service_electronic.pdf. Client's attention is drawn to the limitation of liability, indemnification and jurisdiction issues defined therein. Any holder of this document is advised that information contained herein reflects the Company's findings at the time of its intervention only and within the limits of Client's instructions. It will be the Client's sole responsibility to be the Client and the document does not constitute advice in a transaction from existing or future clients and regulators under the transaction documents. This document cannot be reproduced, stored in a retrieval system or transmitted in any form or by any means, electronic, mechanical, photocopying, recording, or by any information storage and retrieval system, without prior written approval of the Company. Any unauthorized alteration, forgery or falsification of the content or appearance of this document is unlawful and offenders may be prosecuted to the fullest extent of the law. Client's attention is drawn to the results shown in this test report refer only to the samples tested and each sample(s) are related to 30 days only.



Test Report No. F690101/LF-CTSAYAA13-31939

Issued Date: 2013. 07. 08 Page 3 of 6

Sample No. : AYAA13-31939.001
Sample Description : SAW FILTER
Item No./Part No. : N/A
Materials : N/A

Flame Retardants-PBBs/PBDEs

| Test Items | Unit | Test Method | MDL | Results |
|-------------------------|-------|---|-----|---------|
| Decabromodiphenyl ether | mg/kg | With reference to IEC 62321:2008, GC-MS | 5 | N.D. |

Halogen Content

| Test Items | Unit | Test Method | MDL | Results |
|--------------|-------|-----------------------|-----|---------|
| Bromine(Br) | mg/kg | BS EN 14582:2007 , IC | 30 | N.D. |
| Chlorine(Cl) | mg/kg | BS EN 14582:2007 , IC | 30 | N.D. |



NOTE:

- (1) N.D. = Not detected.(<MDL)
- (2) mg/kg = ppm
- (3) MDL = Method Detection Limit
- (4) - = No regulation
- (5) Negative = Undetectable / Positive = Detectable
- (6) ** = Qualitative analysis (No Unit)
- (7) * = Boiling-water-extraction:
 Negative = Absence of CrVI coating
 Positive = Presence of CrVI coating; the detected concentration in boiling-water-extraction solution is equal or greater than 0.02 mg/kg with 50 cm2 sample surface area.

This document is issued by the Company subject to its General Conditions of Service (which are available on request or available at <http://www.sgs.com/ClientandConditions.pdf>), its standard format documents, subject to Terms and Conditions for Electronic Documents at <http://www.sgs.com/Service/20130101>. Attention is drawn to the limitation of liability, indemnification and jurisdiction issues defined therein. Any holder of this document is advised that information contained herein reflects the Company's findings at the time of its intervention only and within the limits of Client's instructions. If the Company's work reasonably is to be Client and the document does not constitute notice to a third party from existing or their rights and obligations under the transaction concerned. This document cannot be reproduced except in full, without prior written approval of the Company. Any unauthorized alteration, forgery or falsification of the content or appearance of this document is unlawful and offences may be prosecuted to the fullest extent of the law. Unless otherwise stated the results shown in this test report refer only to the sample(s) tested and each sample(s) are retained for 30 days only.



Test Report No. F690101/LF-CTSAYAA13-31939

Issued Date: 2013. 07. 08 Page 4 of 6

Testing Flow Chart for RoHS:Cd/Pb/Hg/Cr⁶⁺ /PBBs&PBDEs Testing

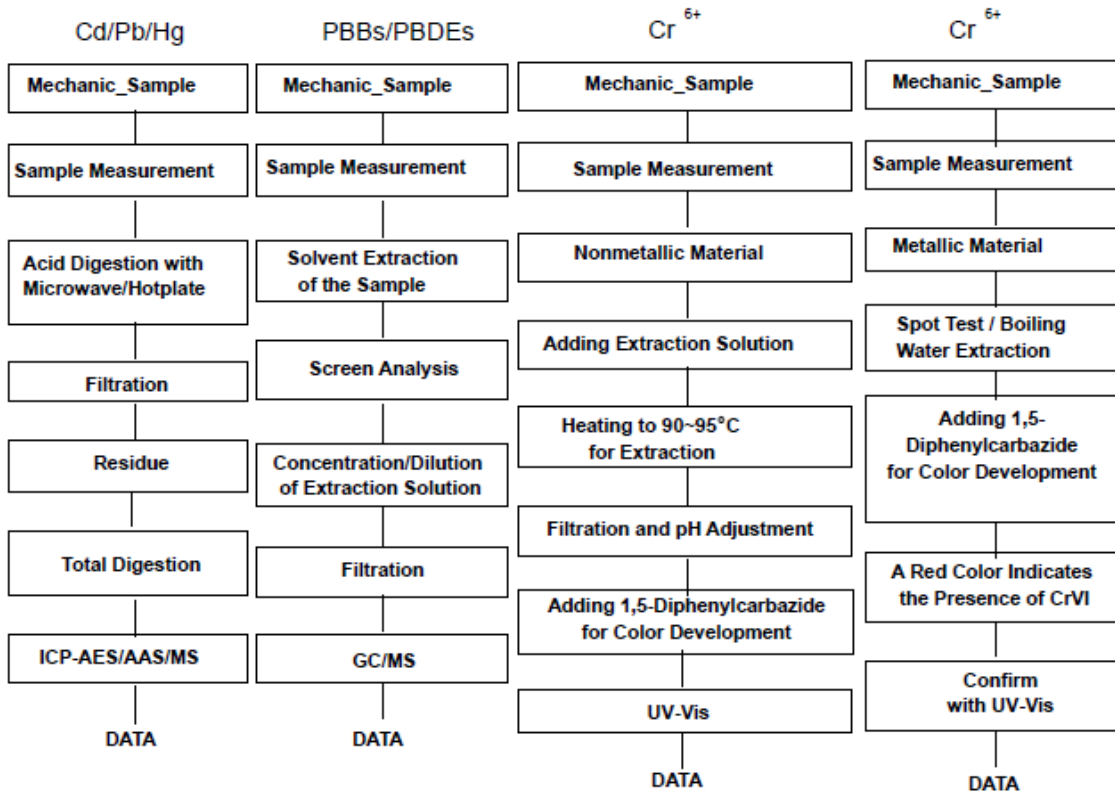

The samples were dissolved totally by pre-conditioning method according to above flow chart for Cd,Pb,Hg.
Section Chief : Gilsae Yi

NOTE:

- (1) N.D. = Not detected.(<MDL)
- (2) mg/kg = ppm
- (3) MDL = Method Detection Limit
- (4) - = No regulation
- (5) Negative = Undetectable / Positive = Detectable
- (6) ** = Qualitative analysis (No Unit)
- (7) * = Boiling-water-extraction:
 Negative = Absence of CrVI coating
 Positive = Presence of CrVI coating; the detected concentration in boiling-water-extraction solution is equal or greater than 0.02 mg/kg with 50 cm² sample surface area.

The document is issued by the Company subject to the General Conditions of Service printed hereafter, available on request or accessible at <http://www.sgs.com/rohsandconflictminerals> and, for electronic format documents, subject to Terms and Conditions for Electronic Documents at <http://www.sgs.com/rohsandconflictminerals>. Attention is drawn to the deletion of liability, indemnification and jurisdiction issues defined therein. Any holder of the document is advised that information contained therein reflects the Company's findings at the time of its intervention only and within the limits of Client's instructions. If any. The Company's sole responsibility is to the Client and this document does not constitute parties to a transaction from assuming all their rights and obligations under the transaction documents. This document cannot be reproduced, stored in a retrieval system, or transmitted in any form or by any means, electronic, mechanical, photocopying, recording, or by any information storage and retrieval system, without prior written approval of the Company. Any unauthorized alteration, forgery or falsification of the content or appearance of this document is illegal and offences may be prosecuted to the fullest extent of the law. (Date otherwise stated the results shown in this test report only apply to the sample(s) tested and each sample(s) are retained for 90 days only.)

F052 Version5

SGS Korea Co.,Ltd.

322, The O valley, 555-8, Hoge-dong, Dongan-gu, Anyang-si, Gyeonggi-do, Korea 431-080
 t +82 (0)31 4608 000 f +82 (0)31 4608 050 <http://www.sgslab.co.kr> www.kr.sgs.com/greenlab

Member of the SGS Group (Société Générale de Surveillance)



Test Report No. F690101/LF-CTSAYAA13-31939

Issued Date: 2013. 07. 08 Page 5 of 6

Flow Chart for Inorganic Elements Testing

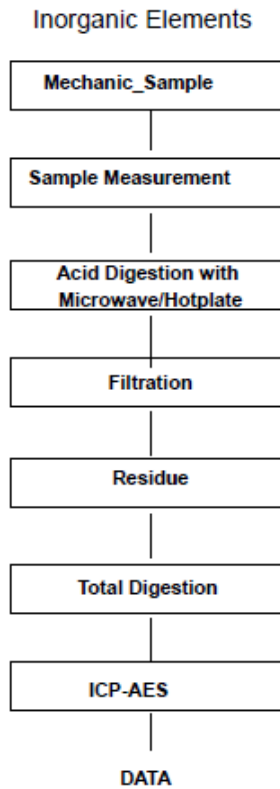

NOTE:

- (1) N.D. = Not detected.(<MDL)
- (2) mg/kg = ppm
- (3) MDL = Method Detection Limit
- (4) - = No regulation
- (5) Negative = Undetectable / Positive = Detectable
- (6) ** = Qualitative analysis (No Unit)
- (7) * = Boiling-water-extraction:
 Negative = Absence of CrVI coating
 Positive = Presence of CrVI coating; the detected concentration in boiling-water-extraction solution is equal or greater than 0.02 mg/kg with 50 cm2 sample surface area.

* Document is issued by the Company subject to the General Conditions of Service printed overleaf available on request or accessible at http://www.sgs.com/conditions_of_service and http://www.sgs.com/conditions_of_service_jpn for electronic format documents, subject to Terms and Conditions for Electronic Documents at http://www.sgs.com/conditions_of_service. Where applicable, reference is made to the location of facility, identification and jurisdiction laws defined therein. Any issue of the document is without prejudice to the Company's liability at the time of its issuance only and within the limits of Chinese jurisdiction. If any modification of the content or appearance of this document is required and therefore may be processed to the fullest extent of the law, the otherwise stated the results shown in this test report refer only to the sample(s) tested and each sample(s) are related to 30 days only.

SGS Korea Co., Ltd.

322, The O valley, 555-8, Hoge-dong, Dongen-gu, Anyang-si, Gyeonggi-do, Korea 431-080
 t +82 (0)31 4608 000 f +82 (0)31 4608 050 <http://www.sgalab.co.kr> www.kr.sgs.com/greenlab

*052 Versions

Member of the SGS Group (Société Générale de Surveillance)



Test Report No. F690101/LF-CTSAYAA13-31939

Issued Date: 2013. 07. 08 Page 6 of 8

Flow Chart for Halogen Test

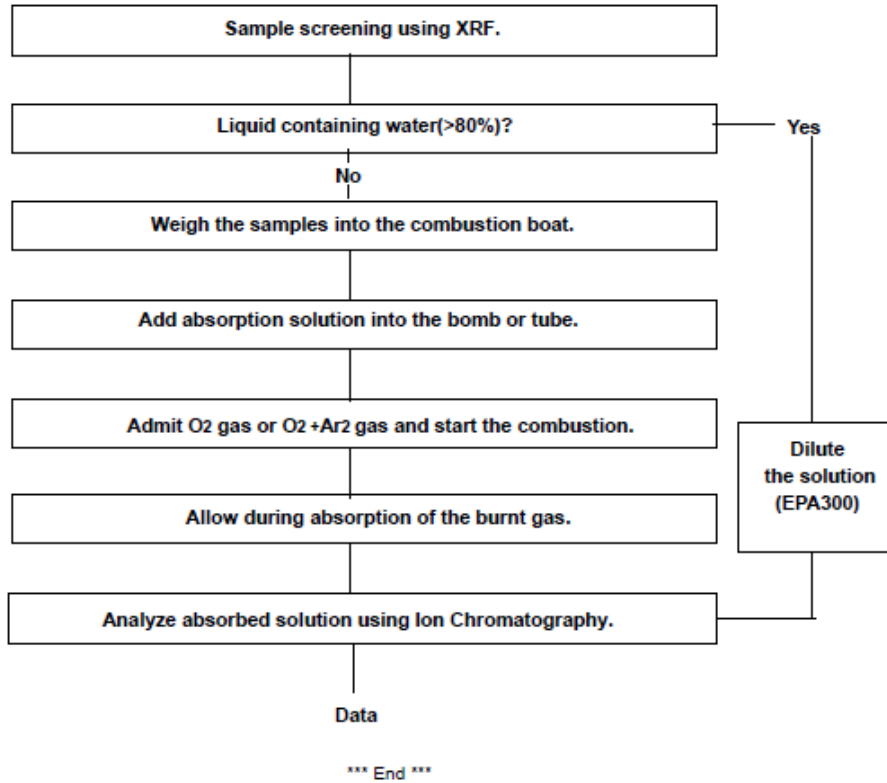

NOTE:

- (1) N.D. = Not detected.(<MDL)
- (2) mg/kg = ppm
- (3) MDL = Method Detection Limit
- (4) - = No regulation
- (5) Negative = Undetectable / Positive = Detectable
- (6) ** = Qualitative analysis (No Unit)
- (7) * = Boiling-water-extraction:
 Negative = Absence of CrVI coating
 Positive = Presence of CrVI coating; the detected concentration in boiling-water-extraction solution is equal or greater than 0.02 mg/kg with 50 cm2 sample surface area.

This document is issued by the Company subject to its General Conditions of Service which are available on request or accessible at http://www.sgs.com/ProductsandServices/sgs_lab for electronic format documents, subject to Terms and Conditions for Electronic Documents at http://www.sgs.com/ProductsandServices/sgs_lab. Attention is drawn to the limitation of liability, indemnification and jurisdiction clauses defined therein. Any value of the document is subject to the information contained therein which is the Company's findings at the time of its issuance only and within the limits of Client's instructions. It is the Company's sole responsibility to its Client and this document does not constitute parties to a transaction from assuming all their rights and obligations under the transaction documents. This document cannot be reproduced except in full, without prior written approval of the Company. Any unauthorized alteration, copy or falsification of the content or appearance of this document is unlawful and offenders may be prosecuted to the fullest extent of the law. These observations apply to the results shown in this test report and only to the associated test and shall not apply to any other test.

F052 Version5

SGS Korea Co.,Ltd.

322, The O valley, 555-9, Hoggys-dong, Daejeon-gu, Anyang-si, Gyeonggi-do, Korea 431-080
 t +82 (0)31 4608 000 f +82 (0)31 4608 050 <http://www.sgs.com/sgslab> www.kr.sgs.com/sgslab

Member of the SGS Group (Société Générale de Surveillance)