

The ESD5Z5.0CT is designed to protect voltage sensitive components from ESD. Excellent clamping capability, low leakage, and fast response time provide best in class protection on designs that are exposed to ESD. Because of its small size, it is suited for use in cellular phones, MP3 players, digital cameras and many other portable applications where board space comes at a premium.

It has been specifically designed to protect sensitive components which are connected to data and transmission lines from overvoltage caused by ESD(electrostatic discharge), and EFT (electrical fast transients).

Features

- Peak Power Dissipation – 200 W (8 x 20 us Waveform)
- Replacement for MLV (0603)
- Protects I/O Port
- Low Clamping Voltage
- Low Leakage
- Low Body Height: 1.68mm
- Response Time is < 1 ns
- Stand-off Voltage: 5.0 V
- RoHS Compliant
- Meets MSL 1 Requirements
- Solid-state silicon avalanche technology
- ROHS compliant
- Device Meets MSL 1 Requirements
- WeiPan technology

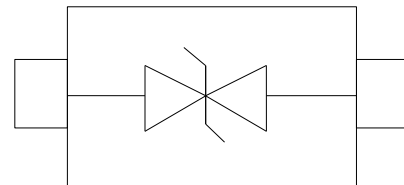

SOD-523

Main applications

- Cellular handsets and accessories
- Portable instrumentation
- Peripherals
- Serial and Parallel Ports
- Notebooks, Desktops, Servers
- Projection TV

Protection solution to meet

- IEC61000-4-2 (ESD) $\pm 15\text{kV}$ (air), $\pm 8\text{kV}$ (contact)
- IEC61000-4-4 (EFT) 40A (5/50ns)

Transient Voltage Suppressors for ESD Protection
Maximum ratings (Tamb=25°C Unless Otherwise Specified)

Parameter	Symbol	Value	Unit
Peak Pulse Power (tp=8/20µs waveform)	P _{PPP}	200	Watts
ESD Rating per IEC61000-4-2:	Contact	8	KV
	Air	15	
Lead Soldering Temperature	T _L	260 (10 sec.)	°C
Operating Temperature Range	T _I	-55 ~ 150	°C
Storage Temperature Range	T _{STG}	-55 ~ 150	°C
Lead Solder Temperature – Maximum (10 Second Duration)	T _L	260	°C

Maximum ratings are those values beyond which device damage can occur. Maximum ratings applied to the device are individual stress limit values (not normal operating conditions) and are not valid simultaneously. If these limits are exceeded, device functional operation is not implied, damage may occur and reliability may be affected.

*Other voltages may be available upon request.

1. Non-repetitive current pulse, per Figure 1.

Electrical characteristics (Tamb=25°C Unless Otherwise Specified)

Device	V _{RWM}	I _R @ V _{RWM}	V _{BR} @ 1 mA	V _C	Capacitance	
			(Volts)	@ 5A	@ V _R = 0 V, 1 MHz (pF)	
	(V)	(µA)	Min	(V)	Typ	Max
ESD5Z5.0CT	5.0	1	5.6	12	15	25

Junction capacitance is measured in VR=0V, F=1MHz

Symbol	Parameter
V _{RWM}	Working Peak Reverse Voltage
V _{BR}	Breakdown Voltage @ I _T
V _C	Clamping Voltage @ I _{PP}
I _T	Test Current
I _{RM}	Leakage current at V _{RWM}
I _{PP}	Peak pulse current
C _O	Off-state Capacitance
C _J	Junction Capacitance

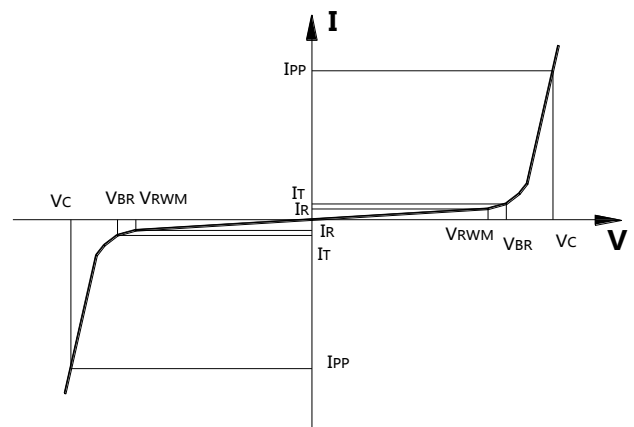

Typical electrical characterist applications

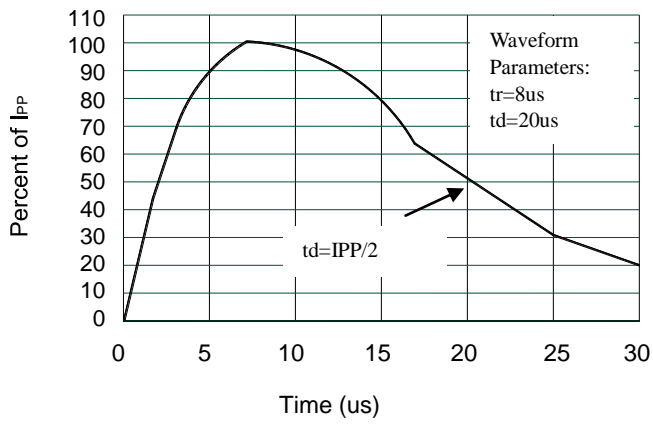

Pulse Waveform

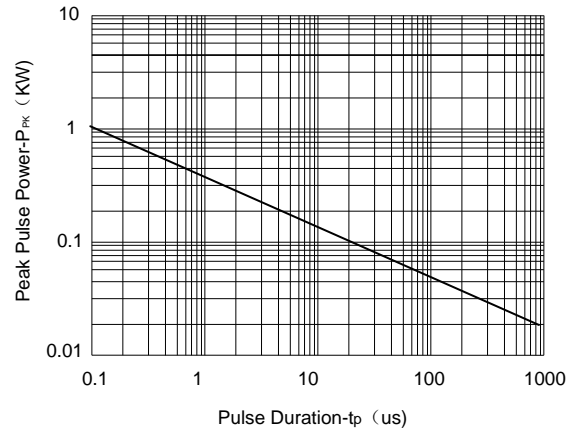

Non-Repitative Peak Pulse Power vs. Pulse Time

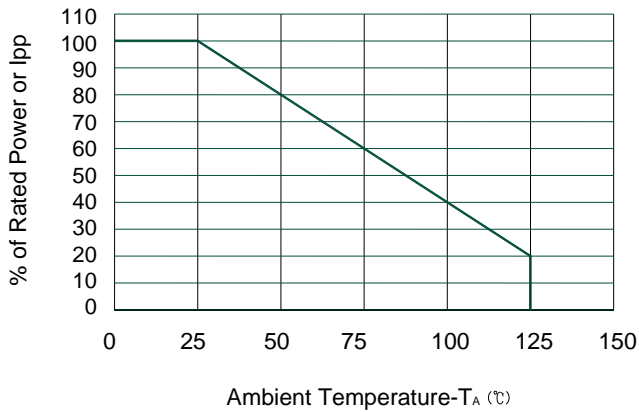

Power Derating Curve

Package Information
SOD-523
Mechanical Data

Case: SOD-523

Case Material: Molded Plastic. UL Flammability

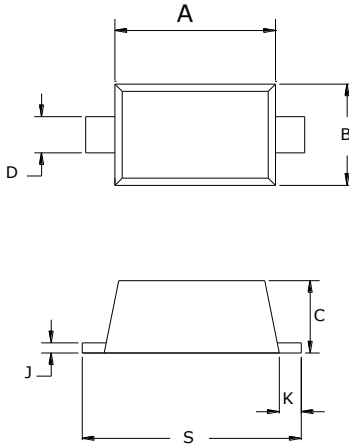

Dim	Millimeters		Inches	
	Min	Max	Min	Max
A	1.10	1.30	0.043	0.051
B	0.75	0.85	0.03	0.033
C	0.51	0.70	0.02	0.028
D	0.25	0.35	0.01	0.014
J	0.08	0.15	0.003	0.006
K	0.15	0.25	0.006	0.010
S	1.50	1.70	0.059	0.067

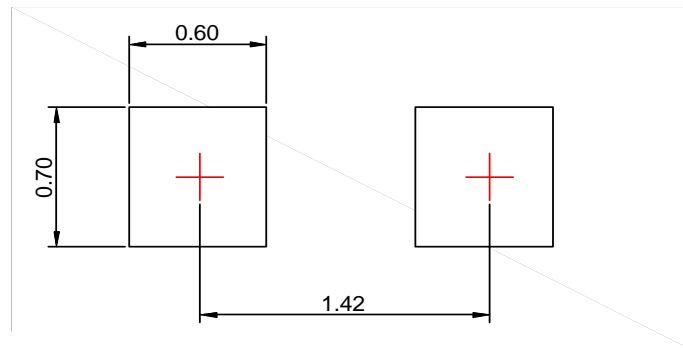
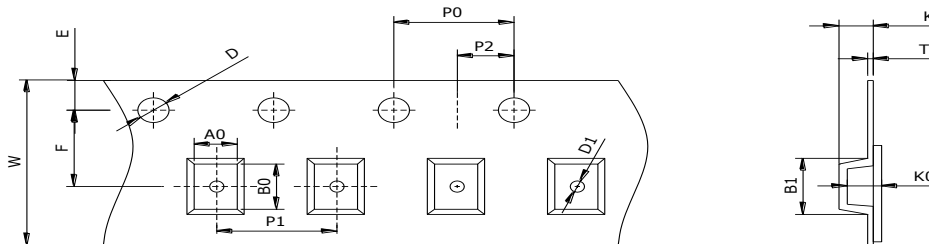
Recommended Pad outline

SOD-523 Reel Dim

Package	Chip Size	Pocket Size B0×A0×K0(mm)	Tape Width	Reel Diameter	Quantity Per Reel	P0	P1
SOD-523	1.70×0.80×0.70	1.90×0.90×0.80	8mm	178mm(7")	3000	4mm	4mm
D0	D1	E	F	K	T	W	
1.5mm	1.0mm	1.75mm	3.5mm	0.75mm	0.2mm	8mm	