

SED4060G

N-Channel Enhancement-Mode MOSFET

Revision: A

General Description

This type used advanced trench technology and design to provide excellent RDS(ON) with low gate charge. It can be used in a wide variety of application

Features

For a single MOSFET

- $V_{DS} = 40V$
- $R_{DS(ON)} = 7m\Omega @ V_{GS}=10V$

Pin configurations

See Diagram below

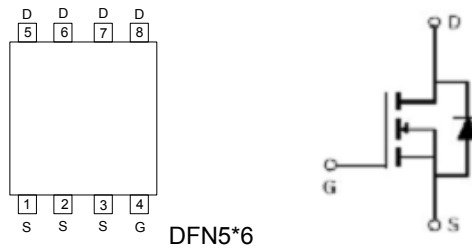

Absolute Maximum Ratings

Parameter	Symbol	Rating	Units
Drain-Source Voltage	V_{DS}	40	V
Gate-Source Voltage	V_{GS}	± 20	V
Drain Current	Continuous	60	A
	Pulsed	200	
Total Power Dissipation	@TA=25°C	65	W
Operating Junction Temperature Range	T_J	-55 to 175	°C

Thermal Resistance

Symbol	Parameter	Typ	Max	Units
$R_{\theta JC}$	Thermal Resistance Junction to Case	-	5	°C/W

SED4060G

Electrical Characteristics (T _J =25°C unless otherwise noted)						
Symbol	Parameter	Test Conditions	Min	Typ	Max	Units
OFF CHARACTERISTICS (Note 2)						
B _V DSS	Drain-Source Breakdown Voltage	I _D =250μA, V _{GS} =0 V	40			V
I _{DSS}	Drain to Source Leakage Current	V _{DS} =40V, V _{GS} =0V			1	μA
I _{GSS}	Gate-Body Leakage Current	V _{GS} =20V			300	nA
V _{GS(th)}	Gate Threshold Voltage	V _{DS} = V _{GS} , I _D =250μA	1.0	1.6	2.2	V
R _{DS(ON)}	Static Drain-Source On-Resistance	V _{GS} =10V, I _D =20A	-	7.5	9.5	mΩ
g _{FS}	Forward Transconductance	V _{DS} =5V, I _D =20A		25		S
DYNAMIC PARAMETERS						
C _{iss}	Input Capacitance	V _{GS} =0V, V _{DS} =20V, f=1MHz		942		pF
C _{oss}	Output Capacitance			309		pF
C _{rss}	Reverse Transfer Capacitance			29		pF
SWITCHING PARAMETERS						
Q _g	Total Gate Charge	V _{GS} =10V, V _{DS} =20V, I _D =10A		14.5		nC
Q _{gs}	Gate Source Charge			2		nC
Q _{gd}	Gate Drain Charge			2.5		nC
t _{d(on)}	Turn-On Delay Time	V _{GS} =10V, V _{DS} =20V, R _{GEN} =10Ω, I _D =10A		6		ns
t _{d(off)}	Turn-Off Delay Time			21		ns
t _{d(r)}	Turn-On Rise Time			5		ns
t _{d(f)}	Turn-Off Fall Time			5		ns
Source-Drain Ratings and Characteristics						
V _{SD}	Diode Forward Voltage	V _{GS} =0V, I _S =20A			1.2	V
t _{rr}	Reverse Recovery Time	T _J =25°C, I _F =10A Di/dt=100A/μs		24		ns
Q _{rr}	Reverse Recovery Charge				19	

Typical Characteristics

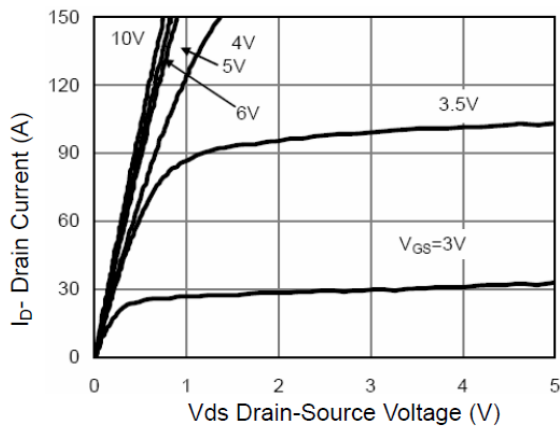

Figure 1 Output Characteristics

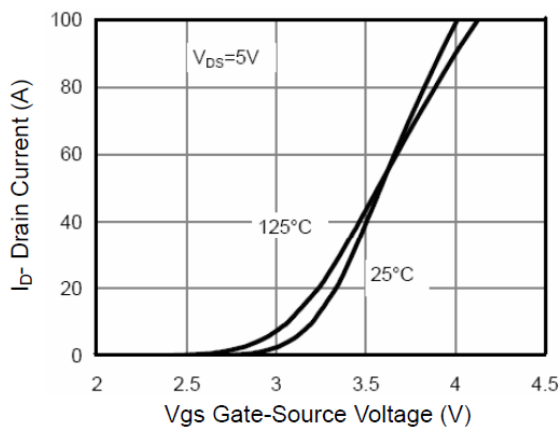

Figure 2 Transfer Characteristics

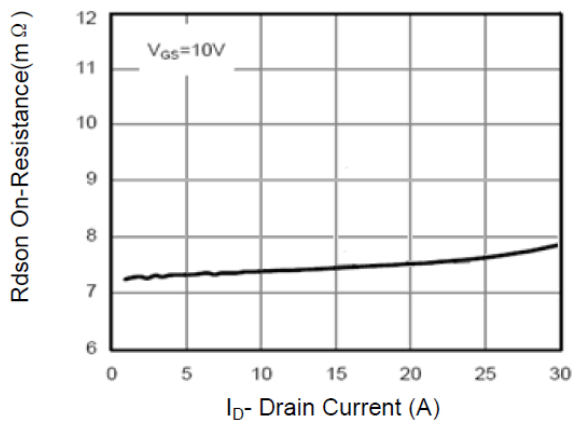

Figure 3 $R_{DS(on)}$ - Drain Current

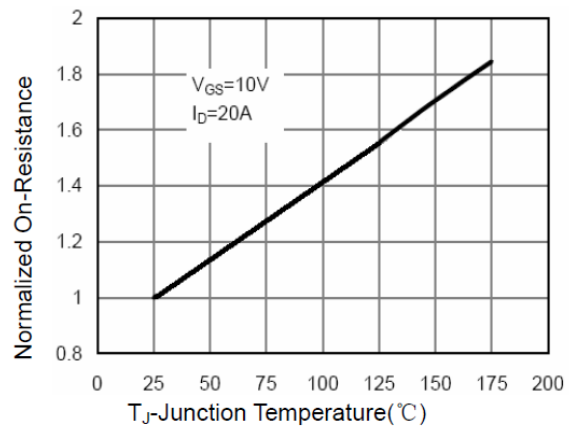

Figure 4 $R_{DS(on)}$ -Junction Temperature

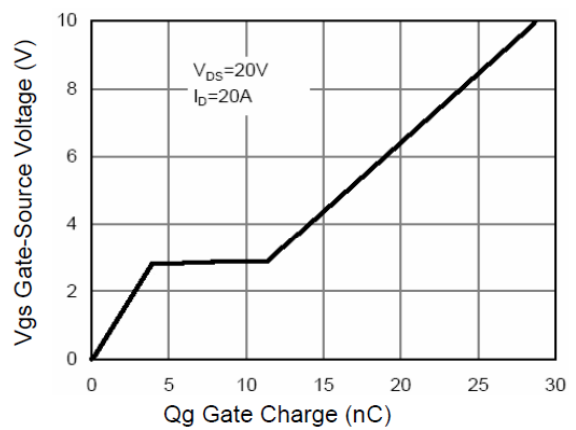

Figure 5 Gate Charge

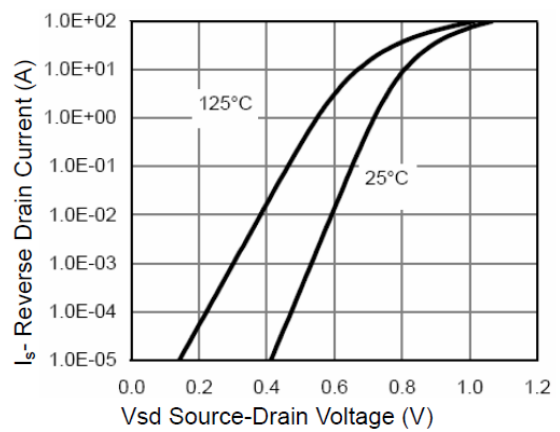

Figure 6 Source- Drain Diode Forward

Typical Characteristics

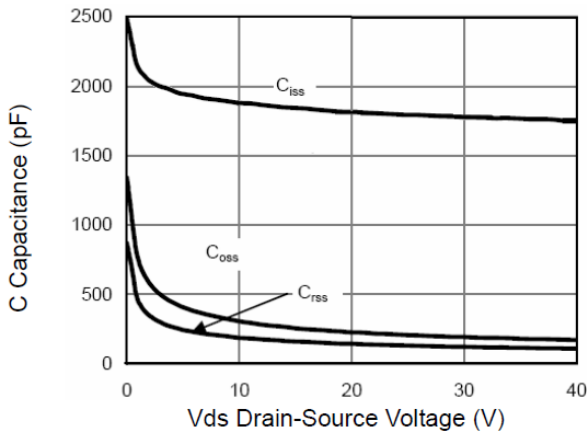

Figure 7 Capacitance vs Vds

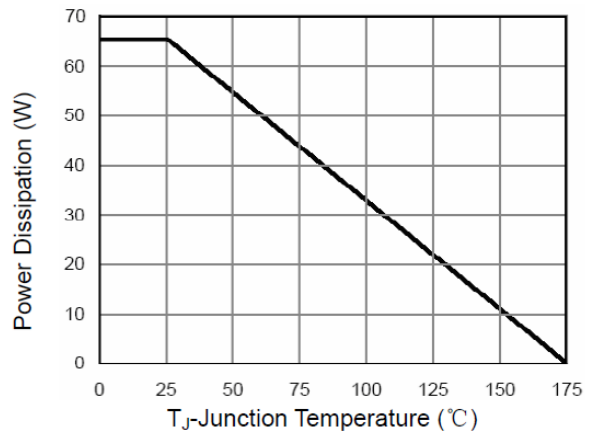

Figure 9 Power De-rating

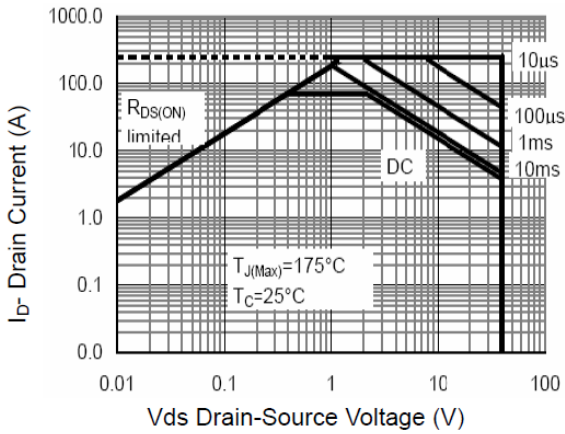

Figure 8 Safe Operation Area

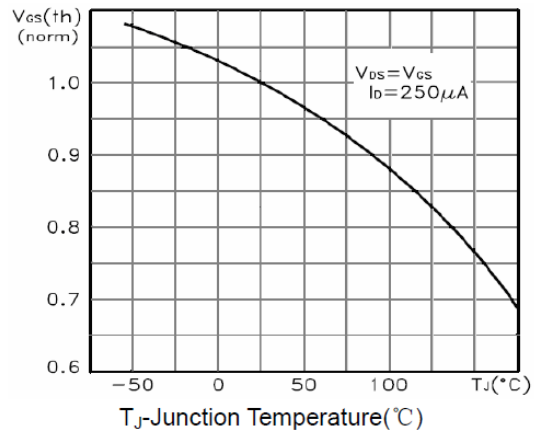

Figure 10 $V_{GS(th)}$ vs Junction Temperature

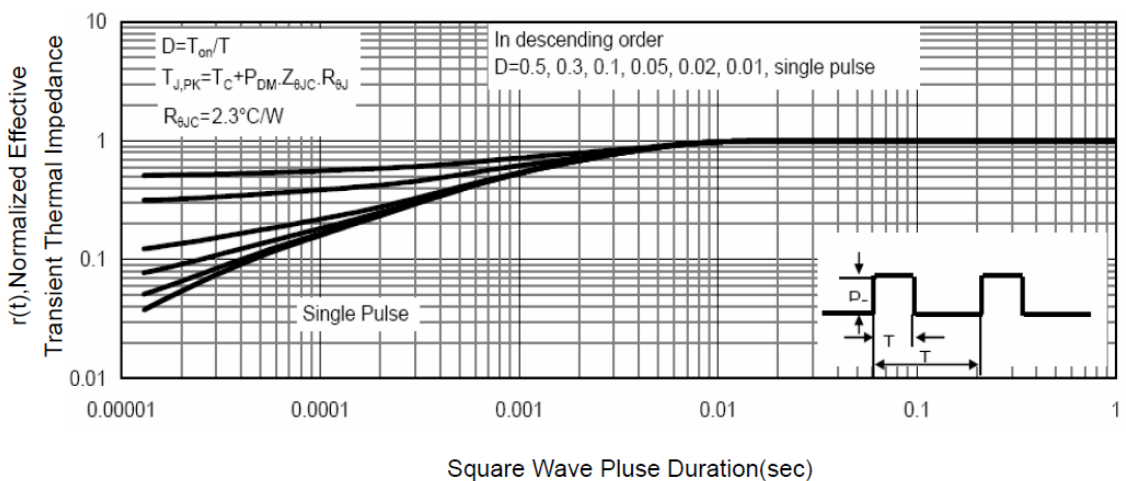
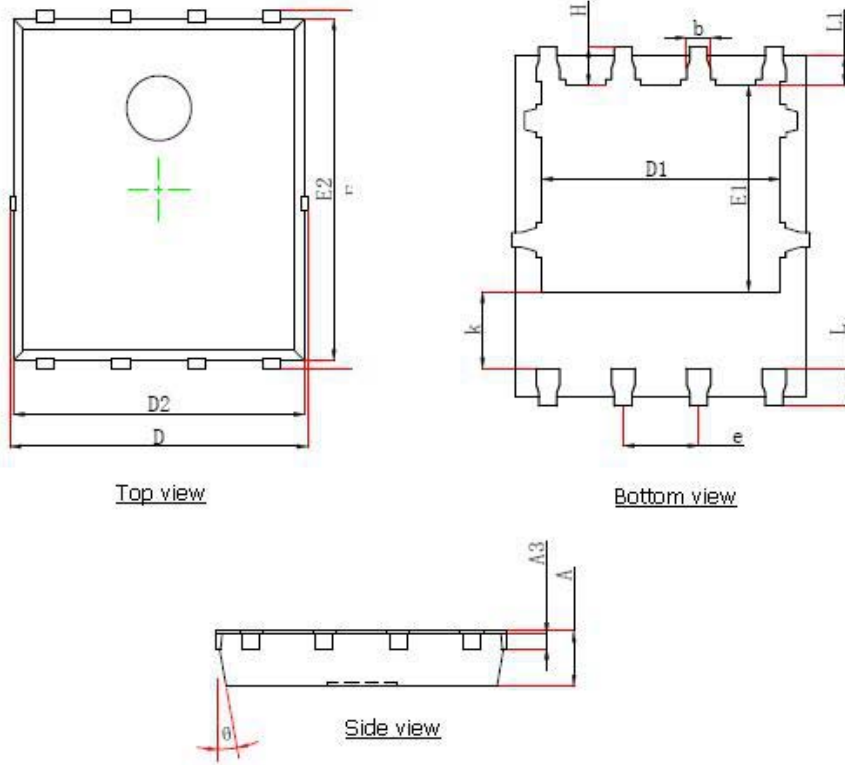

Figure 11 Normalized Maximum Transient Thermal Impedance

SED4060G

Package Outline Dimension

DFN5X6



Symbol	Dimensions In Millimeters		Dimensions In Inches	
	Min.	Max.	Min.	Max.
A	0.900	1.000	0.035	0.039
A3	0.254REF.		0.010REF.	
D	4.944	5.096	0.195	0.201
E	5.974	6.126	0.235	0.241
D1	3.910	4.110	0.154	0.162
E1	3.375	3.575	0.133	0.141
D2	4.824	4.976	0.190	0.196
E2	5.674	5.826	0.223	0.229
k	1.190	1.390	0.047	0.055
b	0.350	0.450	0.014	0.018
e	1.270TYP.		0.050TYP.	
L	0.559	0.711	0.022	0.028
L1	0.424	0.576	0.017	0.023
H	0.574	0.726	0.023	0.029
θ	10°	12°	10°	12°

SED4060G

The SINO-IC logo is a registered trademark of ShangHai Sino-IC Microelectronics Co., Ltd.
© 2005 SINO-IC – Printed in China – All rights reserved.

SHANGHAI SINO-IC MICROELECTRONICS CO., LTD

Add: Building 3, Room 3401-03, No.200 Zhangheng Road, ZhangJiang Hi-Tech Park, Pudong,
Shanghai 201203, China

Phone: +86-21-33932402 33932403 33932405 33933508 33933608

Fax: +86-21-33932401

Email: webmaster@sino-ic.net

Website: <http://www.sino-ic.net>