

DMOS FULL-BRIDGE MOTOR DRIVERS

 Check for Samples: [DRV8800](#), [DRV8801](#)

FEATURES

- Low ON-Resistance [$r_{DS(on)}$] Outputs
- Overcurrent Protection
- Motor Lead Short-to-Supply Protection
- Short-to-Ground Protection
- Low-Power Mode
- Synchronous Rectification
- Diagnostic Output
- Internal Undervoltage Lockout (UVLO)
- Crossover-Current Protection
- 16-Pin QFN With PowerPAD™ Package

APPLICATIONS

- Printers
- Industrial Automation

DESCRIPTION/ORDERING INFORMATION

Designed to control dc motors by using pulse width modulation (PWM), the DRV8800/DRV8801 is capable of peak output currents up to ± 2.8 A and operating voltages up to 36 V.

The PHASE and ENABLE inputs provide dc motor speed and direction control by applying external pulse-width modulation (PWM) and control signals. Internal synchronous rectification control circuitry provides lower power dissipation during PWM operation.

Internal circuit protection includes motor lead short-to-supply/short-to-ground, thermal shutdown with hysteresis, undervoltage monitoring of VBB and VCP, and crossover-current protection.

The DRV8800/DRV8801 is supplied in a thin-profile 16-pin QFN (RTY) PowerPAD™ package, providing enhanced thermal dissipation. The devices are lead free (Pb free).

ORDERING INFORMATION

T _A	PACKAGE ⁽¹⁾ (2)	ORDERABLE PART NUMBER	TOP-SIDE MARKING
-40°C to 85°C	Plastic QFN 16 (S-PQFP-16) – RTY	DRV8800RTYR	DRV8800
		DRV8800RTYT	DRV8800
		DRV8801RTYR	DRV8801
		DRV8801RTYT	DRV8801
	TSSOP - PWP	DRV8800PWP	DRV8800
		DRV8800PWPR	DRV8800
		DRV8801PWP	DRV8801
		DRV8801PWPR	DRV8801

(1) For the most current package and ordering information, see the Package Option Addendum at the end of this document, or see the TI website at www.ti.com.

(2) Package drawings, thermal data, and symbolization are available at www.ti.com/packaging.



Please be aware that an important notice concerning availability, standard warranty, and use in critical applications of Texas Instruments semiconductor products and disclaimers thereto appears at the end of this data sheet.

PowerPAD is a trademark of Texas Instruments Incorporated.

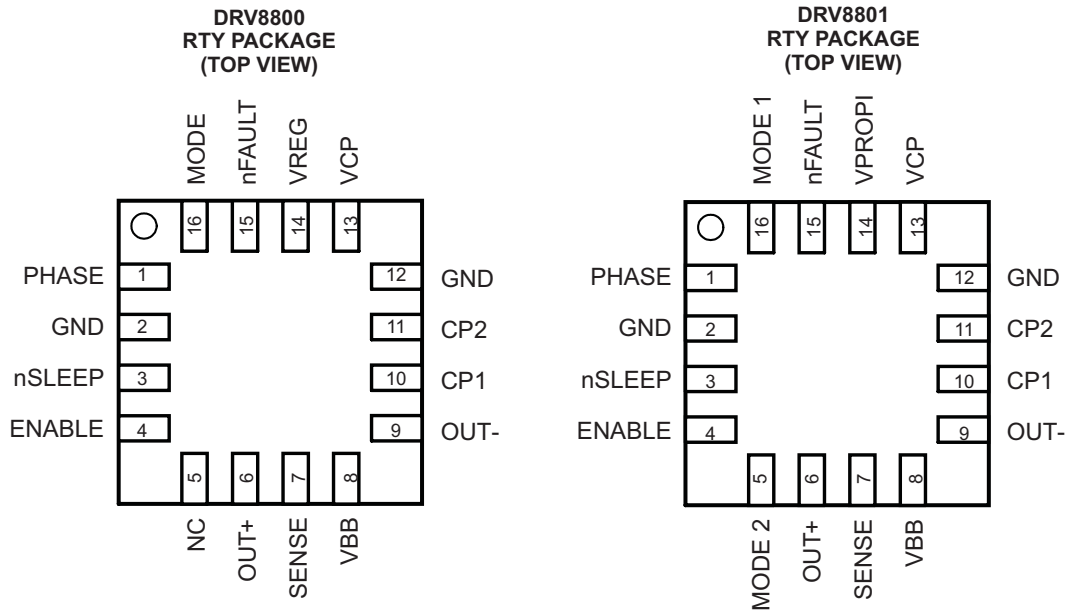

NC – Do not connect

TERMINAL FUNCTIONS

NO.	TERMINAL		DESCRIPTION
	NAME		
	DRV8800	DRV8801	
1	PHASE	PHASE	Phase logic input for direction control
2	GND	GND	Ground
3	nSLEEP	nSLEEP	Sleep logic input
4	ENABLE	ENABLE	Enable logic input
5	NC	MODE 2	No connect (DRV8800), Mode 2 logic input (DRV8801)
6	OUT+	OUT+	DMOS full-bridge output positive
7	SENSE	SENSE	Sense power return
8	VBB	VBB	Load supply voltage
9	OUT-	OUT-	DMOS full-bridge output negative
10	CP1	CP1	Charge-pump capacitor 1
11	CP2	CP2	Charge-pump capacitor 2
12	GND	GND	Ground
13	VCP	VCP	Reservoir capacitor
14	VREG	VPROPI	Regulated voltage (DRV8800), Winding current proportional voltage output (DRV8801)
15	nFAULT	nFAULT	Fault open-drain output
16	MODE	MODE 1	Mode logic input
	Thermal pad	Thermal pad	Exposed pad for thermal dissipation connect to GND pins

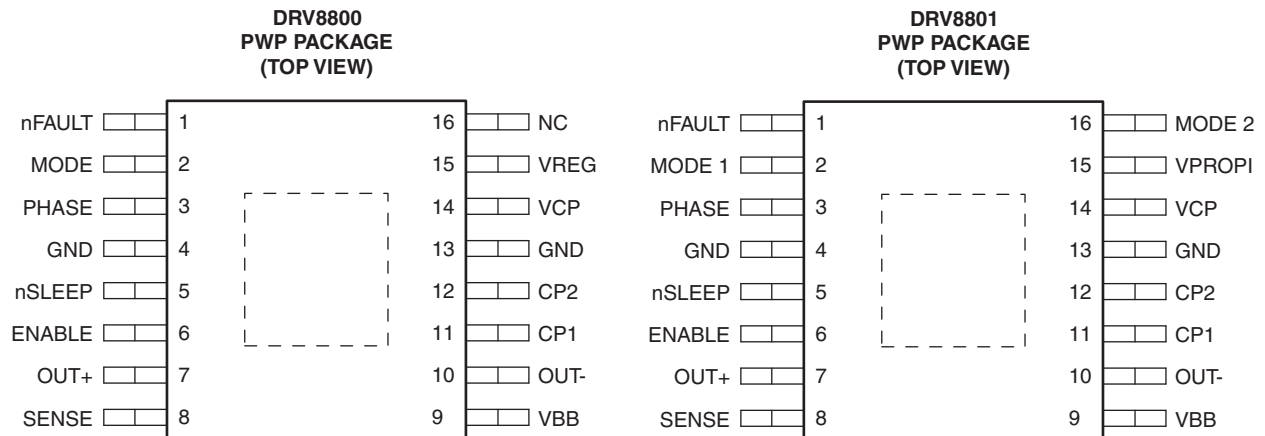

NC – Do not connect

TERMINAL FUNCTIONS

NO.	TERMINAL		DESCRIPTION
	NAME		
	DRV8800	DRV8801	
1	nFAULT	nFAULT	Fault open-drain output
2	MODE	MODE 1	Mode logic input
3	PHASE	PHASE	Logic input for direction control
4	GND	GND	Ground
5	nSLEEP	nSLEEP	Sleep logic input
6	ENABLE	ENABLE	Enable logic input
7	OUT+	OUT+	DMOS full-bridge output positive
8	SENSE	SENSE	Sense power return
9	VBB	VBB	Load supply voltage
10	OUT-	OUT-	DMOS full-bridge output negative
11	CP1	CP1	Charge-pump capacitor 1
12	CP2	CP2	Charge-pump capacitor 2
13	GND	GND	Ground
14	VCP	VCP	Reservoir capacitor
15	VREG	VPROPI	Regulated voltage (DRV8800), Winding current proportional voltage output (DRV8801)
16	NC	MODE 2	No connect (DRV8800), Mode 2 logic input (DRV8801)
	Thermal pad	Thermal pad	Exposed pad for thermal dissipation connect to GND pins

Figure 1. DRV8800 TYPICAL APPLICATION DIAGRAM

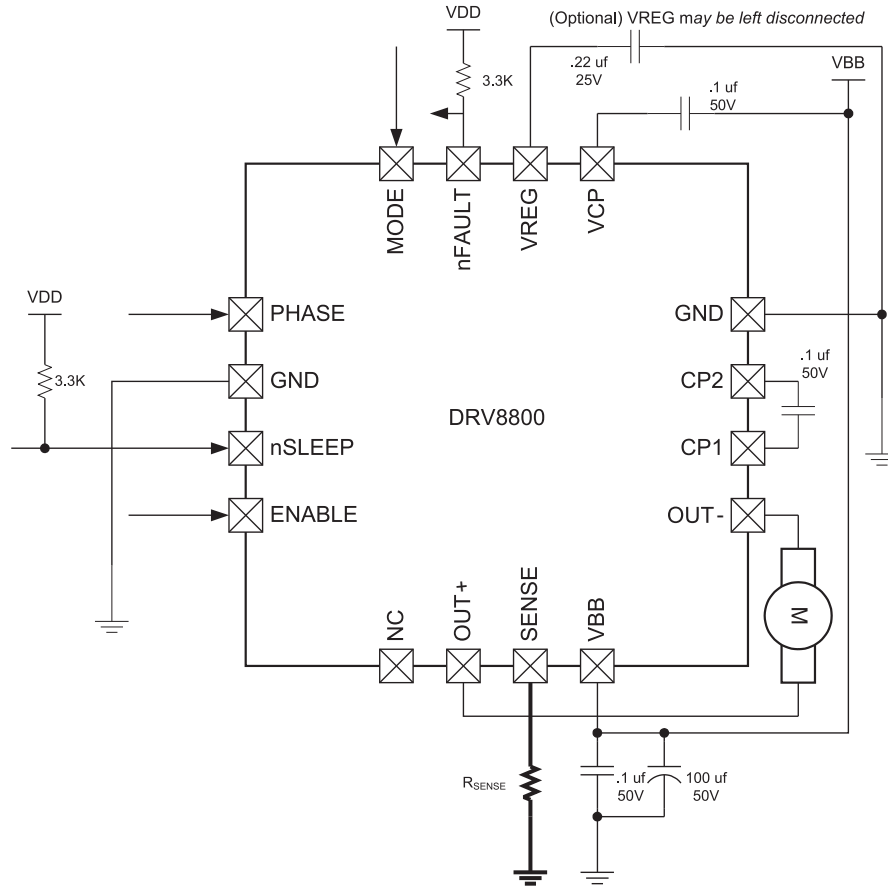

Figure 2. DRV8801 TYPICAL APPLICATION DIAGRAM

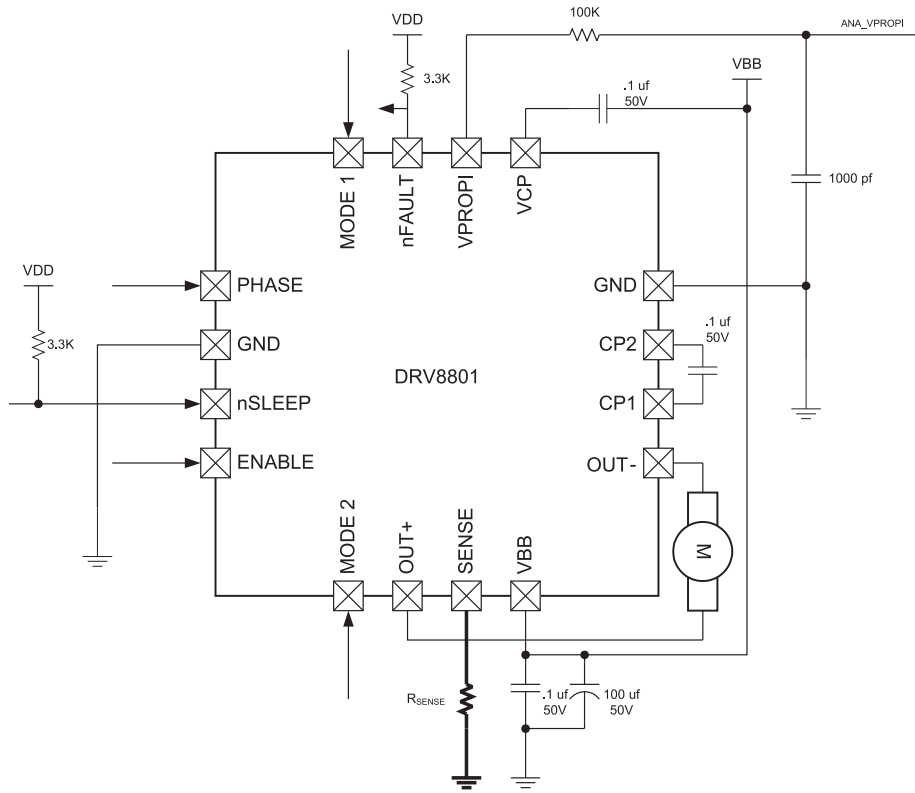

Figure 3. DRV8800 FUNCTIONAL BLOCK DIAGRAM

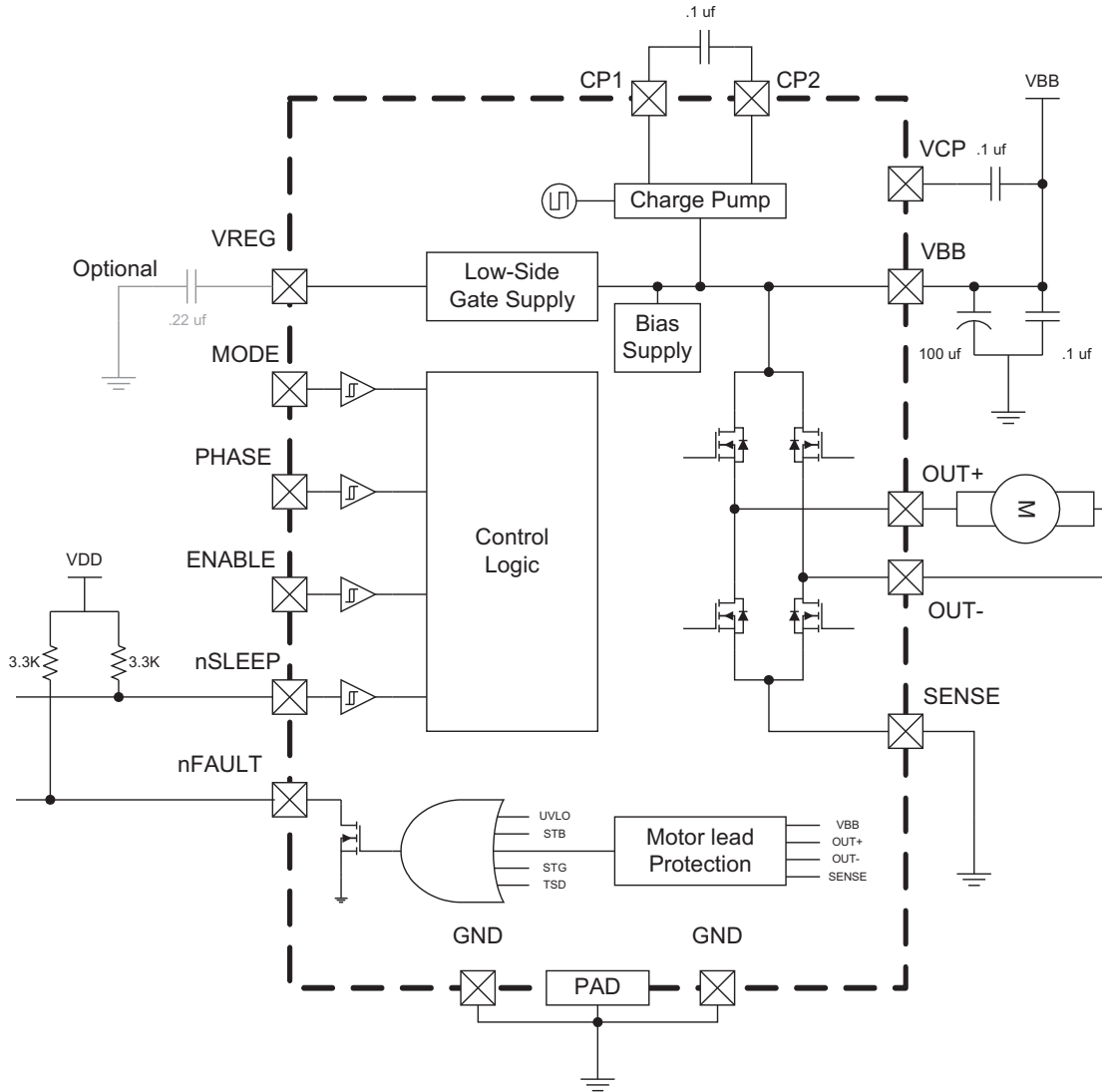
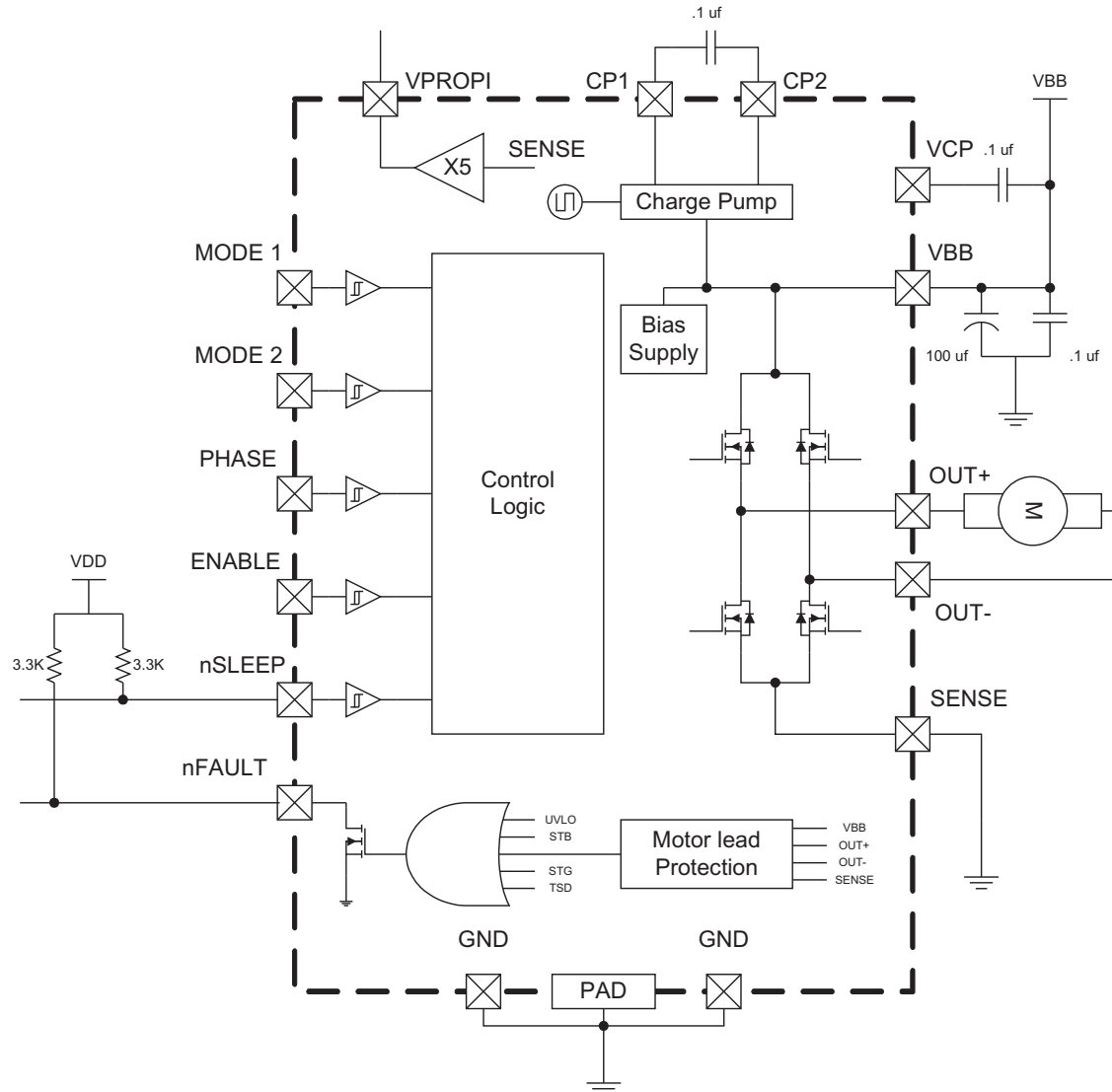

Figure 4. DRV8801 FUNCTIONAL BLOCK DIAGRAM



ABSOLUTE MAXIMUM RATINGS⁽¹⁾

over operating free-air temperature range (unless otherwise noted)

		MIN	MAX	UNIT
VBB	Load supply voltage ⁽²⁾		40	V
	Output current		2.8	A
V _{Sense}	Sense voltage		±500	mV
	VBB to OUTx		36	V
	OUTx to SENSE		36	V
VDD	Logic input voltage ⁽²⁾	-0.3	7	V
ESD rating	Human-Body Model (HBM)		±2	kV
	Charged-Device Model (CDM)		500	V
Continuous total power dissipation		See THERMAL INFORMATION Table		
T _A	Operating free-air temperature range	-40	85	°C
T _J	Maximum junction temperature		150	°C
T _{stg}	Storage temperature range	-40	125	°C

- (1) Stresses beyond those listed under “absolute maximum ratings” may cause permanent damage to the device. These are stress ratings only, and functional operation of the device at these or any other conditions beyond those indicated under “recommended operating conditions” is not implied. Exposure to absolute-maximum-rated conditions for extended periods may affect device reliability.
- (2) All voltage values are with respect to network ground terminal.

THERMAL INFORMATION

THERMAL METRIC		DRV8800/01	DRV8800/01	UNITS
		RTY	PWP	
		16 PINS	16 PINS	
θ _{JA}	Junction-to-ambient thermal resistance ⁽¹⁾	38.1	43.9	°C/W
θ _{JCtop}	Junction-to-case (top) thermal resistance ⁽²⁾	36.7	30.8	
θ _{JB}	Junction-to-board thermal resistance ⁽³⁾	16.1	25.3	
ψ _{JT}	Junction-to-top characterization parameter ⁽⁴⁾	0.3	1.1	
ψ _{JB}	Junction-to-board characterization parameter ⁽⁵⁾	16.2	25	
θ _{JCbot}	Junction-to-case (bottom) thermal resistance ⁽⁶⁾	4.1	5.6	

- (1) The junction-to-ambient thermal resistance under natural convection is obtained in a simulation on a JEDEC-standard, high-K board, as specified in JESD51-7, in an environment described in JESD51-2a.
- (2) The junction-to-case (top) thermal resistance is obtained by simulating a cold plate test on the package top. No specific JEDEC-standard test exists, but a close description can be found in the ANSI SEMI standard G30-88.
- (3) The junction-to-board thermal resistance is obtained by simulating in an environment with a ring cold plate fixture to control the PCB temperature, as described in JESD51-8.
- (4) The junction-to-top characterization parameter, ψ_{JT}, estimates the junction temperature of a device in a real system and is extracted from the simulation data for obtaining θ_{JA}, using a procedure described in JESD51-2a (sections 6 and 7).
- (5) The junction-to-board characterization parameter, ψ_{JB}, estimates the junction temperature of a device in a real system and is extracted from the simulation data for obtaining θ_{JA}, using a procedure described in JESD51-2a (sections 6 and 7).
- (6) The junction-to-case (bottom) thermal resistance is obtained by simulating a cold plate test on the exposed (power) pad. No specific JEDEC standard test exists, but a close description can be found in the ANSI SEMI standard G30-88.

RECOMMENDED OPERATING CONDITIONS

		MIN	NOM	MAX	UNIT
V _{IN}	Input voltage, VBB	8	32	38	V
T _A	Operating free-air temperature	-40		85	°C

ELECTRICAL CHARACTERISTICS

over recommended operating conditions (unless otherwise noted)

PARAMETER		TEST CONDITIONS	MIN	TYP	MAX	UNIT
IBB	Motor supply current	$f_{PWM} < 50 \text{ kHz}$	6			mA
		Charge pump on, Outputs disabled	3.2			
		Sleep mode	10			μA
V_{IH}	PHASE, ENABLE, MODE input voltage		2			V
V_{IL}			0.8			
V_{IH}	nSLEEP input voltage		2.7			V
V_{IL}			0.8			
I_{IH}	PHASE, MODE input current	$V_{IN} = 2 \text{ V}$	<1.0		20	μA
I_{IL}		$V_{IN} = 0.8 \text{ V}$	-20	≤ -2.0	20	
I_{IH}	ENABLE input current	$V_{IN} = 2 \text{ V}$	40		100	μA
I_{IL}		$V_{IN} = 0.8 \text{ V}$	16		40	
I_{IH}	nSLEEP input current	$V_{IN} = 2.7 \text{ V}$	27		50	μA
I_{IL}		$V_{IN} = 0.8 \text{ V}$	<1		10	
V_{OL}	nFAULT output voltage	$I_{sink} = 1 \text{ mA}$	0.4			V
VBBNFR	VBB nFAULT release	$8 \text{ V} < V_{BB} < 40 \text{ V}$	12		13.8	V
V_{IHys}	Input hysteresis, except nSLEEP		100	500	800	mV
$r_{DS(on)}$	Output ON resistance	Source driver, $I_{OUT} = -2.8 \text{ A}$, $T_J = 25^\circ\text{C}$	0.48		Ω	
		Source driver, $I_{OUT} = -2.8 \text{ A}$, $T_J = 125^\circ\text{C}$	0.74	0.85		
		Sink driver, $I_{OUT} = 2.8 \text{ A}$, $T_J = 25^\circ\text{C}$	0.35			
		Sink driver, $I_{OUT} = 2.8 \text{ A}$, $T_J = 125^\circ\text{C}$	0.52	0.7		
VTRP	RSENSE voltage trip	SENSE connected to ground through a 0.2- Ω resistor	500		mV	
V_f	Body diode forward voltage	Source diode, $I_f = -2.8 \text{ A}$	1.4			V
		Sink diode, $I_f = 2.8 \text{ A}$	1.4			
t_{pd}	Propagation delay time	PWM, Change to source or sink ON	600			ns
		PWM, Change to source or sink OFF	100			
t_{COD}	Crossover delay		500			ns
DAGain	Differential AMP gain	Sense = 0.1 V to 0.4 V	5			V/V
Protection Circuitry						
VUV	UVLO threshold	VBB increasing	6.5		7.5	V
I_{OCP}	Overcurrent threshold		3			A
t_{DEG}	Overcurrent deglitch time		3			μs
t_{OCP}	Overcurrent retry time		1.2			ms
TJW	Thermal warning temperature	Temperature increasing ⁽¹⁾	160			$^\circ\text{C}$
TJTSD	Thermal shutdown temperature	Temperature increasing ⁽²⁾	175			$^\circ\text{C}$

- (1) Once the device reaches the thermal warning temperature of 160°C, the device will remain in thermal warning until the device cools to 145°C. This is known as the device's thermal warning hysteresis.
- (2) Once the device reaches the thermal shutdown temperature of 175°C, the device will remain in thermal shutdown until the device cools to 160°C. This is known as the device's thermal shutdown hysteresis.

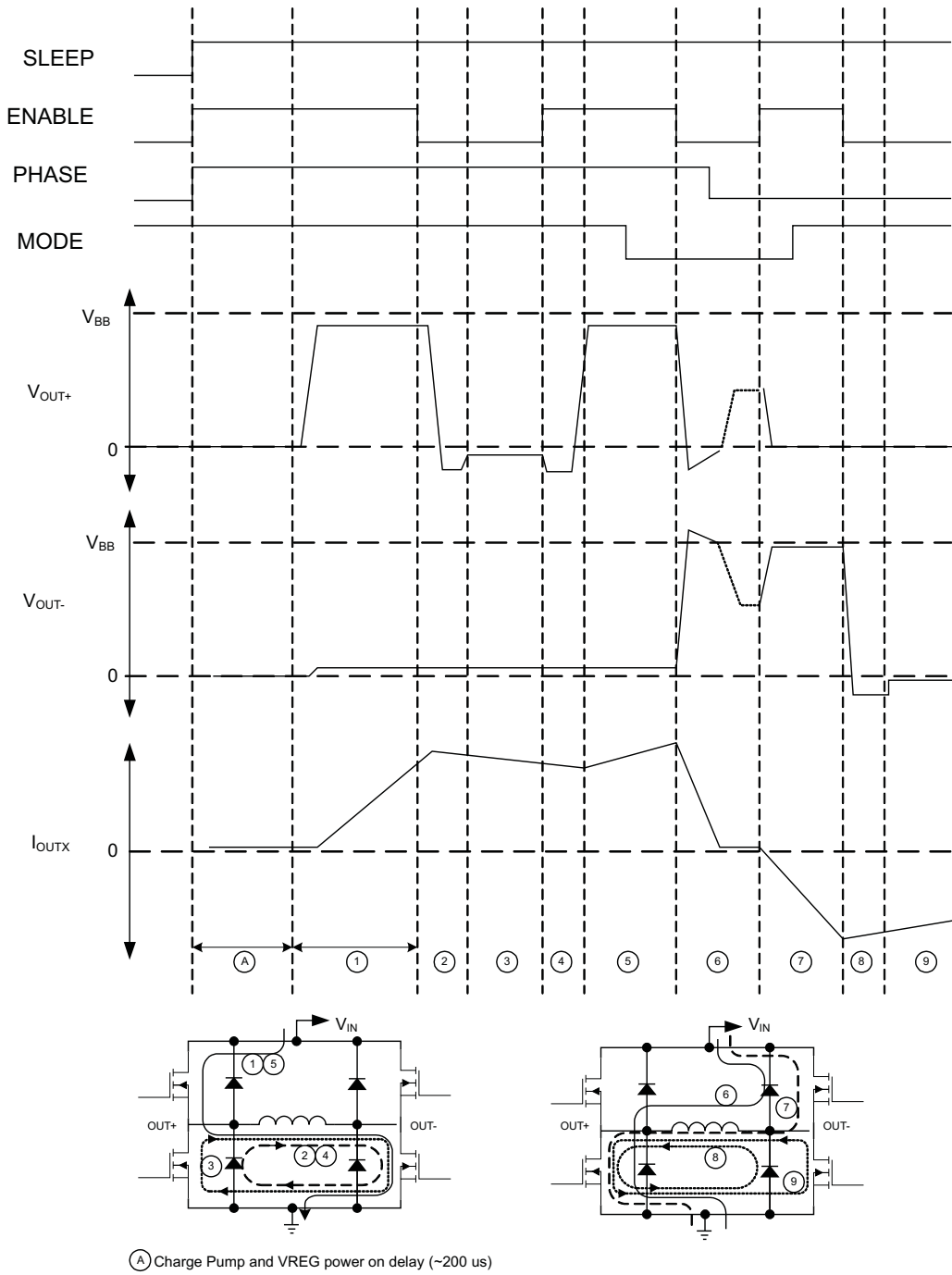

Figure 5. PWM Control Timing

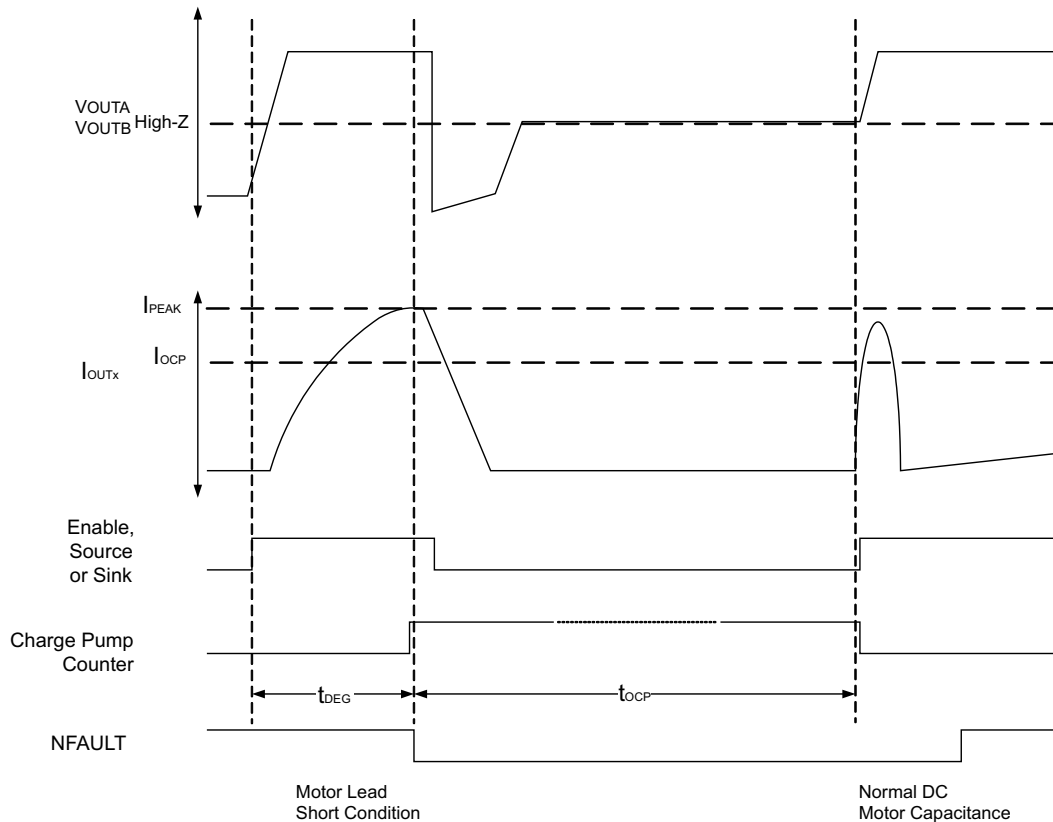

Figure 6. Overcurrent Control Timing

FUNCTIONAL DESCRIPTION

Device Operation

The DRV8800/DRV8801 is designed to drive one dc motor. The current through the output full-bridge switches and all N-channel DMOS are regulated with a fixed off-time PWM control circuit.

Logic Inputs

It is recommended to use a high-value pullup resistor when logic inputs are pulled up to V_{DD} . This resistor limits the current to the input in case an overvoltage event occurs. Logic inputs are nSLEEP, MODE, PHASE, and ENABLE. Voltages higher than 7 V on any logic input can cause damage to the input structure.

VREG (DRV8800 Only)

This output represents a measurement of the internal regulator voltage. This pin should be left disconnected. A voltage of approximately 7.5 V can be measured at this pin.

VPROPI (DRV8801 Only)

This output offers an analog voltage proportional to the winding current. Voltage at this terminal is five times greater than the motor winding current ($V_{PROPI} = 5 \times I$). VPROPI is meaningful only if there is a resistor connected to the SENSE pin. If SENSE is connected to ground, VPROPI measures 0 V. During slow decay, VPROPI outputs 0 V. VPROPI can output a maximum of 2.5 V, since at 500 mV on SENSE, the H-bridge is disabled.

Charge Pump

The charge pump is used to generate a supply above VBB to drive the source-side DMOS gates. A 0.1- μ F ceramic monolithic capacitor should be connected between CP1 and CP2 for pumping purposes. A 0.1- μ F ceramic monolithic capacitor, CStorage, should be connected between VCP and VBB to act as a reservoir to run the high-side DMOS devices. The VCP voltage level is internally monitored and, in the case of a fault condition, the outputs of the device are disabled.

Shutdown

As a measure to protect the device, faults caused by very high junction temperatures or low voltage on VCP disable the outputs of the device until the fault condition is removed. At power on, the UVLO circuit disables the drivers.

Low-Power Mode

Control input nSLEEP is used to minimize power consumption when the DRV8800/DRV8801 is not in use. This disables much of the internal circuitry, including the internal voltage rails and charge pump. nSLEEP is asserted low. A logic high on this input pin results in normal operation. When switching from low to high, the user should allow a 1-ms delay before applying PWM signals. This time is needed for the charge pump to stabilize.

- **MODE 1 (MODE on the DRV8800)**
Input MODE 1 is used to toggle between fast-decay mode and slow-decay mode. A logic high puts the device in slow-decay mode.
- **MODE 2 (DRV8801 only)**
MODE 2 is used to select which set of drivers (high side versus low side) is used during the slow-decay recirculation. MODE 2 is meaningful only when MODE 1 is asserted high. A logic high on MODE 2 has current recirculation through the high-side drivers. A logic low has current recirculation through the low-side drivers.

Braking

The braking function is implemented by driving the device in slow-decay mode (MODE 1 pin is high) and deasserting the enable to low. Because it is possible to drive current in both directions through the DMOS switches, this configuration effectively shorts out the motor-generated BEMF as long as the ENABLE chop mode is asserted. The maximum current can be approximated by V_{BEMF}/R_L . Care should be taken to ensure that the maximum ratings of the device are not exceeded in worse-case braking situations – high-speed and high-inertia loads.

Diagnostic Output

The nFAULT pin signals a problem with the chip via an open-drain output. A motor fault, undervoltage condition, or $T_J > 160^\circ\text{C}$ drives the pin low. This output is not valid when nSLEEP puts the device into minimum power dissipation mode (i.e., nSLEEP is low). nFAULT stays asserted (nFAULT = L) until VBB reaches VBBNFR to give the charge pump headroom to reach its undervoltage threshold. nFAULT is a status-only signal and does not affect any device functionality. The H-bridge portion still operates normally down to $V_{BB} = 8\text{ V}$ with nFAULT asserted.

Thermal Shutdown (TSD)

Two die-temperature monitors are integrated on the chip. As die temperature increases toward the maximum, a thermal warning signal is triggered at 160°C . This fault drives the nFAULT low, but does not disable the operation of the chip. If the die temperature increases further, to approximately 175°C , the full-bridge outputs are disabled until the internal temperature falls below a hysteresis of 15°C .

Control Logic Table⁽¹⁾

PINS							OPERATION
PHASE	ENABLE	MODE 1	MODE 2	nSLEEP	OUT+	OUT-	
1	1	X	X	1	H	L	Forward
0	1	X	X	1	L	H	Reverse
X	0	1	0	1	L	L	Brake (slow decay)
X	0	1	1	1	H	H	Brake (slow decay)
1	0	0	X	1	L	H	Fast-decay synchronous rectification ⁽²⁾
0	0	0	X	1	H	L	Fast-decay synchronous rectification ⁽²⁾
X	X	X	X	0	Z	Z	Sleep mode

(1) X = Don't care, Z = high impedance

(2) To prevent reversal of current during fast-decay synchronous rectification, outputs go to the high-impedance state as the current approaches 0 A.

Overcurrent Protection

The current flowing through the high-side and low-side drivers is monitored to ensure that the motor lead is not shorted to supply or ground. If a short is detected, the full-bridge outputs are turned off, flag nFAULT is driven low, and a 1.2-ms fault timer is started. After this 1.2-ms period, t_{OCP} , the device is then allowed to follow the input commands and another turnon is attempted (nFAULT becomes high again during this attempt). If there is still a fault condition, the cycle repeats. If after t_{OCP} expires it is determined the short condition is not present, normal operation resumes and nFAULT is deasserted.

APPLICATION INFORMATION

Power Dissipation

First-order approximation of power dissipation in the DRV8800/DRV8801 can be calculated by examining the power dissipation in the full-bridge during each of the operation modes. DRV8800/DRV8801 utilize synchronous rectification. During the decay cycle, the body diode is shorted by the low- $r_{DS(on)}$ driver, which in turn reduces power dissipation in the full-bridge. In order to prevent shoot through (high-side and low-side drivers on the same side are ON at the same time), DRV8800/DRV8801 implement a 500-ns typical crossover delay time. During this period, the body diode in the decay current path conducts the current until the DMOS driver turns on. High current and high ambient temperature applications should take this into consideration. In addition, motor parameters and switching losses can add power dissipation that could affect critical applications.

Drive Current

This current path is through the high-side sourcing DMOS driver, motor winding, and low-side sinking DMOS driver. Power dissipation I^2R losses in one source and one sink DMOS driver, as shown in Equation 1.

$$P_D = I^2 (r_{DS(on)Source} + r_{DS(on)Sink}) \quad (1)$$

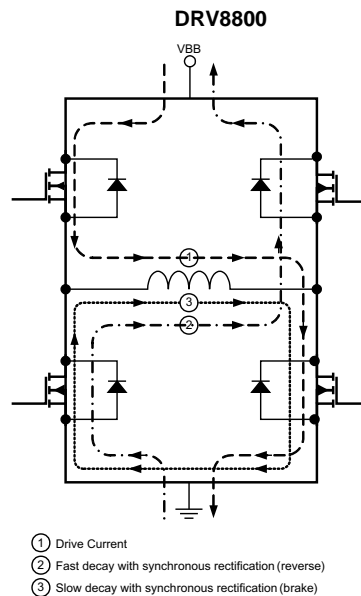

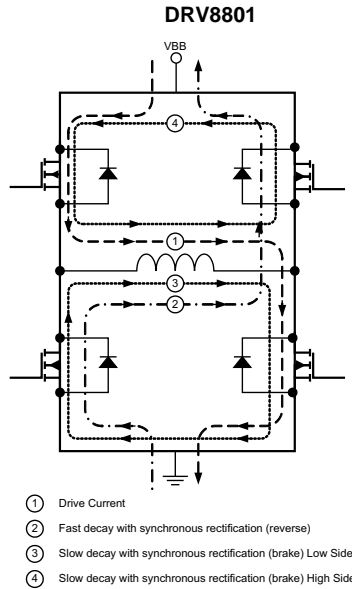

Figure 7. Current Path

Fast Decay With Synchronous Rectification

This decay mode is equivalent to a phase change where the opposite drivers are switched on. When in fast decay, the motor current is not allowed to go negative (direction change). Instead, as the current approaches zero, the drivers turn off. The power calculation is the same as the drive current calculation (see [Equation 1](#)).

Slow-Decay SR (Brake Mode)

In slow-decay mode, both low-side sinking drivers turn on, allowing the current to circulate through the H-bridge's low side (two sink drivers) and the load. Power dissipation I^2R losses in the two sink DMOS drivers:

$$P_D = I^2 (2 \cdot r_{DS(on)Sink}) \quad (2)$$

SENSE

A low-value resistor can be placed between the SENSE pin and ground for current-sensing purposes. To minimize ground-trace IR drops in sensing the output current level, the current-sensing resistor should have an independent ground return to the star ground point. This trace should be as short as possible. For low-value sense resistors, the IR drops in the PCB can be significant, and should be taken into account.

NOTE

When selecting a value for the sense resistor, SENSE does not exceed the maximum voltage of ± 500 mV. The H-bridge is disabled and enters recirculation when any current in the motor windings generates a SENSE voltage greater than or equal to 500 mV.

Ground

A ground power plane should be located as close to the DRV8800/DRV8801 as possible. The copper ground plane directly under the thermal pad makes a good location. This pad can then be connected to ground for this purpose.

Layout

The printed circuit board (PCB) should use a heavy ground plane. For optimum electrical and thermal performance, the DRV8800/DRV8801 must be soldered directly onto the board. On the underside of the DRV8800/DRV8801 is a thermal pad, which provides a path for enhanced thermal dissipation. The thermal pad should be soldered directly to an exposed surface on the PCB. Thermal vias are used to transfer heat to other layers of the PCB. For more information on this technique, please refer to document SLMA002.

The load supply pin, VBB, should be decoupled with an electrolytic capacitor (typically 100 μ F) in parallel with a ceramic capacitor placed as close as possible to the device. The ceramic capacitors between VCP and VBB, connected to VREG, and between CP1 and CP2 should be as close to the pins of the device as possible, in order to minimize lead inductance.

REVISION HISTORY

Changes from Revision H (November 2013) to Revision I	Page
• Added I_{OCP} to ELECTRICAL CHARACTERISTICS	9
• Changed Figure 6	11

Changes from Revision G (October 2013) to Revision H	Page
• Changed maximum junction temperature from 190°C to 150°C	8
• Changed VTRP description/test conditions	9
• Changed Protection Circuitry section	9
• Changed Note in SENSE section	16

PACKAGING INFORMATION

Orderable Device	Status (1)	Package Type	Package Drawing	Pins	Package Qty	Eco Plan (2)	Lead/Ball Finish (6)	MSL Peak Temp (3)	Op Temp (°C)	Device Marking (4/5)	Samples
DRV8800PWP	ACTIVE	HTSSOP	PWP	16	90	Green (RoHS & no Sb/Br)	CU NIPDAU	Level-2-260C-1 YEAR	-40 to 85	DRV8800	Samples
DRV8800PWPR	ACTIVE	HTSSOP	PWP	16	2000	Green (RoHS & no Sb/Br)	CU NIPDAU	Level-2-260C-1 YEAR	-40 to 85	DRV8800	Samples
DRV8800RTYR	ACTIVE	QFN	RTY	16	3000	Green (RoHS & no Sb/Br)	CU NIPDAU	Level-3-260C-168 HR	-40 to 85	DRV 8800	Samples
DRV8800RTYT	ACTIVE	QFN	RTY	16	250	Green (RoHS & no Sb/Br)	CU NIPDAU	Level-3-260C-168 HR	-40 to 85	DRV 8800	Samples
DRV8801PWP	ACTIVE	HTSSOP	PWP	16	90	Green (RoHS & no Sb/Br)	CU NIPDAU	Level-2-260C-1 YEAR	-40 to 85	DRV8801	Samples
DRV8801PWPR	ACTIVE	HTSSOP	PWP	16	2000	Green (RoHS & no Sb/Br)	CU NIPDAU	Level-2-260C-1 YEAR	-40 to 85	DRV8801	Samples
DRV8801RTYR	ACTIVE	QFN	RTY	16	3000	Green (RoHS & no Sb/Br)	CU NIPDAU	Level-3-260C-168 HR	-40 to 85	DRV 8801	Samples
DRV8801RTYT	ACTIVE	QFN	RTY	16	250	Green (RoHS & no Sb/Br)	CU NIPDAU	Level-3-260C-168 HR	-40 to 85	DRV 8801	Samples

(1) The marketing status values are defined as follows:

ACTIVE: Product device recommended for new designs.

LIFEBUY: TI has announced that the device will be discontinued, and a lifetime-buy period is in effect.

NRND: Not recommended for new designs. Device is in production to support existing customers, but TI does not recommend using this part in a new design.

PREVIEW: Device has been announced but is not in production. Samples may or may not be available.

OBsolete: TI has discontinued the production of the device.

(2) Eco Plan - The planned eco-friendly classification: Pb-Free (RoHS), Pb-Free (RoHS Exempt), or Green (RoHS & no Sb/Br) - please check <http://www.ti.com/productcontent> for the latest availability information and additional product content details.

TBD: The Pb-Free/Green conversion plan has not been defined.

Pb-Free (RoHS): TI's terms "Lead-Free" or "Pb-Free" mean semiconductor products that are compatible with the current RoHS requirements for all 6 substances, including the requirement that lead not exceed 0.1% by weight in homogeneous materials. Where designed to be soldered at high temperatures, TI Pb-Free products are suitable for use in specified lead-free processes.

Pb-Free (RoHS Exempt): This component has a RoHS exemption for either 1) lead-based flip-chip solder bumps used between the die and package, or 2) lead-based die adhesive used between the die and leadframe. The component is otherwise considered Pb-Free (RoHS compatible) as defined above.

Green (RoHS & no Sb/Br): TI defines "Green" to mean Pb-Free (RoHS compatible), and free of Bromine (Br) and Antimony (Sb) based flame retardants (Br or Sb do not exceed 0.1% by weight in homogeneous material)

(3) MSL, Peak Temp. - The Moisture Sensitivity Level rating according to the JEDEC industry standard classifications, and peak solder temperature.

(4) There may be additional marking, which relates to the logo, the lot trace code information, or the environmental category on the device.

(5) Multiple Device Markings will be inside parentheses. Only one Device Marking contained in parentheses and separated by a "~" will appear on a device. If a line is indented then it is a continuation of the previous line and the two combined represent the entire Device Marking for that device.

(6) Lead/Ball Finish - Orderable Devices may have multiple material finish options. Finish options are separated by a vertical ruled line. Lead/Ball Finish values may wrap to two lines if the finish value exceeds the maximum column width.

Important Information and Disclaimer:The information provided on this page represents TI's knowledge and belief as of the date that it is provided. TI bases its knowledge and belief on information provided by third parties, and makes no representation or warranty as to the accuracy of such information. Efforts are underway to better integrate information from third parties. TI has taken and continues to take reasonable steps to provide representative and accurate information but may not have conducted destructive testing or chemical analysis on incoming materials and chemicals. TI and TI suppliers consider certain information to be proprietary, and thus CAS numbers and other limited information may not be available for release.

In no event shall TI's liability arising out of such information exceed the total purchase price of the TI part(s) at issue in this document sold by TI to Customer on an annual basis.

OTHER QUALIFIED VERSIONS OF DRV8801 :

- Automotive: [DRV8801-Q1](#)

NOTE: Qualified Version Definitions:

- Automotive - Q100 devices qualified for high-reliability automotive applications targeting zero defects

TAPE AND REEL INFORMATION

QUADRANT ASSIGNMENTS FOR PIN 1 ORIENTATION IN TAPE

*All dimensions are nominal

Device	Package Type	Package Drawing	Pins	SPQ	Reel Diameter (mm)	Reel Width W1 (mm)	A0 (mm)	B0 (mm)	K0 (mm)	P1 (mm)	W (mm)	Pin1 Quadrant
DRV8800PWPR	HTSSOP	PWP	16	2000	330.0	12.4	6.9	5.6	1.6	8.0	12.0	Q1
DRV8800RTYT	QFN	RTY	16	250	180.0	12.4	4.25	4.25	1.15	8.0	12.0	Q2
DRV8801PWPR	HTSSOP	PWP	16	2000	330.0	12.4	6.9	5.6	1.6	8.0	12.0	Q1
DRV8801RTYT	QFN	RTY	16	250	180.0	12.4	4.25	4.25	1.15	8.0	12.0	Q2

TAPE AND REEL BOX DIMENSIONS

*All dimensions are nominal

Device	Package Type	Package Drawing	Pins	SPQ	Length (mm)	Width (mm)	Height (mm)
DRV8800PWPR	HTSSOP	PWP	16	2000	367.0	367.0	35.0
DRV8800RTYT	QFN	RTY	16	250	210.0	185.0	35.0
DRV8801PWPR	HTSSOP	PWP	16	2000	367.0	367.0	35.0
DRV8801RTYT	QFN	RTY	16	250	210.0	185.0	35.0

PWP (R-PDSO-G16)

PowerPAD™ PLASTIC SMALL OUTLINE

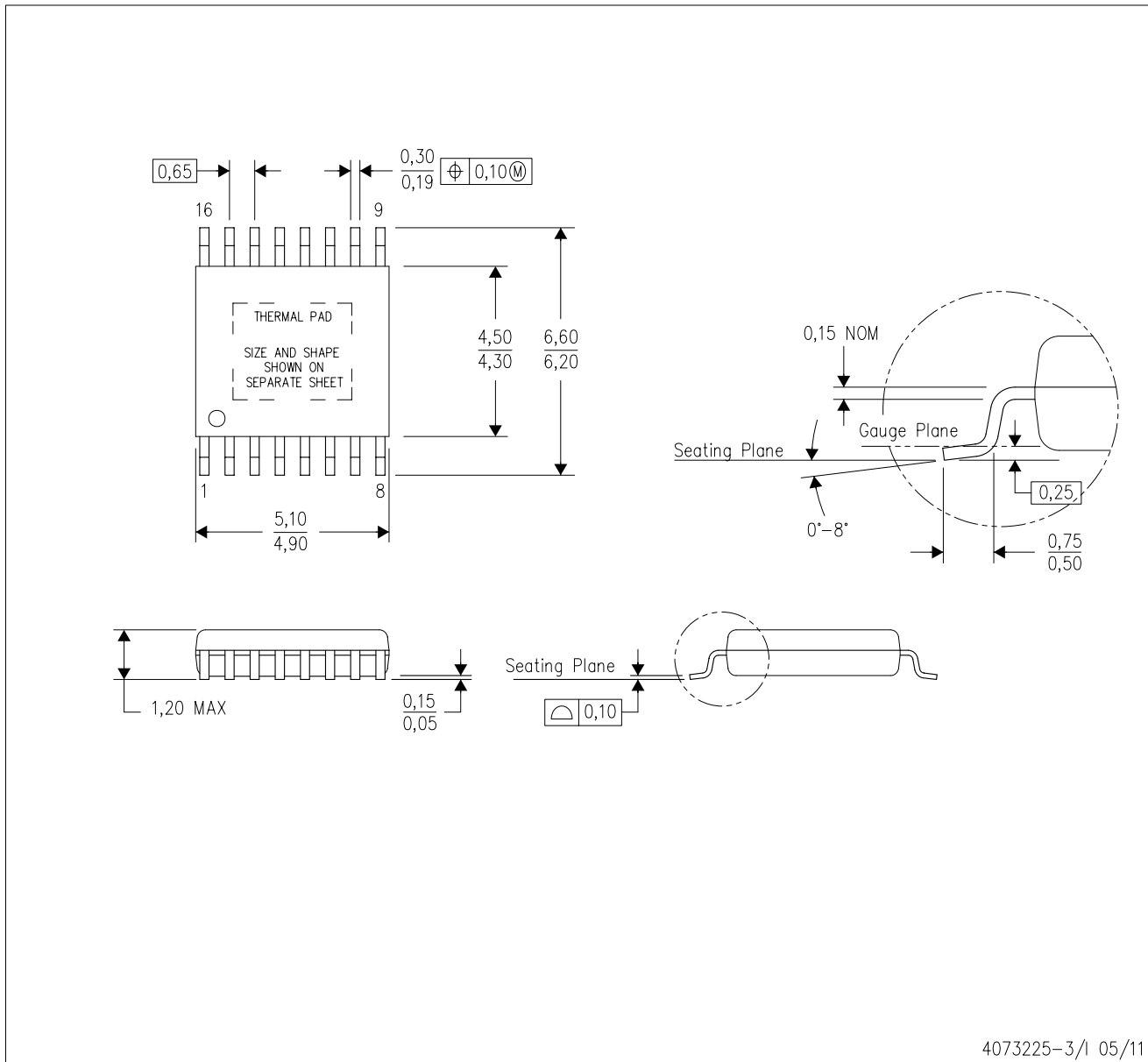

- NOTES:
- A. All linear dimensions are in millimeters.
 - B. This drawing is subject to change without notice.
 - C. Body dimensions do not include mold flash or protrusions. Mold flash and protrusion shall not exceed 0.15 per side.
 - D. This package is designed to be soldered to a thermal pad on the board. Refer to Technical Brief, PowerPad Thermally Enhanced Package, Texas Instruments Literature No. SLMA002 for information regarding recommended board layout. This document is available at www.ti.com <<http://www.ti.com>>.
 - E. See the additional figure in the Product Data Sheet for details regarding the exposed thermal pad features and dimensions.
 - E. Falls within JEDEC MO-153

PowerPAD is a trademark of Texas Instruments.

THERMAL PAD MECHANICAL DATA

PWP (R-PDSO-G16) PowerPAD™ SMALL PLASTIC OUTLINE

THERMAL INFORMATION

This PowerPAD™ package incorporates an exposed thermal pad that is designed to be attached to a printed circuit board (PCB). The thermal pad must be soldered directly to the PCB. After soldering, the PCB can be used as a heatsink. In addition, through the use of thermal vias, the thermal pad can be attached directly to the appropriate copper plane shown in the electrical schematic for the device, or alternatively, can be attached to a special heatsink structure designed into the PCB. This design optimizes the heat transfer from the integrated circuit (IC).

For additional information on the PowerPAD package and how to take advantage of its heat dissipating abilities, refer to Technical Brief, PowerPAD Thermally Enhanced Package, Texas Instruments Literature No. SLMA002 and Application Brief, PowerPAD Made Easy, Texas Instruments Literature No. SLMA004. Both documents are available at www.ti.com.

The exposed thermal pad dimensions for this package are shown in the following illustration.

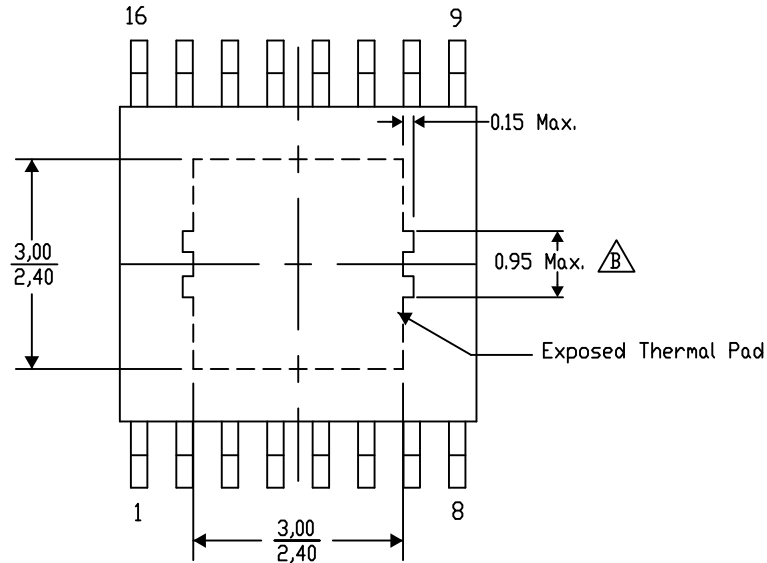

Top View

Exposed Thermal Pad Dimensions

4206332-8/AH 11/13

NOTE: A. All linear dimensions are in millimeters

 Exposed tie strap features may not be present.

PowerPAD is a trademark of Texas Instruments

PWP (R-PDSO-G16)

PowerPAD™ PLASTIC SMALL OUTLINE

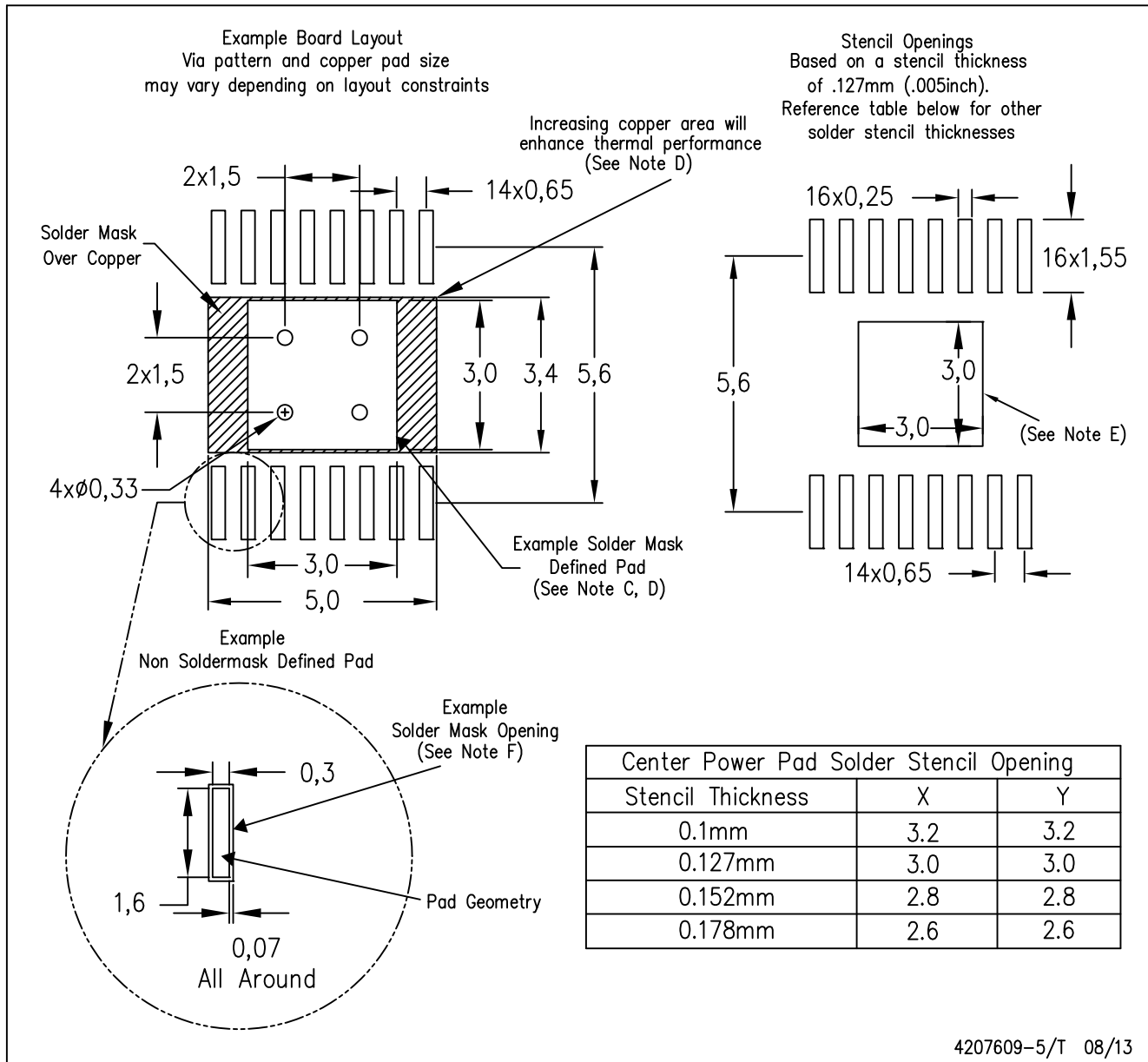

- NOTES:
- A. All linear dimensions are in millimeters.
 - B. This drawing is subject to change without notice.
 - C. Customers should place a note on the circuit board fabrication drawing not to alter the center solder mask defined pad.
 - D. This package is designed to be soldered to a thermal pad on the board. Refer to Technical Brief, PowerPad Thermally Enhanced Package, Texas Instruments Literature No. SLMA002, SLMA004, and also the Product Data Sheets for specific thermal information, via requirements, and recommended board layout. These documents are available at www.ti.com <<http://www.ti.com>>. Publication IPC-7351 is recommended for alternate designs.
 - E. Laser cutting apertures with trapezoidal walls and also rounding corners will offer better paste release. Customers should contact their board assembly site for stencil design recommendations. Example stencil design based on a 50% volumetric metal load solder paste. Refer to IPC-7525 for other stencil recommendations.
 - F. Customers should contact their board fabrication site for solder mask tolerances between and around signal pads.

RTY (S-PWQFN-N16)

PLASTIC QUAD FLATPACK NO-LEAD

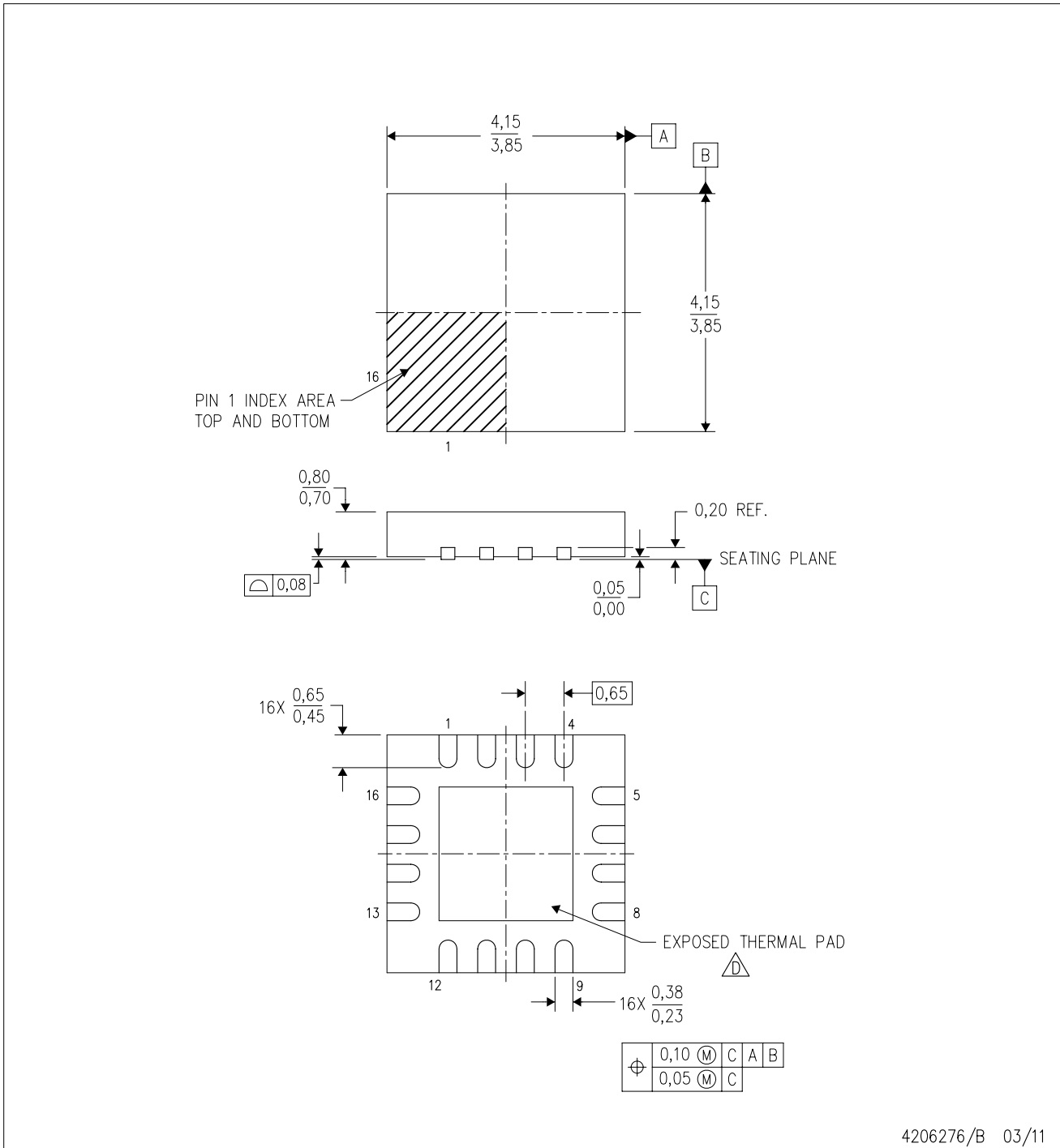

4206276/B 03/11

- NOTES:
- A. All linear dimensions are in millimeters. Dimensioning and tolerancing per ASME Y14.5-1994.
 - B. This drawing is subject to change without notice.
 - C. Quad Flatpack, No-leads (QFN) package configuration.
 - D. The package thermal pad must be soldered to the board for thermal and mechanical performance. See the Product Data Sheet for details regarding the exposed thermal pad dimensions.
 - E. Falls within JEDEC MO-220.

THERMAL PAD MECHANICAL DATA

RTY (S-PWQFN-N16)

PLASTIC QUAD FLATPACK NO-LEAD

THERMAL INFORMATION

This package incorporates an exposed thermal pad that is designed to be attached directly to an external heatsink. The thermal pad must be soldered directly to the printed circuit board (PCB). After soldering, the PCB can be used as a heatsink. In addition, through the use of thermal vias, the thermal pad can be attached directly to the appropriate copper plane shown in the electrical schematic for the device, or alternatively, can be attached to a special heatsink structure designed into the PCB. This design optimizes the heat transfer from the integrated circuit (IC).

For information on the Quad Flatpack No-Lead (QFN) package and its advantages, refer to Application Report, QFN/SON PCB Attachment, Texas Instruments Literature No. SLUA271. This document is available at www.ti.com.

The exposed thermal pad dimensions for this package are shown in the following illustration.

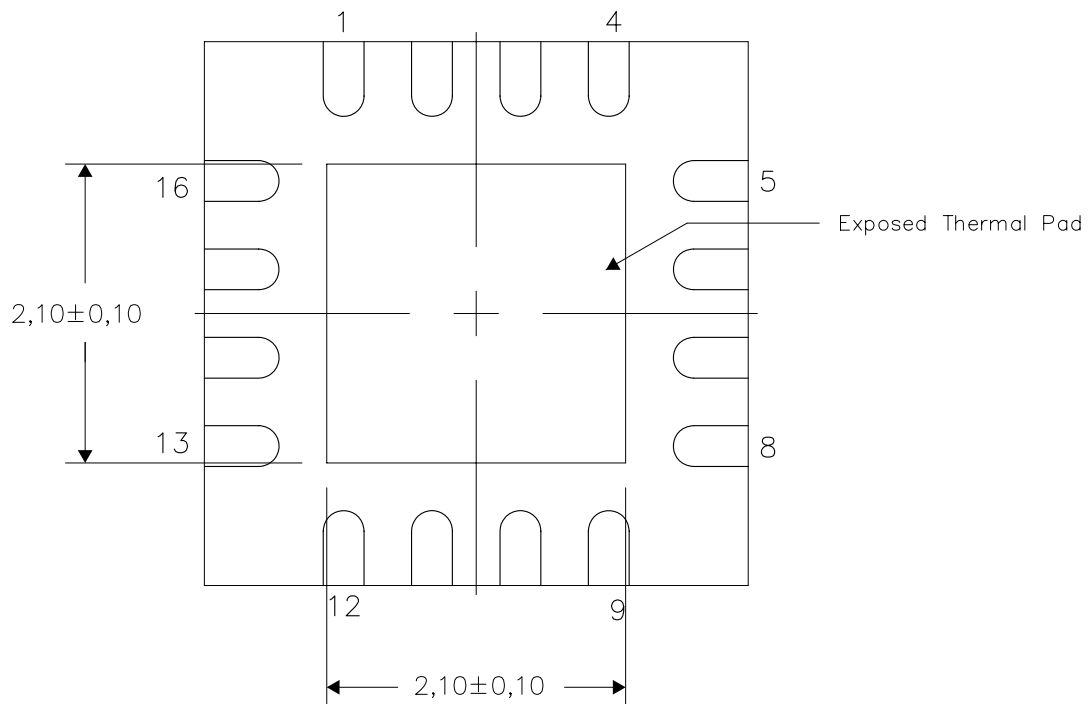

4206277-2/E 03/11

NOTE: A. All linear dimensions are in millimeters

RTY (S-PWQFN-N16)

PLASTIC QUAD FLATPACK NO-LEAD

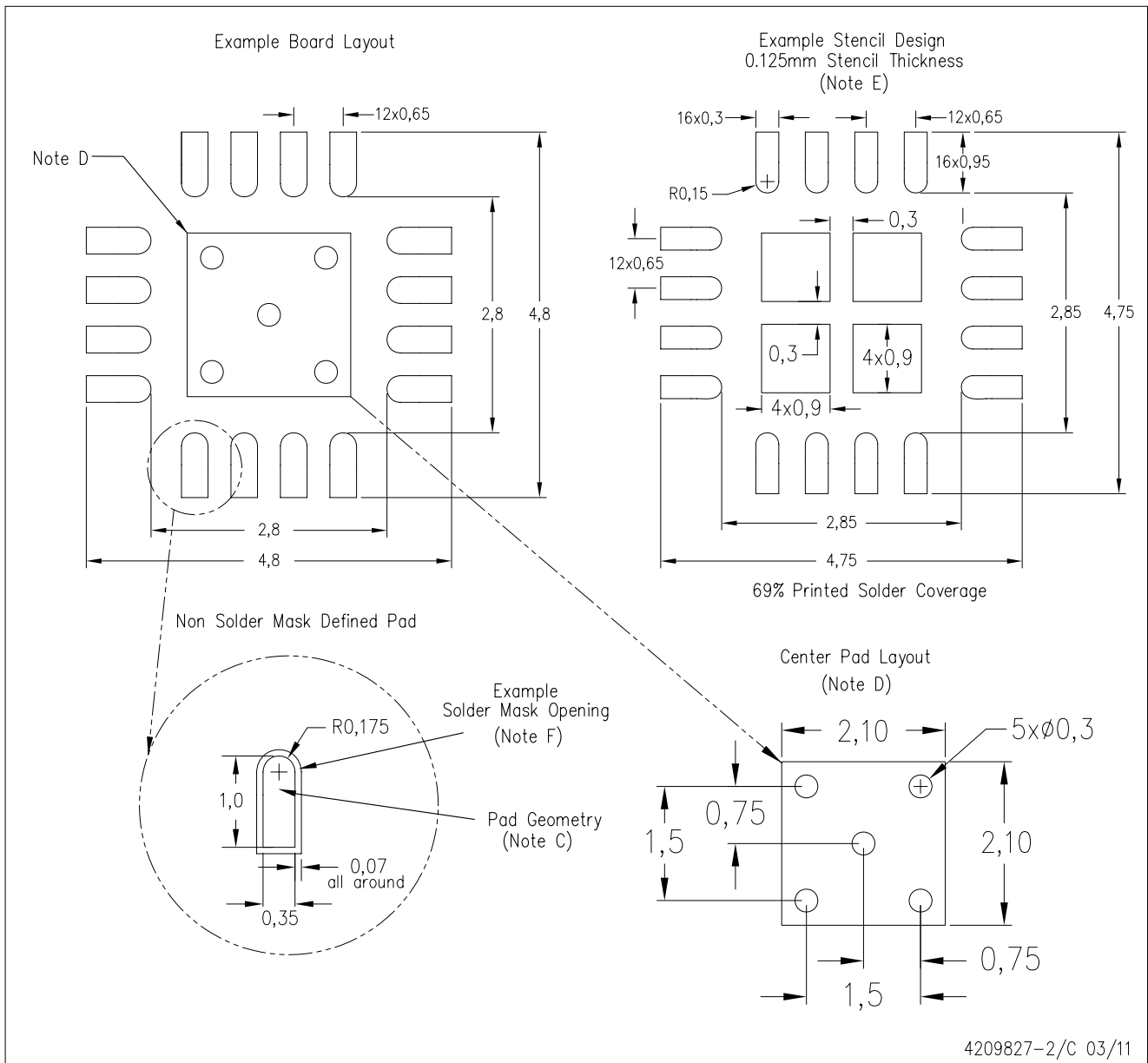

- NOTES: A. All linear dimensions are in millimeter.
 B. This drawing is subject to change without notice.
 C. Publication IPC-7351 is recommended for alternate designs.
 D. This package is designed to be soldered to a thermal pad on the board. Refer to Application Note, Quad Flat-Pack Packages, Texas Instruments Literature No. SLUA271, and also the Product Data Sheets for specific thermal information, via requirements, and recommended board layout. These documents are available at www.ti.com <<http://www.ti.com>>.
 E. Laser cutting apertures with trapezoidal walls and also rounding corners will offer better paste release. Customers should contact their board assembly site for stencil design recommendations. Refer to IPC 7525 for stencil design considerations.
 F. Customers should contact their board fabrication site for solder mask tolerances.

IMPORTANT NOTICE

Texas Instruments Incorporated and its subsidiaries (TI) reserve the right to make corrections, enhancements, improvements and other changes to its semiconductor products and services per JESD46, latest issue, and to discontinue any product or service per JESD48, latest issue. Buyers should obtain the latest relevant information before placing orders and should verify that such information is current and complete. All semiconductor products (also referred to herein as "components") are sold subject to TI's terms and conditions of sale supplied at the time of order acknowledgment.

TI warrants performance of its components to the specifications applicable at the time of sale, in accordance with the warranty in TI's terms and conditions of sale of semiconductor products. Testing and other quality control techniques are used to the extent TI deems necessary to support this warranty. Except where mandated by applicable law, testing of all parameters of each component is not necessarily performed.

TI assumes no liability for applications assistance or the design of Buyers' products. Buyers are responsible for their products and applications using TI components. To minimize the risks associated with Buyers' products and applications, Buyers should provide adequate design and operating safeguards.

TI does not warrant or represent that any license, either express or implied, is granted under any patent right, copyright, mask work right, or other intellectual property right relating to any combination, machine, or process in which TI components or services are used. Information published by TI regarding third-party products or services does not constitute a license to use such products or services or a warranty or endorsement thereof. Use of such information may require a license from a third party under the patents or other intellectual property of the third party, or a license from TI under the patents or other intellectual property of TI.

Reproduction of significant portions of TI information in TI data books or data sheets is permissible only if reproduction is without alteration and is accompanied by all associated warranties, conditions, limitations, and notices. TI is not responsible or liable for such altered documentation. Information of third parties may be subject to additional restrictions.

Resale of TI components or services with statements different from or beyond the parameters stated by TI for that component or service voids all express and any implied warranties for the associated TI component or service and is an unfair and deceptive business practice. TI is not responsible or liable for any such statements.

Buyer acknowledges and agrees that it is solely responsible for compliance with all legal, regulatory and safety-related requirements concerning its products, and any use of TI components in its applications, notwithstanding any applications-related information or support that may be provided by TI. Buyer represents and agrees that it has all the necessary expertise to create and implement safeguards which anticipate dangerous consequences of failures, monitor failures and their consequences, lessen the likelihood of failures that might cause harm and take appropriate remedial actions. Buyer will fully indemnify TI and its representatives against any damages arising out of the use of any TI components in safety-critical applications.

In some cases, TI components may be promoted specifically to facilitate safety-related applications. With such components, TI's goal is to help enable customers to design and create their own end-product solutions that meet applicable functional safety standards and requirements. Nonetheless, such components are subject to these terms.

No TI components are authorized for use in FDA Class III (or similar life-critical medical equipment) unless authorized officers of the parties have executed a special agreement specifically governing such use.

Only those TI components which TI has specifically designated as military grade or "enhanced plastic" are designed and intended for use in military/aerospace applications or environments. Buyer acknowledges and agrees that any military or aerospace use of TI components which have **not** been so designated is solely at the Buyer's risk, and that Buyer is solely responsible for compliance with all legal and regulatory requirements in connection with such use.

TI has specifically designated certain components as meeting ISO/TS16949 requirements, mainly for automotive use. In any case of use of non-designated products, TI will not be responsible for any failure to meet ISO/TS16949.

Products

Audio	www.ti.com/audio
Amplifiers	amplifier.ti.com
Data Converters	dataconverter.ti.com
DLP® Products	www.dlp.com
DSP	dsp.ti.com
Clocks and Timers	www.ti.com/clocks
Interface	interface.ti.com
Logic	logic.ti.com
Power Mgmt	power.ti.com
Microcontrollers	microcontroller.ti.com
RFID	www.ti-rfid.com
OMAP Applications Processors	www.ti.com/omap
Wireless Connectivity	www.ti.com/wirelessconnectivity

Applications

Automotive and Transportation	www.ti.com/automotive
Communications and Telecom	www.ti.com/communications
Computers and Peripherals	www.ti.com/computers
Consumer Electronics	www.ti.com/consumer-apps
Energy and Lighting	www.ti.com/energy
Industrial	www.ti.com/industrial
Medical	www.ti.com/medical
Security	www.ti.com/security
Space, Avionics and Defense	www.ti.com/space-avionics-defense
Video and Imaging	www.ti.com/video

TI E2E Community

e2e.ti.com