

**GigaDevice Semiconductor Inc.**

**GD32F330xx**

**ARM<sup>®</sup> Cortex<sup>®</sup>-M4 32-bit MCU**

Datasheet

# Table of Contents

<b>List of Figures</b> .....	<b>3</b>
<b>List of Tables</b> .....	<b>4</b>
<b>1 General description</b> .....	<b>5</b>
<b>2 Device overview</b> .....	<b>6</b>
2.1 Device information .....	6
2.2 Block diagram.....	7
2.3 Pinouts and pin assignment .....	8
2.4 Memory map.....	11
2.5 Clock tree .....	13
2.6 Pin definitions .....	14
<b>3 Functional description</b> .....	<b>22</b>
3.1 ARM® Cortex®-M4 core.....	22
3.2 On-chip memory.....	22
3.3 Clock, reset and supply management .....	23
3.4 Boot modes.....	23
3.5 Power saving modes .....	24
3.6 Analog to digital converter (ADC).....	25
3.7 DMA .....	25
3.8 General-purpose inputs/outputs (GPIOs).....	26
3.9 Timers and PWM generation.....	26
3.10 Real time clock (RTC) .....	27
3.11 Inter-integrated circuit (I2C).....	28
3.12 Serial peripheral interface (SPI).....	28
3.13 Universal synchronous asynchronous receiver transmitter (USART).....	28
3.14 Debug mode .....	29
3.15 Package and operation temperature.....	29
<b>4 Electrical characteristics</b> .....	<b>30</b>
4.1 Absolute maximum ratings .....	30
4.2 Recommended DC characteristics.....	30
4.3 Power consumption .....	31
4.4 EMC characteristics.....	32
4.5 Power supply supervisor characteristics .....	32
4.6 Electrical sensitivity.....	33
4.7 External clock characteristics.....	34
4.8 Internal clock characteristics .....	34
4.9 PLL characteristics .....	36
4.10 Memory characteristics .....	36
4.11 GPIO characteristics.....	37

---

4.12	ADC characteristics .....	38
4.13	I2C characteristics .....	40
4.14	SPI characteristics .....	40
4.15	USART characteristics .....	40
<b>5</b>	<b>Package information .....</b>	<b>41</b>
5.1	TSSOP package outline dimensions .....	41
5.2	QFN package outline dimensions .....	42
5.3	LQFP package outline dimensions .....	44
<b>6</b>	<b>Ordering Information .....</b>	<b>46</b>
<b>7</b>	<b>Revision History .....</b>	<b>47</b>

## List of Figures

Figure 1. GD32F330xx block diagram.....	7
Figure 2. GD32F330Rx LQFP64 pinouts.....	8
Figure 3. GD32F330Cx LQFP48 pinouts.....	8
Figure 4. GD32F330Kx QFN32 pinouts.....	9
Figure 5. GD32F330Gx QFN28 pinouts.....	9
Figure 6. GD32F330Fx TSSOP20 pinouts.....	10
Figure 7. GD32F330xx memory map.....	11
Figure 8. GD32F330xx clock tree.....	13
Figure 9. TSSOP package outline.....	41
Figure 10. QFN package outline.....	42
Figure 11. LQFP package outline.....	44

## List of Tables

Table 1. GD32F330xx devices features and peripheral list .....	6
Table 2. GD32F330xx pin definitions .....	14
Table 3. Port A alternate functions summary .....	18
Table 4. Port B alternate functions summary .....	19
Table 5. Port C alternate functions summary .....	20
Table 6. Port D alternate functions summary .....	20
Table 7. Port F alternate functions summary.....	21
Table 8. Absolute maximum ratings .....	30
Table 9. DC operating conditions .....	30
Table 10. Power consumption characteristics .....	31
Table 11. EMS characteristics .....	32
Table 12. EMI characteristics.....	32
Table 13 Power supply supervisor characteristics.....	32
Table 14. ESD characteristics.....	33
Table 15. Static latch-up characteristics .....	33
Table 16. High speed external clock (HXTAL) generated from a crystal/ceramic characteristics .....	34
Table 17. Low speed external clock (LXTAL) generated from a crystal/ceramic characteristics.....	34
Table 18. High speed internal clock (IRC8M) characteristics.....	34
Table 19. High speed internal clock (IRC48M) characteristics .....	35
Table 20. Low speed internal clock (IRC40K) characteristics .....	35
Table 21. PLL characteristics .....	36
Table 22. Flash memory characteristics .....	36
Table 23. I/O port characteristics.....	37
Table 24. ADC characteristics.....	38
Table 25. ADC $R_{AIN\ max}$ for $f_{ADC}=40MHz$ .....	38
Table 26. ADC dynamic accuracy at $f_{ADC} = 28 MHz$ .....	39
Table 27. ADC dynamic accuracy at $f_{ADC} = 30 MHz$ .....	39
Table 28. ADC dynamic accuracy at $f_{ADC} = 36 MHz$ .....	39
Table 29. ADC static accuracy at $f_{ADC} = 14 MHz$ .....	39
Table 30. I2C characteristics .....	40
Table 31. SPI characteristics.....	40
Table 32. USART characteristics .....	40
Table 33. TSSOP20 package dimensions .....	41
Table 34. QFN package dimensions .....	43
Table 35. LQFP package dimensions .....	45
Table 36. Part ordering code for GD32F330xx devices .....	46
Table 37. Revision history.....	47

## 1 General description

The GD32F330xx device belongs to the value line of GD32 MCU family. It is a new 32-bit general-purpose microcontroller based on the ARM® Cortex®-M4 RISC core with best cost-performance ratio in terms of enhanced processing capacity, reduced power consumption and peripheral set. The Cortex®-M4 core features implements a full set of DSP instructions to address digital signal control markets that demand an efficient, easy-to-use blend of control and signal processing capabilities. It also provides a Memory Protection Unit (MPU) and powerful trace technology for enhanced application security and advanced debug support.

The GD32F330xx device incorporates the ARM® Cortex®-M4 32-bit processor core operating at 84 MHz frequency with Flash accesses zero wait states to obtain maximum efficiency. It provides up to 128 KB on-chip Flash memory and up to 16 KB SRAM memory. An extensive range of enhanced I/Os and peripherals connected to two APB buses. The devices offer one 12-bit ADC, up to five general-purpose 16-bit timers, a general-purpose 32-bit timer, a PWM advanced-control timer, as well as standard and advanced communication interfaces: up to two SPIs, two I<sup>2</sup>Cs, two USARTs.

The device operates from a 2.6 to 3.6 V power supply and available in –40 to +85 °C temperature range. Several power saving modes provide the flexibility for maximum optimization between wakeup latency and power consumption, an especially important consideration in low power applications.

The above features make the GD32F330xx devices suitable for a wide range of applications, especially in areas such as industrial control, motor drives, user interface, power monitor and alarm systems, consumer and handheld equipment, gaming and GPS, E-bike and so on.



## 2 Device overview

### 2.1 Device information

**Table 1. GD32F330xx devices features and peripheral list**

Part Number		GD32F330xx														
		F4	F6	F8	G4	G6	G8	K4	K6	K8	C4	C6	C8	CB	R8	RB
Flash	Code Area (KB)	16	32	64	16	32	64	16	32	64	16	32	64	64	64	64
	Data Area (KB)	0	0	0	0	0	0	0	0	0	0	0	0	64	0	64
	Total (KB)	16	32	64	16	32	64	16	32	64	16	32	64	128	64	128
SRAM (KB)		4	4	8	4	4	8	4	4	8	4	4	8	16	16	16
Timers	32-bit GP	1	1	1	1	1	1	1	1	1	1	1	1	1	1	1
	16-bit GP	4	4	4	4	4	5	4	4	5	4	4	5	5	5	5
	16-bit Adv.	1	1	1	1	1	1	1	1	1	1	1	1	1	1	1
	SysTick	1	1	1	1	1	1	1	1	1	1	1	1	1	1	1
	Watchdog	2	2	2	2	2	2	2	2	2	2	2	2	2	2	2
	RTC	1	1	1	1	1	1	1	1	1	1	1	1	1	1	1
Connectiv	USART	1	2	2	1	2	2	1	2	2	1	2	2	2	2	2
	I2C	1	1	2	1	1	2	1	1	2	1	1	2	2	2	2
	SPI	1	1	2	1	1	2	1	1	2	1	1	2	2	2	2
GPIO		15	15	15	23	23	23	27	27	27	39	39	39	39	55	55
EXTI		16	16	16	16	16	16	16	16	16	16	16	16	16	16	16
ADC	Units	1	1	1	1	1	1	1	1	1	1	1	1	1	1	1
	Channels (Ext.)	9	9	9	10	10	10	10	10	10	10	10	10	10	16	16
	Channels (Int.)	3	3	3	3	3	3	3	3	3	3	3	3	3	3	3
Package		TSSOP20			QFN28			QFN32			LQFP48				LQFP64	

## 2.2 Block diagram

Figure 1. GD32F330xx block diagram

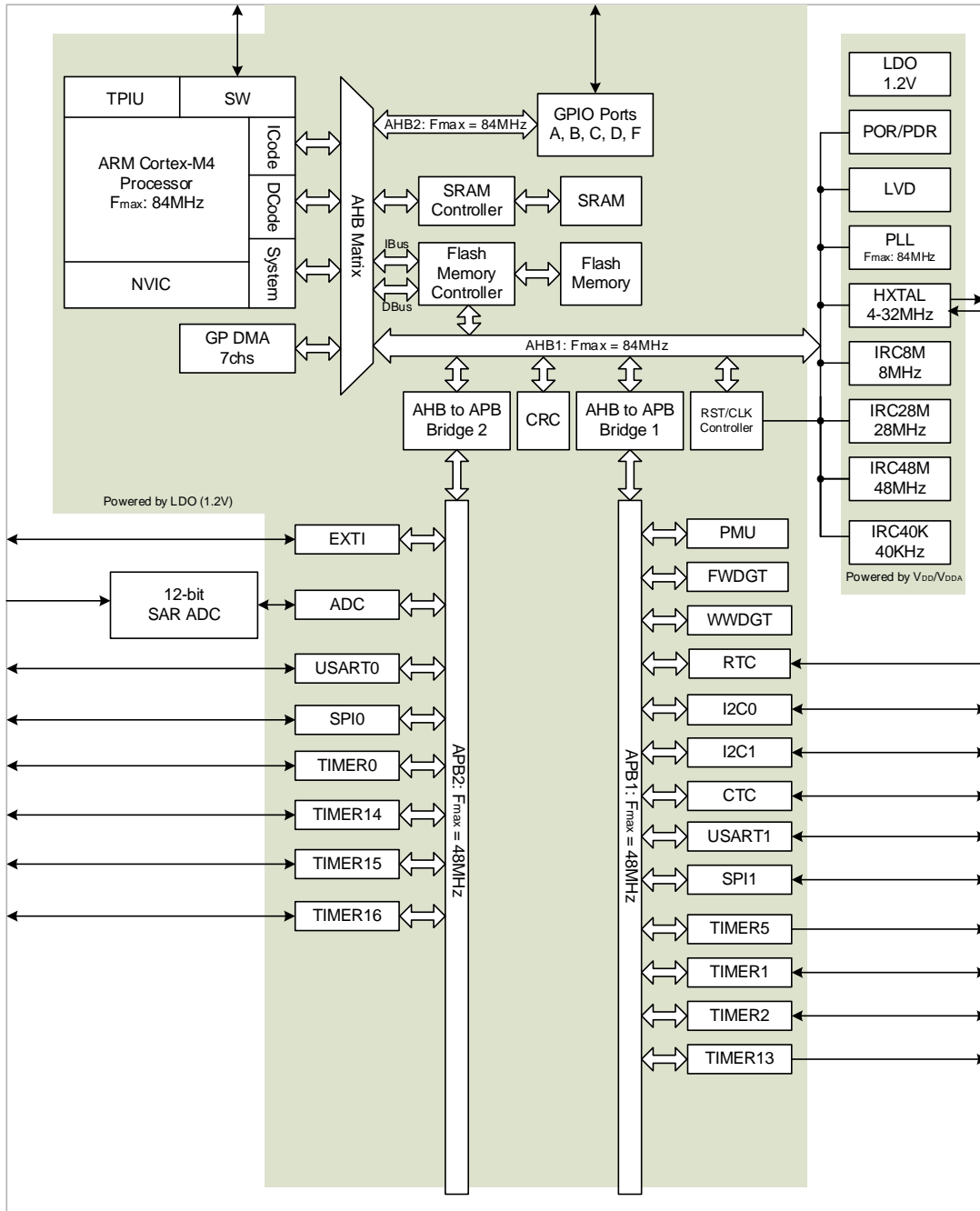



## 2.3 Pinouts and pin assignment

Figure 2. GD32F330Rx LQFP64 pinouts

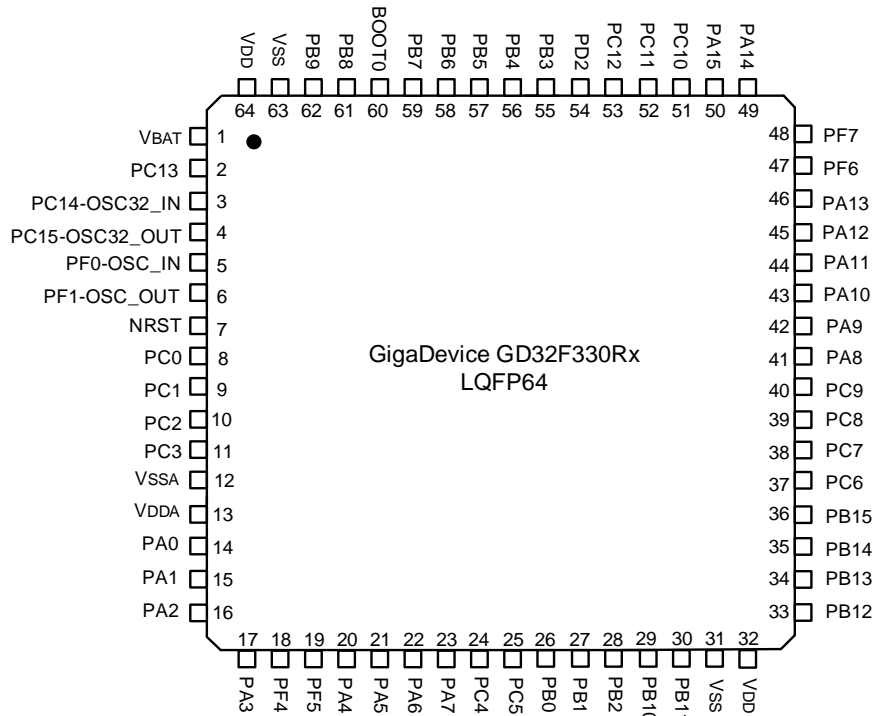

Figure 3. GD32F330Cx LQFP48 pinouts

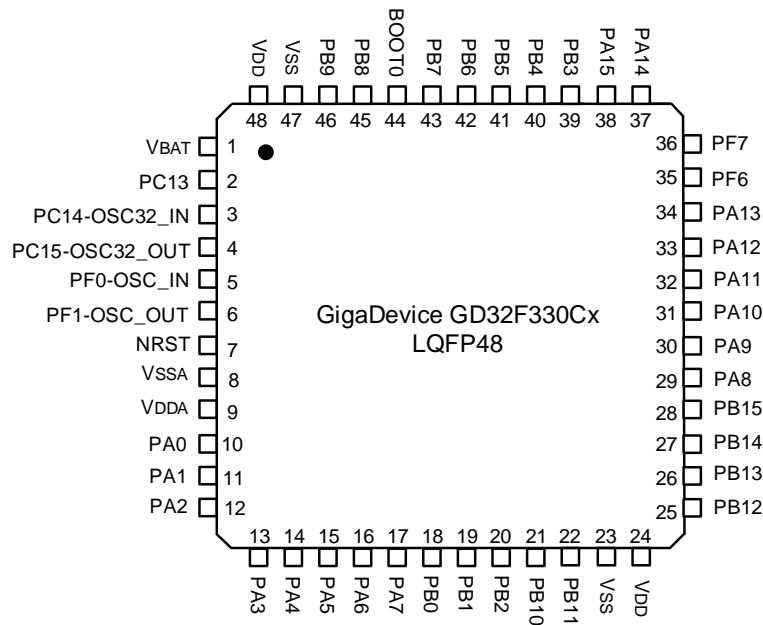

Figure 4. GD32F330Kx QFN32 pinouts

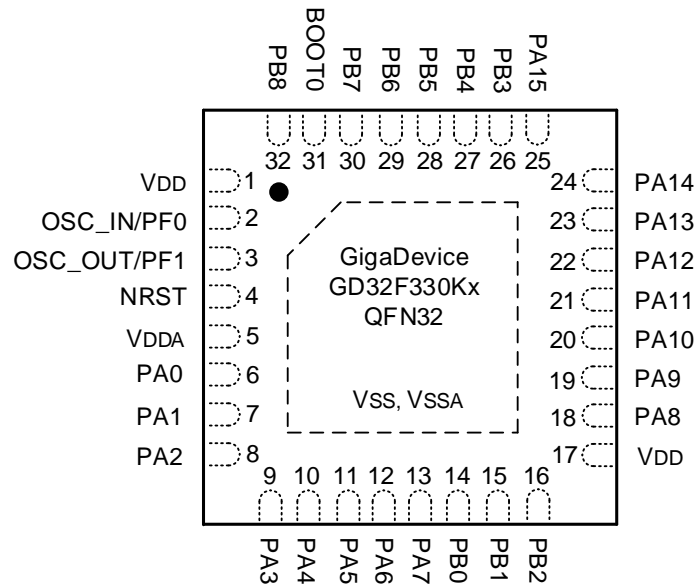

Figure 5. GD32F330Gx QFN28 pinouts

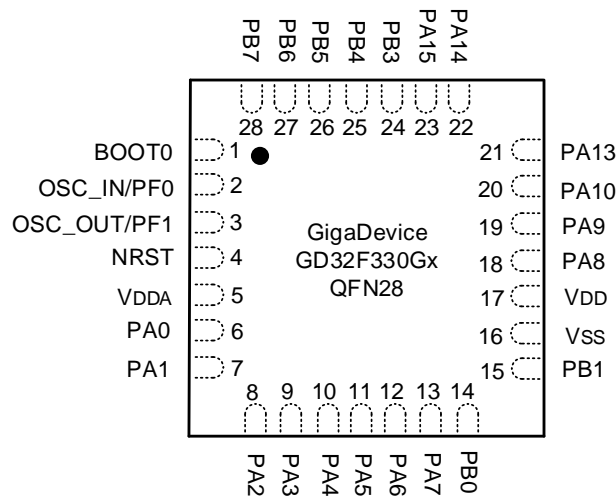
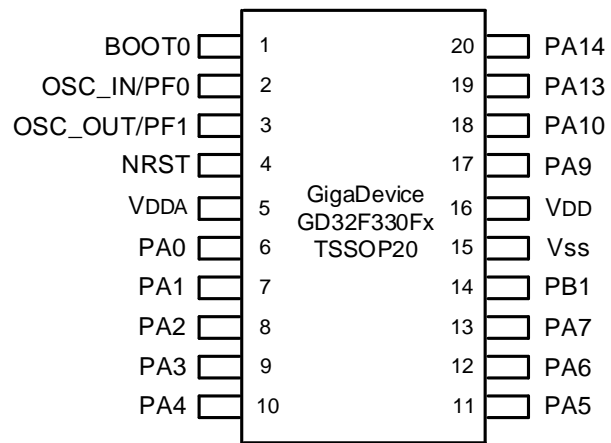

Figure 6. GD32F330Fx TSSOP20 pinouts



## 2.4 Memory map

Figure 7. GD32F330xx memory map

Pre-defined Regions	Bus	ADDRESS	Peripherals
		0xE000 0000 - 0xE00F FFFF	Cortex-M4 internal peripherals
External Device		0xA000 0000 - 0xDFFF FFFF	Reserved
External RAM		0x6000 0000 - 0x9FFF FFFF	Reserved
Peripherals	AHB1	0x5004 0000 - 0x5FFF FFFF	Reserved
		0x5000 0000 - 0x5003 FFFF	Reserved
	AHB2	0x4800 1800 - 0x4FFF FFFF	Reserved
		0x4800 1400 - 0x4800 17FF	GPIOF
		0x4800 1000 - 0x4800 13FF	Reserved
		0x4800 0C00 - 0x4800 0FFF	GPIOD
		0x4800 0800 - 0x4800 0BFF	GPIOC
		0x4800 0400 - 0x4800 07FF	GPIOB
		0x4800 0000 - 0x4800 03FF	GPIOA
	AHB1	0x4002 4400 - 0x47FF FFFF	Reserved
		0x4002 4000 - 0x4002 43FF	Reserved
		0x4002 3400 - 0x4002 3FFF	Reserved
		0x4002 3000 - 0x4002 33FF	CRC
		0x4002 2400 - 0x4002 2FFF	Reserved
		0x4002 2000 - 0x4002 23FF	FMC
		0x4002 1400 - 0x4002 1FFF	Reserved
		0x4002 1000 - 0x4002 13FF	RCU
		0x4002 0400 - 0x4002 0FFF	Reserved
		0x4002 0000 - 0x4002 03FF	DMA
	APB2	0x4001 8000 - 0x4001 FFFF	Reserved
		0x4001 5C00 - 0x4001 7FFF	Reserved
		0x4001 4C00 - 0x4001 5BFF	Reserved
		0x4001 4800 - 0x4001 4BFF	TIMER16
		0x4001 4400 - 0x4001 47FF	TIMER15
		0x4001 4000 - 0x4001 43FF	TIMER14
		0x4001 3C00 - 0x4001 3FFF	Reserved
		0x4001 3800 - 0x4001 3BFF	USART0
		0x4001 3400 - 0x4001 37FF	Reserved
		0x4001 3000 - 0x4001 33FF	SPI0
		0x4001 2C00 - 0x4001 2FFF	TIMER0
		0x4001 2800 - 0x4001 2BFF	Reserved
		0x4001 2400 - 0x4001 27FF	ADC
	0x4001 0800 - 0x4001 23FF	Reserved	
	0x4001 0400 - 0x4001 07FF	EXTI	

Pre-defined Regions	Bus	ADDRESS	Peripherals
	APB1	0x4001 0000 - 0x4001 03FF	SYSCFG
		0x4000 CC00 - 0x4000 FFFF	Reserved
		0x4000 C800 - 0x4000 CBFF	CTC
		0x4000 C400 - 0x4000 C7FF	Reserved
		0x4000 C000 - 0x4000 C3FF	Reserved
		0x4000 8000 - 0x4000 BFFF	Reserved
		0x4000 7C00 - 0x4000 7FFF	Reserved
		0x4000 7800 - 0x4000 7BFF	Reserved
		0x4000 7400 - 0x4000 77FF	Reserved
		0x4000 7000 - 0x4000 73FF	PMU
		0x4000 6400 - 0x4000 6FFF	Reserved
		0x4000 6000 - 0x4000 63FF	Reserved
		0x4000 5C00 - 0x4000 5FFF	Reserved
		0x4000 5800 - 0x4000 5BFF	I2C1
		0x4000 5400 - 0x4000 57FF	I2C0
		0x4000 4800 - 0x4000 53FF	Reserved
		0x4000 4400 - 0x4000 47FF	USART1
		0x4000 4000 - 0x4000 43FF	Reserved
		0x4000 3C00 - 0x4000 3FFF	Reserved
		0x4000 3800 - 0x4000 3BFF	SPI1
		0x4000 3400 - 0x4000 37FF	Reserved
		0x4000 3000 - 0x4000 33FF	FWDGT
		0x4000 2C00 - 0x4000 2FFF	WWDGT
		0x4000 2800 - 0x4000 2BFF	RTC
		0x4000 2400 - 0x4000 27FF	Reserved
		0x4000 2000 - 0x4000 23FF	TIMER13
		0x4000 1400 - 0x4000 1FFF	Reserved
		0x4000 1000 - 0x4000 13FF	TIMER5
		0x4000 0800 - 0x4000 0FFF	Reserved
		0x4000 0400 - 0x4000 07FF	TIMER2
		0x4000 0000 - 0x4000 03FF	TIMER1
		SRAM	
0x2000 0000 - 0x2000 4FFF	SRAM		
Code		0x1FFF FC00 - 0x1FFF FFFF	Reserved
		0x1FFF F800 - 0x1FFF FBFF	Option bytes
		0x1FFF EC00 - 0x1FFF F7FF	System memory
		0x0810 0000 - 0x1FFF EBFF	Reserved
		0x0800 0000 - 0x080F FFFF	Main Flash memory
		0x0010 0000 - 0x07FF FFFF	Reserved
		0x0000 0000 - 0x000F FFFF	Aliased to Flash or system memory



## 2.6 Pin definitions

**Table 2. GD32F330xx pin definitions**

Pin Name	Pins					Pin Type <sup>(1)</sup>	I/O <sup>(2)</sup> Level	Functions description
	LQFP64	LQFP48	QFN32	QFN28	TSSOP20			
V <sub>BAT</sub>	1	1		-	-	P		Default: V <sub>BAT</sub>
PC13-TAMPER-RTC	2	2		-	-	I/O		Default: PC13 Additional: RTC_TAMP0, RTC_TS, RTC_OUT, WKUP1
PC14-OSC32IN	3	3		-	-	I/O		Default: PC14 Additional: OSC32IN
PC15-OSC32OUT	4	4		-	-	I/O		Default: PC15 Additional: OSC32OUT
PF0-OSCIN	5	5	2	2	2	I/O	5VT	Default: PF0 Alternate: CTC_SYNC Additional: OSCIN
PF1-OSCOU	6	6	3	3	3	I/O	5VT	Default: PF1 Additional: OSCOUT
NRST	7	7	4	4	4	I/O		Default: NRST
PC0	8	-		-	-	I/O		Default: PC0 Alternate: EVENTOUT Additional: ADC_IN10
PC1	9	-		-	-	I/O		Default: PC1 Alternate: EVENTOUT Additional: ADC_IN11
PC2	10	-		-	-	I/O		Default: PC2 Alternate: EVENTOUT Additional: ADC_IN12
PC3	11	-		-	-	I/O		Default: PC3 Alternate: EVENTOUT Additional: ADC_IN13
V <sub>SSA</sub>	12	8		-	-	P		Default: V <sub>SSA</sub>
V <sub>DDA</sub>	13	9	5	5	5	P		Default: V <sub>DDA</sub>
PA0-WKUP	14	10	6	6	6	I/O		Default: PA0 Alternate: USART0_CTS <sup>(3)</sup> , USART1_CTS <sup>(4)</sup> , TIMER1_CH0, TIMER1_ETI, I2C1_SCL Additional: ADC_IN0, RTC_TAMP1, WKUP0
PA1	15	11	7	7	7	I/O		Default: PA1 Alternate: USART0_RTS <sup>(3)</sup> , USART1_RTS <sup>(4)</sup> , TIMER1_CH1, I2C1_SDA, EVENTOUT Additional: ADC_IN1

Pin Name	Pins					Pin Type <sup>(1)</sup>	I/O <sup>(2)</sup> Level	Functions description
	LQFP64	LQFP48	QFN32	QFN28	TSSOP20			
PA2	16	12	8	8	8	I/O		Default: PA2 Alternate: USART0_TX <sup>(3)</sup> , USART1_TX <sup>(4)</sup> , TIMER1_CH2, TIMER14_CH0 Additional: ADC_IN2
PA3	17	13	9	9	9	I/O		Default: PA3 Alternate: USART0_RX <sup>(3)</sup> , USART1_RX <sup>(4)</sup> , TIMER1_CH3, TIMER14_CH1 Additional: ADC_IN3
PF4	18	-	-	-	-	I/O	5VT	Default: PF4 Alternate: EVENTOUT
PF5	19	-	-	-	-	I/O	5VT	Default: PF5 Alternate: EVENTOUT
PA4	20	14	10	10	10	I/O		Default: PA4 Alternate: SPI0_NSS, USART0_CK <sup>(3)</sup> , USART1_CK <sup>(4)</sup> , TIMER13_CH0, SPI1_NSS Additional: ADC_IN4
PA5	21	15	11	11	11	I/O		Default: PA5 Alternate: SPI0_SCK, TIMER1_CH0, TIMER1_ETI Additional: ADC_IN5
PA6	22	16	12	12	12	I/O		Default: PA6 Alternate: SPI0_MISO, TIMER2_CH0, TIMER0_BKIN, TIMER15_CH0, EVENTOUT Additional: ADC_IN6
PA7	23	17	13	13	13	I/O		Default: PA7 Alternate: SPI0_MOSI, TIMER2_CH1, TIMER13_CH0, TIMER0_CH0_ON, TIMER16_CH0, EVENTOUT Additional: ADC_IN7
PC4	24	-	-	-	-	I/O		Default: PC4 Alternate: EVENTOUT Additional: ADC_IN14
PC5	25	-	-	-	-	I/O		Default: PC5 Additional: ADC_IN15, WKUP4
PB0	26	18	14	14	-	I/O		Default: PB0 Alternate: TIMER2_CH2, TIMER0_CH1_ON, USART1_RX, EVENTOUT Additional: ADC_IN8
PB1	27	19	15	15	14	I/O		Default: PB1 Alternate: TIMER2_CH3, TIMER13_CH0, TIMER0_CH2_ON, SPI1_SCK Additional: ADC_IN9
PB2	28	20	16	-	-	I/O	5VT	Default: PB2
PB10	29	21	-	-	-	I/O	5VT	Default: PB10 Alternate: I2C0_SCL <sup>(3)</sup> , I2C1_SCL <sup>(4)</sup> , TIMER1_CH2, SPI1_IO2



Pin Name	Pins					Pin Type <sup>(1)</sup>	I/O <sup>(2)</sup> Level	Functions description
	LQFP64	LQFP48	QFN32	QFN28	TSSOP20			
PB11	30	22		-	-	I/O	5VT	Default: PB11 Alternate: I2C0_SDA <sup>(3)</sup> , I2C1_SDA <sup>(4)</sup> , TIMER1_CH3, EVENTOUT, SPI1_IO3
V <sub>SS</sub>	31	23		16	15	P		Default: V <sub>SS</sub>
V <sub>DD</sub>	32	24	17	17	16	P		Default: V <sub>DD</sub>
PB12	33	25		-	-	I/O	5VT	Default: PB12 Alternate: SPI0_NSS <sup>(3)</sup> , SPI1_NSS <sup>(4)</sup> , TIMER0_BKIN, I2C1_SMBA, EVENTOUT
PB13	34	26		-	-	I/O	5VT	Default: PB13 Alternate: SPI0_SCK <sup>(3)</sup> , SPI1_SCK <sup>(4)</sup> , TIMER0_CH0_ON
PB14	35	27		-	-	I/O	5VT	Default: PB14 Alternate: SPI0_MISO <sup>(3)</sup> , SPI1_MISO <sup>(4)</sup> , TIMER0_CH1_ON, TIMER14_CH0
PB15	36	28		-	-	I/O	5VT	Default: PB15 Alternate: SPI0_MOSI <sup>(3)</sup> , SPI1_MOSI <sup>(4)</sup> , TIMER0_CH2_ON, TIMER14_CH0_ON, TIMER14_CH1 Additional: RTC_REFIN, WKUP6
PC6	37	-		-	-	I/O	5VT	Default: PC6 Alternate: TIMER2_CH0
PC7	38	-		-	-	I/O	5VT	Default: PC7 Alternate: TIMER2_CH1
PC8	39	-		-	-	I/O	5VT	Default: PC8 Alternate: TIMER2_CH2
PC9	40	-		-	-	I/O	5VT	Default: PC9 Alternate: TIMER2_CH3
PA8	41	29	18	18	-	I/O	5VT	Default: PA8 Alternate: USART0_CK, TIMER0_CH0, CK_OUT, USART1_TX, EVENTOUT, CTC_SYNC
PA9	42	30	19	19	17	I/O	5VT	Default: PA9 Alternate: USART0_TX, TIMER0_CH1, TIMER14_BKIN, I2C0_SCL
PA10	43	31	20	20	18	I/O	5VT	Default: PA10 Alternate: USART0_RX, TIMER0_CH2, TIMER16_BKIN, I2C0_SDA
PA11	44	32	21	-	-	I/O	5VT	Default: PA11 Alternate: USART0_CTS, TIMER0_CH3, EVENTOUT, SPI1_IO2
PA12	45	33	22	-	-	I/O	5VT	Default: PA12 Alternate: USART0_RTS, TIMER0_ETI, EVENTOUT, SPI1_IO3
PA13	46	34	23	21	19	I/O	5VT	Default: PA13 Alternate: IFRP_OUT, SWDIO, SPI1_MISO
PF6	47	35		-	-	I/O	5VT	Default: PF6 Alternate: I2C0_SCL <sup>(3)</sup> , I2C1_SCL <sup>(4)</sup>
PF7	48	36		-	-	I/O	5VT	Default: PF7 Alternate: I2C0_SDA <sup>(3)</sup> , I2C1_SDA <sup>(4)</sup>

Pin Name	Pins					Pin Type <sup>(1)</sup>	I/O <sup>(2)</sup> Level	Functions description
	LQFP64	LQFP48	QFN32	QFN28	TSSOP20			
PA14	49	37	24	22	20	I/O	5VT	Default: PA14 Alternate: USART0_TX <sup>(3)</sup> , USART1_TX <sup>(4)</sup> , SWCLK, SPI1_MOSI
PA15	50	38	25	23	-	I/O	5VT	Default: PA15 Alternate: SPI0_NSS, USART0_RX <sup>(3)</sup> , USART1_RX <sup>(4)</sup> , TIMER1_CH0, TIMER1_ETI, SPI1_NSS, EVENTOUT
PC10	51	-	-	-	-	I/O	5VT	Default: PC10
PC11	52	-	-	-	-	I/O	5VT	Default: PC11
PC12	53	-	-	-	-	I/O	5VT	Default: PC12
PD2	54	-	-	-	-	I/O	5VT	Default: PD2 Alternate: TIMER2_ETI
PB3	55	39	26	24	-	I/O	5VT	Default: PB3 Alternate: SPI0_SCK, TIMER1_CH1, EVENTOUT
PB4	56	40	27	25	-	I/O	5VT	Default: PB4 Alternate: SPI0_MISO, TIMER2_CH0, EVENTOUT
PB5	57	41	28	26	-	I/O	5VT	Default: PB5 Alternate: SPI0_MOSI, I2C0_SMBA, TIMER15_BKIN, TIMER2_CH1 Additional:WKUP5
PB6	58	42	29	27	-	I/O	5VT	Default: PB6 Alternate: I2C0_SCL, USART0_TX, TIMER15_CH0_ON
PB7	59	43	30	28	-	I/O	5VT	Default: PB7 Alternate: I2C0_SDA, USART0_RX, TIMER16_CH0_ON
BOOT0	60	44	31	1	1	I		Default: BOOT0
PB8	61	45	32	-	-	I/O	5VT	Default: PB8 Alternate: I2C0_SCL, TIMER15_CH0
PB9	62	46	-	-	-	I/O	5VT	Default: PB9 Alternate: I2C0_SDA, IFRP_OUT, TIMER16_CH0, EVENTOUT
V <sub>SS</sub>	63	47	-	-	-	P		Default: V <sub>SS</sub>
V <sub>DD</sub>	64	48	1	-	-	P		Default: V <sub>DD</sub>

**Notes:**

1. Type: I = input, O = output, P = power.
2. I/O Level: 5VT = 5 V tolerant.
3. This feature is available on GD32F330x4 devices only.
4. This feature is available on GD32F330xB, GD32F330x8 and GD32F330x6 devices only.

**Table 3. Port A alternate functions summary**

Pin Name	AF0	AF1	AF2	AF3	AF4	AF5	AF6
PA0		USART0_CTS <sup>(1)</sup> USART1_CTS <sup>(2)</sup>	TIMER1_CH0 TIMER1_ETI		I2C1_SCL		
PA1	EVENTOUT	USART0_RTS <sup>(1)</sup> USART1_RTS <sup>(2)</sup>	TIMER1_CH1		I2C1_SDA		
PA2	TIMER14_CH0	USART0_TX <sup>(1)</sup> USART1_TX <sup>(2)</sup>	TIMER1_CH2				
PA3	TIMER14_CH1	USART0_RX <sup>(1)</sup> USART1_RX <sup>(2)</sup>	TIMER1_CH3				
PA4	SPI0_NSS	USART0_CK <sup>(1)</sup> USART1_CK <sup>(2)</sup>			TIMER13_CH0		SPI1_NSS
PA5	SPI0_SCK		TIMER1_CH0/ TIMER1_ETI				
PA6	SPI0_MISO	TIMER2_CH0	TIMER0_BKIN			TIMER15_CH0	EVENTOUT
PA7	SPI0_MOSI	TIMER2_CH1	TIMER0_CH0_ON		TIMER13_CH0	TIMER16_CH0	EVENTOUT
PA8	CK_OUT	USART0_CK	TIMER0_CH0	EVENTOUT	USART1_TX		CTC_SYNC
PA9	TIMER14_BKIN	USART0_TX	TIMER0_CH1		I2C0_SCL		
PA10	TIMER16_BKIN	USART0_RX	TIMER0_CH2		I2C0_SDA		
PA11	EVENTOUT	USART0_CTS	TIMER0_CH3				SPI1_IO2
PA12	EVENTOUT	USART0_RTS	TIMER0_ETI				SPI1_IO3
PA13	SWDIO	IFRP_OUT					SPI1_MISO
PA14	SWCLK	USART0_TX <sup>(1)</sup> USART1_TX <sup>(2)</sup>					SPI1_MOSI
PA15	SPI0_NSS	USART0_RX <sup>(1)</sup> USART1_RX <sup>(2)</sup>	TIMER1_CH0/ TIMER1_ ETI	EVENTOUT			SPI1_NSS

1. This feature is available on GD32F330x4 devices only.

2. This feature is available on GD32F330xB, GD32F330x8 and GD32F330x6 devices only.

**Table 4. Port B alternate functions summary**

Pin Name	AF0	AF1	AF2	AF3	AF4	AF5	AF6
PB0	EVENTOUT	TIMER2_CH2	TIMER0_CH1_ON		USART1_RX		
PB1	TIMER13_CH0	TIMER2_CH3	TIMER0_CH2_ON				SPI1_SCK
PB2							
PB3	SPI0_SCK	EVENTOUT	TIMER1_CH1				
PB4	SPI0_MISO	TIMER2_CH0	EVENTOUT				
PB5	SPI0_MOSI	TIMER2_CH1	TIMER15_BKIN	I2C0_SMBA			
PB6	USART0_TX	I2C0_SCL	TIMER15_CH0_ON				
PB7	USART0_RX	I2C0_SDA	TIMER16_CH0_ON				
PB8		I2C0_SCL	TIMER15_CH0				
PB9	IFRP_OUT	I2C0_SDA	TIMER16_CH0	EVENTOUT			
PB10		I2C0_SCL <sup>(1)</sup> , I2C1_SCL <sup>(2)</sup>	TIMER1_CH2				SPI1_IO2
PB11	EVENTOUT	I2C0_SDA <sup>(1)</sup> , I2C1_SDA <sup>(2)</sup>	TIMER1_CH3				SPI1_IO3
PB12	SPI0_NSS <sup>(1)</sup> , SPI1_NSS <sup>(2)</sup>	EVENTOUT	TIMER0_BKIN		I2C1_SMBA		
PB13	SPI0_SCK <sup>(1)</sup> , SPI1_SCK <sup>(2)</sup>		TIMER0_CH0_ON				
PB14	SPI0_MISO <sup>(1)</sup> , SPI1_MISO <sup>(2)</sup>	TIMER14_CH0	TIMER0_CH1_ON				
PB15	SPI0_MOSI <sup>(1)</sup> , SPI1_MOSI <sup>(2)</sup>	TIMER14_CH1	TIMER0_CH2_ON	TIMER14_CH0_ON			

1. This feature is available on GD32F330x4 devices only.

2. This feature is available on GD32F330xB, GD32F330x8 and GD32F330x6 devices only.

**Table 5. Port C alternate functions summary**

Pin Name	AF0	AF1	AF2	AF3	AF4	AF5	AF6
PC0	EVENTOUT						
PC1	EVENTOUT						
PC2	EVENTOUT						
PC3	EVENTOUT						
PC4	EVENTOUT						
PC5							
PC6	TIMER2_CH0						
PC7	TIMER2_CH1						
PC8	TIMER2_CH2						
PC9	TIMER2_CH3						
PC10							
PC11							
PC12							
PC13							
PC14							
PC15							

**Table 6. Port D alternate functions summary**

Pin Name	AF0	AF1	AF2	AF3	AF4	AF5	AF6
PD0							
PD1							
PD2	TIMER2_ETI						
PD3							
PD4							
PD5							
PD6							
PD7							
PD8							
PD9							
PD10							
PD11							
PD12							
PD13							
PD14							
PD15							

**Table 7. Port F alternate functions summary**

Pin Name	AF0	AF1	AF2	AF3	AF4	AF5	AF6
PF0	CTC_SYNC						
PF1							
PF2							
PF3							
PF4	EVENTOUT						
PF5	EVENTOUT						
PF6	I2C0_SCL <sup>(1)</sup> I2C1_SCL <sup>(2)</sup>						
PF7	I2C0_SDA <sup>(1)</sup> I2C1_SDA <sup>(2)</sup>						
PF8							
PF9							
PF10							
PF11							
PF12							
PF13							
PF14							
PF15							

1. This feature is available on GD32F330x4 devices only.

2. This feature is available on GD32F330xB, GD32F330x8 and GD32F330x6 devices only.

## 3 Functional description

### 3.1 ARM® Cortex®-M4 core

The ARM® Cortex®-M4 processor is a high performance embedded processor with DSP instructions which allow efficient signal processing and complex algorithm execution. It brings an efficient, easy-to-use blend of control and signal processing capabilities to meet the digital signal control markets demand. The processor is highly configurable enabling a wide range of implementations from those requiring memory protection and powerful trace technology to cost sensitive devices requiring minimal area, while delivering outstanding computational performance and an advanced system response to interrupts.

32-bit ARM® Cortex®-M4 processor core

- Up to 84 MHz operation frequency
- Single-cycle multiplication and hardware divider
- Integrated DSP instructions
- Integrated Nested Vectored Interrupt Controller (NVIC)
- 24-bit SysTick timer

The Cortex®-M4 processor is based on the ARMv7-M architecture and supports both Thumb and Thumb-2 instruction sets. Some system peripherals listed below are also provided by Cortex®-M4:

- Internal Bus Matrix connected with ICode bus, DCode bus, system bus, Private Peripheral Bus (PPB) and debug accesses (AHB-AP)
- Nested Vectored Interrupt Controller (NVIC)
- Flash Patch and Breakpoint (FPB)
- Data Watchpoint and Trace (DWT)
- Instrument Trace Macrocell (ITM)
- Memory Protection Unit (MPU)
- Serial Wire JTAG Debug Port (SWJ-DP)
- Trace Port Interface Unit (TPIU)

### 3.2 On-chip memory

- Up to 128 Kbytes of Flash memory
- Up to 16 Kbytes of SRAM with hardware parity checking

The ARM® Cortex®-M4 processor is structured in Harvard architecture which can use separate buses to fetch instructions and load/store data. 128 Kbytes of inner Flash and 16 Kbytes of inner SRAM at most is available for storing programs and data, both accessed (R/W) at CPU clock speed with zero wait states. The Figure 7. GD32F330xx memory map shows the memory map of the GD32F330xx series of devices, including code, SRAM, peripheral, and other pre-defined regions.

### 3.3 Clock, reset and supply management

- Internal 8 MHz factory-trimmed RC and external 4 to 32 MHz crystal oscillator
- Internal 48 MHz RC oscillator
- Internal 40 KHz RC calibrated oscillator and external 32.768 KHz crystal oscillator
- Integrated system clock PLL
- 2.6 to 3.6 V application supply and I/Os
- Supply Supervisor: POR (Power On Reset), PDR (Power Down Reset), and low voltage detector (LVD)

The Clock Control Unit (CCU) provides a range of oscillator and clock functions. These include speed internal RC oscillator and external crystal oscillator, high speed and low speed two types. Several prescalers allow the frequency configuration of the AHB and two APB domains. The maximum frequency of the AHB and two APB domains is 84 MHz. See Figure 8 for details on the clock tree.

The Reset Control Unit (RCU) controls three kinds of reset: system reset resets the processor core and peripheral IP components. Power-on reset (POR) and power-down reset (PDR) are always active, and ensures proper operation starting from 2.6 V and down to 1.8V. The device remains in reset mode when  $V_{DD}$  is below a specified threshold. The embedded low voltage detector (LVD) monitors the power supply, compares it to the voltage threshold and generates an interrupt as a warning message for leading the MCU into security.

Power supply schemes:

- $V_{DD}$  range: 2.6 to 3.6 V, external power supply for I/Os and the internal regulator. Provided externally through  $V_{DD}$  pins.
- $V_{SSA}$ ,  $V_{DDA}$  range: 2.6 to 3.6 V, external analog power supplies for ADC, reset blocks, RCs and PLL.  $V_{DDA}$  and  $V_{SSA}$  must be connected to  $V_{DD}$  and  $V_{SS}$ , respectively.
- $V_{BAT}$  range: 1.8 to 3.6 V, power supply for RTC, external clock 32 kHz oscillator and backup registers (through power switch) when  $V_{DD}$  is not present.

### 3.4 Boot modes

At startup, boot pins are used to select one of three boot options:

- Boot from main Flash memory (default)
- Boot from system memory
- Boot from on-chip SRAM

In default condition, boot from main Flash memory is selected. The boot loader is located in the internal boot ROM memory (system memory). It is used to reprogram the Flash memory by using USART0 in device mode.



## 3.5 Power saving modes

The MCU supports three kinds of power saving modes to achieve even lower power consumption. They are Sleep mode, Deep-sleep mode, and Standby mode. These operating modes reduce the power consumption and allow the application to achieve the best balance between the CPU operating time, speed and power consumption.

- **Sleep mode**

In sleep mode, only the clock of CPU core is off. All peripherals continue to operate and any interrupt/event can wake up the system.

- **Deep-sleep mode**

In Deep-sleep mode, all clocks in the 1.2V domain are off, and all of the high speed crystal oscillator (IRC8M, HXTAL) and PLL are disabled. Only the contents of SRAM and registers are retained. Any interrupt or wakeup event from EXTI lines can wake up the system from the Deep-sleep mode including the 16 external lines, the RTC alarm, the LVD output, and USB wakeup. When exiting the Deep-sleep mode, the IRC8M is selected as the system clock.

- **Standby mode**

In Standby mode, the whole 1.2V domain is power off, the LDO is shut down, and all of IRC8M, HXTAL and PLL are disabled. The contents of SRAM and registers (except Backup Registers) are lost. There are four wakeup sources for the Standby mode, including the external reset from NRST pin, the RTC alarm, the FWDGT reset, and the rising edge on WKUP pin.

## 3.6 Analog to digital converter (ADC)

- 12-bit SAR ADC's conversion rate is up to 2.6MSPS
- 12-bit, 10-bit, 8-bit or 6-bit configurable resolution
- Hardware oversampling ratio adjustable from 2 to 256x improves resolution to 16-bit
- Input voltage range:  $V_{SSA}$  to  $V_{DDA}$  (2.6 to 3.6 V)
- Temperature sensor

One 12-bit 2.6MSPS multi-channel ADCs are integrated in the device. It has a total of 19 multiplexed channels: 16 external channels, 1 channel for internal temperature sensor ( $V_{SENSE}$ ), 1 channel for internal reference voltage ( $V_{REFINT}$ ) and 1 channel for battery voltage ( $V_{BAT}$ ). The input voltage range is between  $V_{SSA}$  and  $V_{DDA}$ . An on-chip hardware oversampling scheme improves performance while off-loading the related computational burden from the CPU. An analog watchdog block can be used to detect the channels, which are required to remain within a specific threshold window. A configurable channel management block can be used to perform conversions in single, continuous, scan or discontinuous mode to support more advanced use.

The ADC can be triggered from the events generated by the general-purpose level 0 timers (TMx) and the advanced-control timers (TM0 and TM7) with internal connection. The temperature sensor can be used to generate a voltage that varies linearly with temperature. It is internally connected to the ADC\_IN16 input channel which is used to convert the sensor output voltage in a digital value.

## 3.7 DMA

- 7 channel DMA controller
- Peripherals supported: Timers, ADC, SPIs, I<sup>2</sup>Cs, USARTs

The flexible general-purpose DMA controllers provide a hardware method of transferring data between peripherals and/or memory without intervention from the CPU, thereby freeing up bandwidth for other system functions. Three types of access method are supported: peripheral to memory, memory to peripheral, memory to memory

Each channel is connected to fixed hardware DMA requests. The priorities of DMA channel requests are determined by software configuration and hardware channel number. Transfer size of source and destination are independent and configurable.

### 3.8 General-purpose inputs/outputs (GPIOs)

- Up to 55 fast GPIOs, all mappable on 16 external interrupt vectors (EXTI)
- Analog input/output configurable
- Alternate function input/output configurable

There are up to 55 general purpose I/O pins (GPIO) in GD32F330xx, named PA0 ~ PA15 and PB0 ~ PB15, PC0 ~ PC15, PD2, PF0, PF1, PF4-PF7 to implement logic input/output functions. Each of the GPIO ports has related control and configuration registers to satisfy the requirements of specific applications. The external interrupts on the GPIO pins of the device have related control and configuration registers in the External Interrupt Control Unit (EXTI). The GPIO ports are pin-shared with other alternative functions (AFs) to obtain maximum flexibility on the package pins. Each of the GPIO pins can be configured by software as output (push-pull, open-drain or analog), as input (with or without pull-up or pull-down) or as peripheral alternate function. Most of the GPIO pins are shared with digital or analog alternate functions. All GPIOs are high-current capable except for analog inputs.

### 3.9 Timers and PWM generation

- One 16-bit advanced-control timer (TM0), one 32-bit general-purpose timer (TM1) and five 16-bit general-purpose timers (TM2, TM13 ~ TM16)
- Up to 4 independent channels of PWM, output compare or input capture for each general-purpose timer (GPTM) and external trigger input
- 16-bit, motor control PWM advanced-control timer with programmable dead-time generation for output match
- Encoder interface controller with two inputs using quadrature decoder
- 24-bit SysTick timer down counter
- 2 watchdog timers (Independent watchdog and window watchdog)

The advanced-control timer (TM0) can be used as a three-phase PWM multiplexed on 6 channels. It has complementary PWM outputs with programmable dead-time generation. It can also be used as a complete general-purpose timer. The 4 independent channels can be used for input capture, output compare, PWM generation (edge- or center-aligned counting modes) and single pulse mode output. If configured as a general-purpose 16-bit timer, it has the same functions as the TMx timer. It can be synchronized with external signals or to interconnect with other GPTMs together which have the same architecture and features.

The general-purpose timer (GPTM) can be used for a variety of purposes including general time, input signal pulse width measurement or output waveform generation such as a single pulse generation or PWM output, up to 4 independent channels for input capture/output compare. TM1 is based on a 32-bit auto-reload up/downcounter and a 16-bit prescaler. TM3 is based on a 16-bit auto-reload up/downcounter and a 16-bit prescaler. TM13 ~ TM16 is based on a 16-bit auto-reload upcounter and a 16-bit prescaler. The GPTM also supports an encoder interface with two inputs using quadrature decoder.

The GD32F330xx have two watchdog peripherals, free watchdog and window watchdog. They offer a combination of high safety level, flexibility of use and timing accuracy.

The independent watchdog timer includes a 12-bit down-counting counter and a 8-bit prescaler. It is clocked from an independent 40 kHz internal RC and as it operates independently of the main clock, it can operate in deep-sleep and standby modes. It can be used either as a watchdog to reset the device when a problem occurs, or as a free-running timer for application timeout management.

The window watchdog is based on a 7-bit down counter that can be set as free-running. It can be used as a watchdog to reset the device when a problem occurs. It is clocked from the main clock. It has an early warning interrupt capability and the counter can be frozen in debug mode.

The SysTick timer is dedicated for OS, but could also be used as a standard down counter. It features:

- A 24-bit down counter
- Auto reload capability
- Maskable system interrupt generation when the counter reaches 0
- Programmable clock source

### 3.10 Real time clock (RTC)

- Independent binary-coded decimal (BCD) format timer/counter with five 32-bit backup registers.
- Calendar with subsecond, seconds, minutes, hours, week day, date, year and month automatically correction
- Alarm function with wake up from deep-sleep and standby mode capability
- On-the-fly correction for synchronization with master clock. Digital calibration with 0.954 ppm resolution for compensation of quartz crystal inaccuracy.

The real time clock is an independent timer which provides a set of continuously running counters in backup registers to provide a real calendar function, and provides an alarm interrupt or an expected interrupt. It is not reset by a system or power reset, or when the device wakes up from standby mode. A 20-bit prescaler is used for the time base clock and is by default configured to generate a time base of 1 second from a clock at 32.768 kHz from external crystal oscillator.

### 3.11 Inter-integrated circuit (I2C)

- Up to two I2C bus interfaces can support both master and slave mode with a frequency up to 1 MHz (Fast mode plus)
- Provide arbitration function, optional PEC (packet error checking) generation and checking
- Supports 7-bit and 10-bit addressing mode and general call addressing mode

The I2C interface is an internal circuit allowing communication with an external I2C interface which is an industry standard two line serial interface used for connection to external hardware. These two serial lines are known as a serial data line (SDA) and a serial clock line (SCL). The I2C module provides two data transfer rates: 100 kHz of standard mode, 400 kHz of the fast mode and 1 MHz of the fast mode plus. The I2C module also has an arbitration detect function to prevent the situation where more than one master attempts to transmit data to the I2C bus at the same time. A CRC-8 calculator is also provided in I2C interface to perform packet error checking for I2C data.

### 3.12 Serial peripheral interface (SPI)

- Up to two SPI interfaces with a frequency of up to 30 MHz
- Support both master and slave mode
- Hardware CRC calculation and transmit automatic CRC error checking

The SPI interface uses 4 pins, among which are the serial data input and output lines (MISO & MOSI), the clock line (SCK) and the slave select line (NSS). Both SPIs can be served by the DMA controller. The SPI interface may be used for a variety of purposes, including simplex synchronous transfers on two lines with a possible bidirectional data line or reliable communication using CRC checking.

### 3.13 Universal synchronous asynchronous receiver transmitter (USART)

- Up to two USARTs with operating frequency up to 10.5 Mbits/s
- Supports both asynchronous and clocked synchronous serial communication modes
- IrDA SIR encoder and decoder support
- LIN break generation and detection
- ISO 7816-3 compliant smart card interface

The USART (USART0, USART1) are used to translate data between parallel and serial interfaces, provides a flexible full duplex data exchange using synchronous or asynchronous transfer. It is also commonly used for RS-232 standard communication. The USART includes a programmable baud rate generator which is capable of dividing the system clock to produce a dedicated clock for the USART transmitter and receiver. The USART also supports DMA

function for high speed data communication.

### 3.14 Debug mode

- Serial wire JTAG debug port (SWJ-DP)

The ARM® SWJ-DP Interface is embedded and is a combined JTAG and serial wire debug port that enables either a serial wire debug or a JTAG probe to be connected to the target.

### 3.15 Package and operation temperature

- LQFP64 (GD32F330Rx), LQFP48 (GD32F330Cx), QFN32 (GD32F330Kx), QFN28 (GD32F330Gx) and TSSOP20 (GD32F330Fx)
- Operation temperature range: -40°C to +85°C (industrial level)

## 4 Electrical characteristics

### 4.1 Absolute maximum ratings

The maximum ratings are the limits to which the device can be subjected without permanently damaging the device. Note that the device is not guaranteed to operate properly at the maximum ratings. Exposure to the absolute maximum rating conditions for extended periods may affect device reliability.

**Table 8. Absolute maximum ratings**

Symbol	Parameter	Min	Max	Unit
$V_{DD}$	External voltage range	$V_{SS} - 0.3$	$V_{SS} + 3.6$	V
$V_{DDA}$	External analog supply voltage	$V_{SSA} - 0.3$	$V_{SSA} + 3.6$	V
$V_{BAT}$	External battery supply voltage	$V_{SS} - 0.3$	$V_{SS} + 3.6$	V
$V_{IN}$	Input voltage on 5V tolerant pin	$V_{SS} - 0.3$	$V_{DD} + 4.0$	V
	Input voltage on other I/O	$V_{SS} - 0.3$	4.0	V
$ \Delta V_{DDx} $	Variations between different VDD power pins	—	50	mV
$ V_{SSx} - V_{SS} $	Variations between different ground pins	—	50	mV
$I_{IO}$	Maximum current for GPIO pins	—	25	mA
$T_A$	Operating temperature range	-40	+85	°C
$T_{STG}$	Storage temperature range	-55	+150	°C
$T_J$	Maximum junction temperature	—	125	°C

### 4.2 Recommended DC characteristics

**Table 9. DC operating conditions**

Symbol	Parameter	Conditions	Min	Typ	Max	Unit
$V_{DD}$	Supply voltage	—	2.6	3.3	3.6	V
$V_{DDA}$	Analog supply voltage	Same as $V_{DD}$	2.6	3.3	3.6	V
$V_{BAT}$	Battery supply voltage	—	1.8	—	3.6	V

## 4.3 Power consumption

The power measurements specified in the tables represent that code with data executing from on-chip Flash with the following specifications.

**Table 10. Power consumption characteristics**

Symbol	Parameter	Conditions	Min	Typ	Max	Unit
I <sub>DD</sub>	Supply current (Run mode)	V <sub>DD</sub> =V <sub>DDA</sub> =3.3V, HSE=8MHz, System clock=84 MHz, All peripherals enabled	—	19.86	—	mA
		V <sub>DD</sub> =V <sub>DDA</sub> =3.3V, HSE=8MHz, System clock =84 MHz, All peripherals disabled	—	15.14	—	mA
		V <sub>DD</sub> =V <sub>DDA</sub> =3.3V, HSE=8MHz, System clock =48 MHz, All peripherals enabled	—	11.99	—	mA
		V <sub>DD</sub> =V <sub>DDA</sub> =3.3V, HSE=8MHz, System Clock =48 MHz, All peripherals disabled	—	9.30	—	mA
	Supply current (Sleep mode)	V <sub>DD</sub> =V <sub>DDA</sub> =3.3V, HSE=8MHz, CPU clock off, System clock =84 MHz, All peripherals enabled	—	10.60	—	mA
		V <sub>DD</sub> =V <sub>DDA</sub> =3.3V, HSE=8MHz, CPU clock off, System clock =84 MHz, All peripherals disabled	—	5.24	—	mA
	Supply current (Deep-Sleep mode)	V <sub>DD</sub> =V <sub>DDA</sub> =3.3V, Regulator in run mode, LSI on, RTC on, All GPIOs analog mode	—	117.06	—	μA
		V <sub>DD</sub> =V <sub>DDA</sub> =3.3V, Regulator in low power under drive, LSI on, RTC on, All GPIOs analog mode	—	91.98	—	μA
	Supply current (Standby mode)	V <sub>DD</sub> =V <sub>DDA</sub> =3.3V, LSE off, LSI on, RTC on	—	7.83	—	μA
		V <sub>DD</sub> =V <sub>DDA</sub> =3.3V, LSE off, LSI on, RTC off	—	7.54	—	μA
		V <sub>DD</sub> =V <sub>DDA</sub> =3.3V, LSE off, LSI off, RTC off	—	6.85	—	μA
	I <sub>BAT</sub>	Battery supply current	V <sub>DD</sub> not available, V <sub>BAT</sub> =3.6 V, LSE on with external crystal, RTC on, Higher driving	—	1.74	—
V <sub>DD</sub> not available, V <sub>BAT</sub> =3.3 V, LSE on with external crystal, RTC on, Higher driving			—	1.59	—	μA
V <sub>DD</sub> not available, V <sub>BAT</sub> =2.6 V, LSE on with external crystal, RTC on, Higher driving			—	1.38	—	μA
V <sub>DD</sub> not available, V <sub>BAT</sub> =3.6 V, LSE on with external crystal, RTC on, Lower driving			—	1.07	—	μA
V <sub>DD</sub> not available, V <sub>BAT</sub> =3.3 V, LSE on with external crystal, RTC on, Lower driving			—	0.92	—	μA
V <sub>DD</sub> not available, V <sub>BAT</sub> =2.6 V, LSE on with external crystal, RTC on, Lower driving			—	0.72	—	μA



## 4.4 EMC characteristics

EMS (electromagnetic susceptibility) includes ESD (Electrostatic discharge, positive and negative) and FTB (Burst of Fast Transient voltage, positive and negative) testing result is given in the following table, based on the EMS levels and classes compliant with IEC 61000 series standard.

**Table 11. EMS characteristics**

Symbol	Parameter	Conditions	Level/Class
V <sub>ESD</sub>	Voltage applied to all device pins to induce a functional disturbance	VDD = 3.3 V, TA = +25 °C conforms to IEC 61000-4-2	3B
V <sub>FTB</sub>	Fast transient voltage burst applied to induce a functional disturbance through 100 pF on V <sub>DD</sub> and V <sub>SS</sub> pins	VDD = 3.3 V, TA = +25 °C conforms to IEC 61000-4-4	4A

EMI (Electromagnetic Interference) emission testing result is given in the following table, compliant with IEC 61967-2 standard which specifies the test board and the pin loading.

**Table 12. EMI characteristics**

Symbol	Parameter	Conditions	Tested frequency band	Conditions		Unit
				48M	72M	
S <sub>EMI</sub>	Peak level	VDD = 3.3 V, TA = +25 °C, compliant with IEC 61967-2	0.1 to 2 MHz	<0	<0	dBμV
			2 to 30 MHz	-3.7	-2.8	
			30 to 130 MHz	-6.5	-8	
			130 MHz to 1GHz	-7	-7	

## 4.5 Power supply supervisor characteristics

**Table 13 Power supply supervisor characteristics**

Symbol	Parameter	Conditions	Min	Typ	Max	Unit
V <sub>POR</sub>	Power on reset threshold	—	2.30	2.40	2.48	V
V <sub>PDR</sub>	Power down reset threshold		1.72	1.80	1.88	V
V <sub>HYST</sub>	PDR hysteresis		—	0.6	—	V
T <sub>RSTTEMP</sub>	Reset temporization		—	2	—	ms

## 4.6 Electrical sensitivity

The device is strained in order to determine its performance in terms of electrical sensitivity. Electrostatic discharges (ESD) are applied directly to the pins of the sample. Static latch-up (LU) test is based on the two measurement methods.

**Table 14. ESD characteristics**

Symbol	Parameter	Conditions	Min	Typ	Max	Unit
$V_{ESD(HBM)}$	Electrostatic discharge voltage (human body model)	$T_A=25\text{ }^\circ\text{C}$ ; JESD22-A114	—	—	7000	V
$V_{ESD(CDM)}$	Electrostatic discharge voltage (charge device model)	$T_A=25\text{ }^\circ\text{C}$ ; JESD22-C101	—	—	2000	V

**Table 15. Static latch-up characteristics**

Symbol	Parameter	Conditions	Min	Typ	Max	Unit
LU	I-test	$T_A=25\text{ }^\circ\text{C}$ ; JESD78	—	—	$\pm 200$	mA
	$V_{\text{supply over voltage}}$		—	—	5.4	V

## 4.7 External clock characteristics

**Table 16. High speed external clock (HXTAL) generated from a crystal/ceramic characteristics**

Symbol	Parameter	Conditions	Min	Typ	Max	Unit
$f_{\text{HXTAL}}$	High speed external clock (HXTAL) frequency	$V_{\text{DD}}=3.3\text{V}$	4	8	32	MHz
$C_{\text{HXTAL}}$	Recommended load capacitance on OSC_IN and OSC_OUT	—	—	20	30	pF
$D_{\text{HXTAL}}$	HXTAL oscillator duty cycle	—	30	50	70	%
$I_{\text{DDHXTAL}}$	HXTAL oscillator operating current	$V_{\text{DD}}=3.3\text{V}$ , $T_{\text{A}}=25^{\circ}\text{C}$	—	1.0	—	mA
$t_{\text{SUHXTAL}}$	HXTAL oscillator startup time	$V_{\text{DD}}=3.3\text{V}$ , $T_{\text{A}}=25^{\circ}\text{C}$	—	2	—	ms

**Table 17. Low speed external clock (LXTAL) generated from a crystal/ceramic characteristics**

Symbol	Parameter	Conditions	Min	Typ	Max	Unit
$f_{\text{LXTAL}}$	Low Speed External oscillator (LXTAL) frequency	$V_{\text{DD}}=V_{\text{BAT}}=3.3\text{V}$	—	32.768	—	KHz
$C_{\text{LXTAL}}$	Recommended load capacitance on OSC32_IN and OSC32_OUT	—	—	—	15	pF
$D_{\text{LXTAL}}$	LXTAL oscillator duty cycle	—	30	50	70	%
$I_{\text{DDLXTAL}}$	LXTAL oscillator operating current	Low Drive	—	0.7	—	$\mu\text{A}$
		High Drive	—	1.3	—	
$t_{\text{SULXTAL}}$	LXTAL oscillator startup time	$V_{\text{DD}}=V_{\text{BAT}}=3.3\text{V}$	—	2	—	s

## 4.8 Internal clock characteristics

**Table 18. High speed internal clock (IRC8M) characteristics**

Symbol	Parameter	Conditions	Min	Typ	Max	Unit
$f_{\text{IRC8M}}$	High Speed Internal Oscillator (IRC8M) frequency	$V_{\text{DD}}=3.3\text{V}$	—	8	—	MHz
$\text{ACC}_{\text{IRC8M}}$	IRC8M oscillator Frequency accuracy, Factory-trimmed	$V_{\text{DD}}=3.3\text{V}$ , $T_{\text{A}}=-40^{\circ}\text{C} \sim +105^{\circ}\text{C}$	-4.0	—	+5.0	%
		$V_{\text{DD}}=3.3\text{V}$ , $T_{\text{A}}=0^{\circ}\text{C} \sim +85^{\circ}\text{C}$	-2.0	—	+2.0	%
		$V_{\text{DD}}=3.3\text{V}$ , $T_{\text{A}}=25^{\circ}\text{C}$	-1.0	—	+1.0	%
	IRC8M oscillator Frequency accuracy, User trimming step	—	—	0.5	—	%
$D_{\text{IRC8M}}$	IRC8M oscillator duty cycle	$V_{\text{DD}}=3.3\text{V}$ , $f_{\text{IRC8M}}=8\text{MHz}$	45	50	55	%
$I_{\text{DDIRC8M}}$	IRC8M oscillator operating	$V_{\text{DD}}=3.3\text{V}$ , $f_{\text{IRC8M}}=8\text{MHz}$	—	66	80	$\mu\text{A}$

Symbol	Parameter	Conditions	Min	Typ	Max	Unit
	current					
t <sub>SUIRC8M</sub>	IRC8M oscillator startup time	V <sub>DD</sub> =3.3V, f <sub>IRC8M</sub> =8MHz	—	1.8	2.5	us

**Table 19. High speed internal clock (IRC48M) characteristics**

Symbol	Parameter	Conditions	Min	Typ	Max	Unit
f <sub>IRC48M</sub>	High Speed Internal Oscillator (IRC48M) frequency	V <sub>DD</sub> =3.3V	—	48	—	MHz
ACC <sub>IRC48M</sub>	IRC48M oscillator Frequency accuracy, Factory-trimmed	V <sub>DD</sub> =3.3V, T <sub>A</sub> =-40°C ~+105°C	-4.0	—	+5.0	%
		V <sub>DD</sub> =3.3V, T <sub>A</sub> =0°C ~ +85°C	-3.0	—	+3.0	%
		V <sub>DD</sub> =3.3V, T <sub>A</sub> =25°C	-2.0	—	+2.0	%
	IRC48M oscillator Frequency accuracy, User trimming step	—	—	0.12	—	%
D <sub>IRC48M</sub>	IRC48M oscillator duty cycle	V <sub>DD</sub> =3.3V, f <sub>IRC48M</sub> =16MHz	45	50	55	%
I <sub>DDIRC48M</sub>	IRC48M oscillator operating current	V <sub>DD</sub> =3.3V, f <sub>IRC48M</sub> =16MHz	—	240	300	μA
t <sub>SUIRC48M</sub>	IRC48M oscillator startup time	V <sub>DD</sub> =3.3V, f <sub>IRC48M</sub> =16MHz	—	2.5	4	us

**Table 20. Low speed internal clock (IRC40K) characteristics**

Symbol	Parameter	Conditions	Min	Typ	Max	Unit
f <sub>IRC40K</sub>	Low Speed Internal oscillator (IRC40K) frequency	V <sub>DD</sub> =V <sub>BAT</sub> =3.3V, T <sub>A</sub> =-40°C ~ +85°C	20	40	45	KHz
I <sub>DDIRC40K</sub>	IRC40K oscillator operating current	V <sub>DD</sub> =V <sub>BAT</sub> =3.3V, T <sub>A</sub> =25°C	—	0.4	0.6	μA
t <sub>SUIRC40K</sub>	IRC40K oscillator startup time	V <sub>DD</sub> =V <sub>BAT</sub> =3.3V, T <sub>A</sub> =25°C	—	110	130	μs

## 4.9 PLL characteristics

**Table 21. PLL characteristics**

Symbol	Parameter	Conditions	Min	Typ	Max	Unit
$f_{PLLIN}$	PLL input clock frequency	—	1	—	25	MHz
$f_{PLLOUT}$	PLL output clock frequency	—	16	—	84	MHz
$t_{LOCK}$	PLL lock time	—	—	—	300	$\mu$ s
$I_{DD}$	Current consumption on VDD	VCO freq=84MHz	—	160	—	$\mu$ A
$I_{DDA}$	Current consumption on VDDA	VCO freq=84MHz	—	300	—	$\mu$ A
Jitter <sub>PLL</sub>	Cycle to cycle Jitter	System clock	—	300	—	ps

## 4.10 Memory characteristics

**Table 22. Flash memory characteristics**

Symbol	Parameter	Conditions	Min	Typ	Max	Unit
PE <sub>CYC</sub>	Number of guaranteed program /erase cycles before failure (Endurance)	$T_A = -40^{\circ}\text{C} \sim +85^{\circ}\text{C}$	100	—	—	kcycles
$t_{RET}$	Data retention time	$T_A = 125^{\circ}\text{C}$	20	—	—	years
$t_{PROG}$	Word programming time	$T_A = -40^{\circ}\text{C} \sim +85^{\circ}\text{C}$	200	—	400	$\mu$ s
$t_{ERASE}$	Page erase time	$T_A = -40^{\circ}\text{C} \sim +85^{\circ}\text{C}$	60	100	450	ms
$t_{MERASE}$	Mass erase time	$T_A = -40^{\circ}\text{C} \sim +85^{\circ}\text{C}$	3.2	—	9.6	s

## 4.11 GPIO characteristics

**Table 23. I/O port characteristics**

Symbol	Parameter		Conditions	Min	Typ	Max	Unit
V <sub>IL</sub>	Standard IO Low level input voltage		V <sub>DD</sub> =2.6V	—	—	1.03	V
			V <sub>DD</sub> =3.3V	—	—	1.31	
			V <sub>DD</sub> =3.6V	—	—	1.41	
	High Voltage tolerant IO Low level input voltage		V <sub>DD</sub> =2.6V	—	—	1.02	V
			V <sub>DD</sub> =3.3V	—	—	1.36	
			V <sub>DD</sub> =3.6V	—	—	1.41	
V <sub>IH</sub>	Standard IO High level input voltage		V <sub>DD</sub> =2.6V	1.69	—	—	V
			V <sub>DD</sub> =3.3V	1.99	—	—	
			V <sub>DD</sub> =3.6V	2.11	—	—	
	High Voltage tolerant IO High level input voltage		V <sub>DD</sub> =2.6V	1.68	—	—	V
			V <sub>DD</sub> =3.3V	1.99	—	—	
			V <sub>DD</sub> =3.6V	2.11	—	—	
V <sub>OL</sub>	Low level output voltage		V <sub>DD</sub> =2.6V, I <sub>IO</sub> =8mA	—	—	0.21	V
			V <sub>DD</sub> =3.3V, I <sub>IO</sub> =8mA	—	—	0.19	
			V <sub>DD</sub> =3.6V, I <sub>IO</sub> =8mA	—	—	0.18	
			V <sub>DD</sub> =2.6V, I <sub>IO</sub> =20mA	—	—	0.54	
			V <sub>DD</sub> =3.3V, I <sub>IO</sub> =20mA	—	—	0.47	
			V <sub>DD</sub> =3.6V, I <sub>IO</sub> =20mA	—	—	0.45	
V <sub>OH</sub>	High level output voltage		V <sub>DD</sub> =2.6V, I <sub>IO</sub> =8mA	2.40	—	—	V
			V <sub>DD</sub> =3.3V, I <sub>IO</sub> =8mA	3.10	—	—	
			V <sub>DD</sub> =3.6V, I <sub>IO</sub> =8mA	3.40	—	—	
			V <sub>DD</sub> =2.6V, I <sub>IO</sub> =20mA	1.95	—	—	
			V <sub>DD</sub> =3.3V, I <sub>IO</sub> =20mA	2.73	—	—	
			V <sub>DD</sub> =3.6V, I <sub>IO</sub> =20mA	3.07	—	—	
R <sub>PU</sub>	Internal pull-up resistor	All pins	V <sub>IN</sub> =V <sub>SS</sub>	30	40	50	kΩ
		PA10	—	7.5	10	13.5	
R <sub>PD</sub>	Internal pull-down resistor	All pins	V <sub>IN</sub> =V <sub>DD</sub>	30	40	50	kΩ
		PA10	—	7.5	10	13.5	

## 4.12 ADC characteristics

**Table 24. ADC characteristics**

Symbol	Parameter	Conditions	Min	Typ	Max	Unit
V <sub>DDA</sub>	Operating voltage	—	2.6	3.3	3.6	V
V <sub>ADCIN</sub>	ADC input voltage range	—	0	—	V <sub>REF+</sub>	V
f <sub>ADC</sub>	ADC clock	—	0.1	—	40	MHz
f <sub>s</sub>	Sampling rate	12-bit	0.007	—	2.86	MSPS
		10-bit	0.008	—	3.33	
		8-bit	0.01	—	4.00	
		6-bit	0.012	—	5.00	
V <sub>IN</sub>	Analog input voltage	16 external; 3 internal (including the battery voltage channel)	0	—	V <sub>DDA</sub>	V
V <sub>REF+</sub>	Positive Reference Voltage	—	—	V <sub>DDA</sub>	—	V
V <sub>REF-</sub>	Negative Reference Voltage	—	—	0	—	V
R <sub>AIN</sub>	External input impedance	See <b>Equation 2</b>	—	—	32.9	kΩ
R <sub>ADC</sub>	Input sampling switch resistance	—	—	—	0.55	kΩ
C <sub>ADC</sub>	Input sampling capacitance	No pin/pad capacitance included	—	—	5.5	pF
t <sub>CAL</sub>	Calibration time	f <sub>ADC</sub> =40MHz	—	3.275	—	μs
t <sub>s</sub>	Sampling time	f <sub>ADC</sub> =40MHz	0.0375	—	5.99	μs
t <sub>CONV</sub>	Total conversion time (including sampling time)	12-bit	—	14	—	1/ f <sub>ADC</sub>
		10-bit	—	12	—	
		8-bit	—	10	—	
		6-bit	—	8	—	
t <sub>SU</sub>	Startup time	—	—	—	1	μs

**Equation 2:** R<sub>AIN</sub> max formula 
$$R_{AIN} < \frac{T_s}{f_{ADC} \cdot C_{ADC} \cdot \ln(2^{N+2})} - R_{ADC}$$

The formula above (Equation 2) is used to determine the maximum external impedance allowed for an error below 1/4 of LSB. Here N=12 (from 12-bit resolution).

**Table 25. ADC R<sub>AIN</sub> max for f<sub>ADC</sub>=40MHz**

T <sub>s</sub> (cycles)	t <sub>s</sub> (us)	R <sub>AIN</sub> max (KΩ)
1.5	0.0375	0.15
7.5	0.1875	2.96
13.5	0.3375	5.77
28.5	0.7125	12.8
41.5	1.0375	18.9
55.5	1.3875	25.4
71.5	1.7875	32.9
239.5	5.9875	N/A

Note: Guaranteed by design, not tested in production.

**Table 26. ADC dynamic accuracy at  $f_{ADC} = 28$  MHz**

Symbol	Parameter	Test conditions	Min	Typ	Max	Unit
ENOB	Effective number of bits	$f_{ADC}=28\text{MHz}$ $V_{DDA}=V_{REFP}=2.6\text{V}$ Input Frequency=20KHz Temperature=25°C	10.5	10.6	—	bits
SNDR	Signal-to-noise and distortion ratio		65	65.6	—	
SNR	Signal-to-noise ratio		65.5	66	—	
THD	Total harmonic distortion		-74	-76	—	

**Table 27. ADC dynamic accuracy at  $f_{ADC} = 30$  MHz**

Symbol	Parameter	Test conditions	Min	Typ	Max	Unit
ENOB	Effective number of bits	$f_{ADC}=30\text{MHz}$ $V_{DDA}=V_{REFP}=3.3\text{V}$ Input Frequency=20KHz Temperature=25°C	10.7	10.8	—	bits
SNDR	Signal-to-noise and distortion ratio		66.2	65.8	—	
SNR	Signal-to-noise ratio		66.8	67.4	—	
THD	Total harmonic distortion		-71	-75	—	

**Table 28. ADC dynamic accuracy at  $f_{ADC} = 36$  MHz**

Symbol	Parameter	Test conditions	Min	Typ	Max	Unit
ENOB	Effective number of bits	$f_{ADC}=36\text{MHz}$ $V_{DDA}=V_{REFP}=3.3\text{V}$ Input Frequency=20KHz Temperature=25°C	10.3	10.4	—	bits
SNDR	Signal-to-noise and distortion ratio		63.8	64.4	—	
SNR	Signal-to-noise ratio		64.2	65	—	
THD	Total harmonic distortion		-70	-72	—	

**Table 29. ADC static accuracy at  $f_{ADC} = 14$  MHz**

Symbol	Parameter	Test conditions	Typ	Max	Unit
Offset	Offset error	$f_{ADC}=14\text{MHz}$ $V_{DDA}=V_{REFP}=3.3\text{V}$	±2	±3	LSB
DNL	Differential linearity error		±0.9	±1.2	
INL	Integral linearity error		±1.1	±1.5	



## 4.13 I2C characteristics

Table 30. I2C characteristics

Symbol	Parameter	Conditions	Standard mode		Fast mode		Unit
			Min	Max	Min	Max	
f <sub>SCL</sub>	SCL clock frequency	—	0	100	0	1000	KHz
TSI <sub>L(H)</sub>	SCL clock high time	—	4.0	—	0.6	—	ns
TSI <sub>L(L)</sub>	SCL clock low time	—	4.7	—	1.3	—	ns

## 4.14 SPI characteristics

Table 31. SPI characteristics

Symbol	Parameter	Conditions	Min	Typ	Max	Unit
f <sub>SCK</sub>	SCK clock frequency	—	—	—	30	MHz
TSI <sub>K(H)</sub>	SCK clock high time	—	16	—	—	ns
TSI <sub>K(L)</sub>	SCK clock low time	—	16	—	—	ns
<b>SPI master mode</b>						
t <sub>V(MO)</sub>	Data output valid time	—	—	—	25	ns
t <sub>H(MO)</sub>	Data output hold time	—	2	—	—	ns
t <sub>SU(MI)</sub>	Data input setup time	—	5	—	—	ns
t <sub>H(MI)</sub>	Data input hold time	—	5	—	—	ns
<b>SPI slave mode</b>						
t <sub>SU(NSS)</sub>	NSS enable setup time	f <sub>PCLK</sub> =42MHz	74	—	—	ns
t <sub>H(NSS)</sub>	NSS enable hold time	f <sub>PCLK</sub> =42MHz	37	—	—	ns
t <sub>A(SO)</sub>	Data output access time	f <sub>PCLK</sub> =42MHz	0	—	55	ns
t <sub>DIS(SO)</sub>	Data output disable time	—	3	—	10	ns
t <sub>V(SO)</sub>	Data output valid time	—	—	—	25	ns
t <sub>H(SO)</sub>	Data output hold time	—	15	—	—	ns
t <sub>SU(SI)</sub>	Data input setup time	—	5	—	—	ns
t <sub>H(SI)</sub>	Data input hold time	—	4	—	—	ns

## 4.15 USART characteristics

Table 32. USART characteristics

Symbol	Parameter	Conditions	Min	Typ	Max	Unit
f <sub>SCK</sub>	SCK clock frequency	—	—	—	84	MHz
TSI <sub>K(H)</sub>	SCK clock high time	—	5.5	—	—	ns
TSI <sub>K(L)</sub>	SCK clock low time	—	5.5	—	—	ns

## 5 Package information

### 5.1 TSSOP package outline dimensions

Figure 9. TSSOP package outline

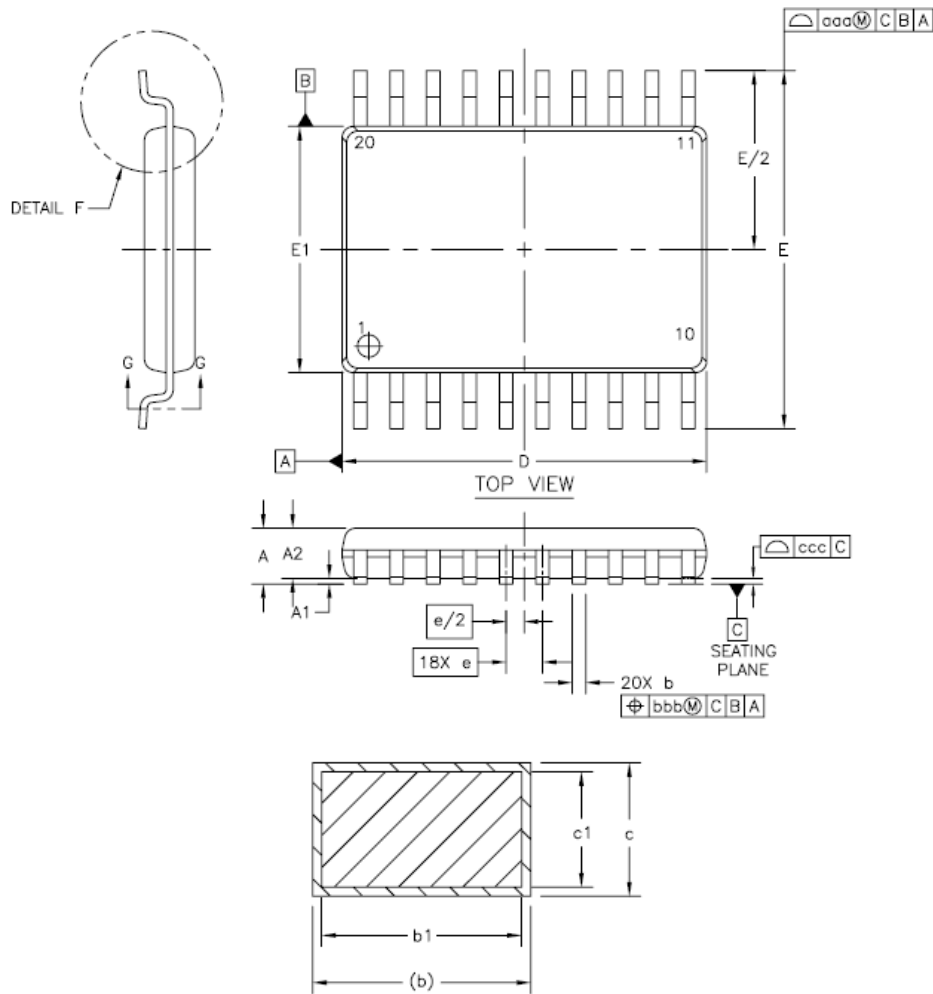
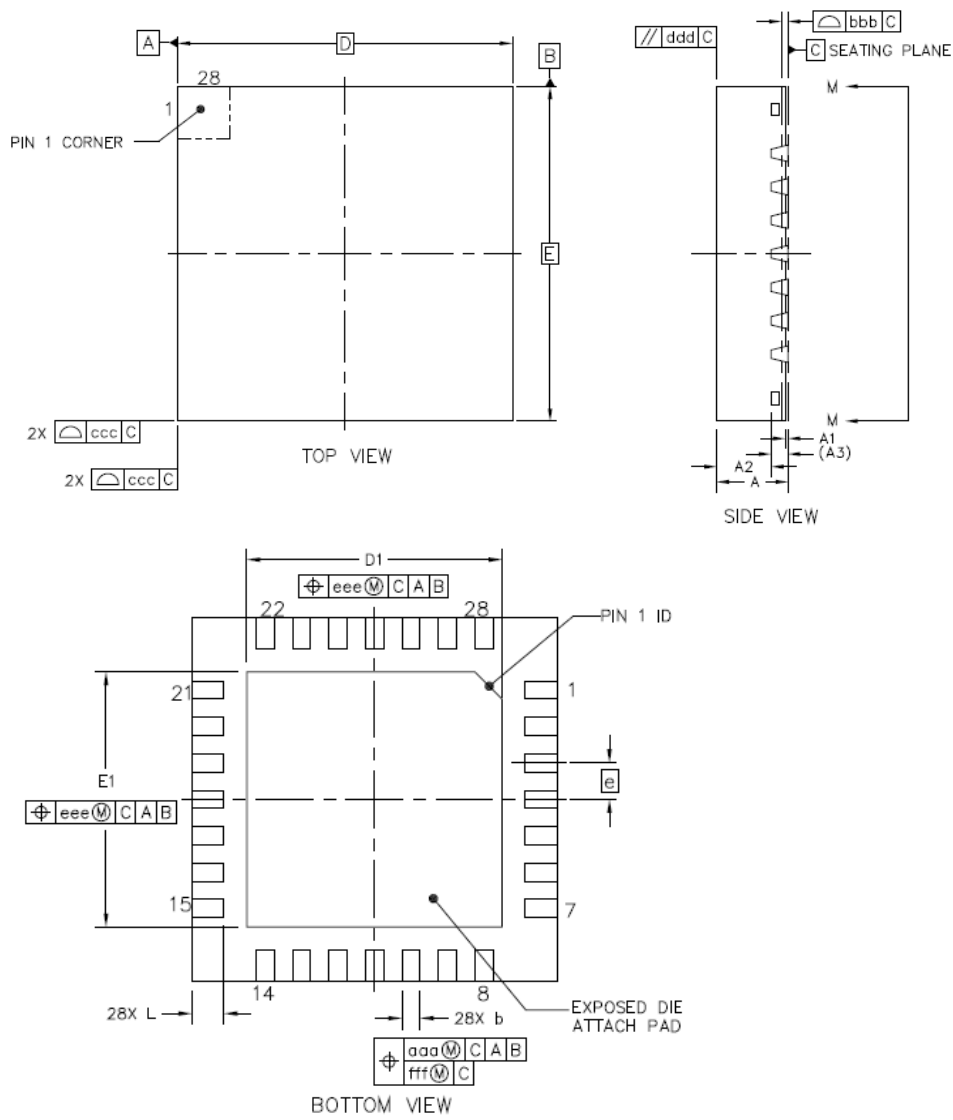

Table 33. TSSOP20 package dimensions

Symbol	Dimensions (mm)			Symbol	Dimensions (mm)		
	Min	Typ	Max		Min	Typ	Max
A	-	-	1.2	c1	0.09	-	0.16
A1	0.05	-	1.15	D	6.4	6.5	6.6
A2	0.80	1.00	1.05	E1	4.3	4.4	4.5
b	0.19	-	0.30	E	6.40		
B1	0.19	0.22	0.25	e	0.65		
c	0.09	-	0.20	L	0.45	0.6	0.75

## 5.2 QFN package outline dimensions

Figure 10. QFN package outline



**Table 34. QFN package dimensions**

Symbol	QFN28		
	Min	Typ	Max
A	0.8	0.85	0.9
A1	0	0.035	0.05
A2	-	0.65	0.67
A3	-	0.203	-
D	-	4.0	-
E	-	4.0	-
D1	2.7	2.8	2.9
E1	2.7	2.8	2.9
L	0.25	0.35	0.45
e	0.4		
b	0.15	0.2	0.25

Symbol	QFN32		
	Min	Typ	Max
A	0.8	0.85	0.9
A1	0	0.035	0.05
A2	-	0.65	0.67
A3	-	0.203	-
D	-	5.0	-
E	-	5.0	-
D1	3.4	3.5	3.6
E1	3.4	3.5	3.6
L	0.3	0.4	0.5
e	0.5		
b	0.2	0.25	0.3

(Original dimensions are in millimeters)



**Table 35. LQFP package dimensions**

Symbol	LQFP48		
	Min	Typ	Max
A	-	-	1.20
A1	0.05	-	0.15
A2	0.95	1.00	1.05
D	-	9.00	-
D1	-	7.00	-
E	-	9.00	-
E1	-	7.00	-
R1	0.08	-	-
R2	0.08	-	0.20
$\theta$	0°	3.5°	7°
$\theta_1$	0°	-	-
$\theta_2$	11°	12°	13°
$\theta_3$	11°	12°	13°
c	0.09	-	0.20
L	0.45	0.60	0.75
L1	-	1.00	-
S	0.20	-	-
b	0.17	0.22	0.27
e	-	0.50	-
D2	-	5.50	-
E2	-	5.50	-
aaa	0.20		
bbb	0.20		
ccc	0.08		

Symbol	LQFP64		
	Min	Typ	Max
A	-	-	1.60
A1	0.05	-	0.15
A2	1.35	1.40	1.45
D	-	12.00	-
D1	-	10.00	-
E	-	12.00	-
E1	-	10.00	-
R1	0.08	-	-
R2	0.08	-	0.20
$\theta$	0°	3.5°	7°
$\theta_1$	0°	-	-
$\theta_2$	11°	12°	13°
$\theta_3$	11°	12°	13°
c	0.09	-	0.20
L	0.45	0.60	0.75
L1	-	1.00	-
S	0.20	-	-
b	0.17	0.20	0.27
e	-	0.50	-
D2	-	7.50	-
E2	-	7.50	-
aaa	0.20		
bbb	0.20		
ccc	0.08		

(Original dimensions are in millimeters)

## 6 Ordering Information

**Table 36. Part ordering code for GD32F330xx devices**

Ordering code	Flash (KB)	Package	Package type	Temperature operating range
GD32F330F4P6	16	TSSOP20	Green	Industrial -40°C to +85°C
GD32F330F6P6	32	TSSOP20	Green	Industrial -40°C to +85°C
GD32F330F8P6	64	TSSOP20	Green	Industrial -40°C to +85°C
GD32F330G4U6	16	QFN28	Green	Industrial -40°C to +85°C
GD32F330G6U6	32	QFN28	Green	Industrial -40°C to +85°C
GD32F330G8U6	64	QFN28	Green	Industrial -40°C to +85°C
GD32F330K4U6	16	QFN32	Green	Industrial -40°C to +85°C
GD32F330K6U6	32	QFN32	Green	Industrial -40°C to +85°C
GD32F330K8U6	64	QFN32	Green	Industrial -40°C to +85°C
GD32F330C4T6	16	LQFP48	Green	Industrial -40°C to +85°C
GD32F330C6T6	32	LQFP48	Green	Industrial -40°C to +85°C
GD32F330C8T6	64	LQFP48	Green	Industrial -40°C to +85°C
GD32F330CBT6	128	LQFP48	Green	Industrial -40°C to +85°C
GD32F330R8T6	64	LQFP64	Green	Industrial -40°C to +85°C
GD32F330RBT6	128	LQFP64	Green	Industrial -40°C to +85°C

## 7 Revision History

Table 37. Revision history

Revision No.	Description	Date
1.0	Initial Release	Jun.6, 2017
1.1	Characteristics values updated in <b>Table 10. Power consumption characteristics</b>	Jun.20, 2017