



Application Note: AN_SY7066/SY7066A

1.8V Minimum Input and 5.5V Maximum Output 6A Peak Current Synchronous Boost with Output Disconnect

General Description

SY7066/SY7066A is a high efficiency synchronous boost regulator that converts down to 1.8V input and up to 5.5V output voltage. It adopts NMOS for the main switch and PMOS for the synchronous switch. It can disconnect the output from input during the shutdown mode.

Ordering Information

SY7066 □(□□)□
 □ Temperature Code
 □ Package Code
 □ Optional Spec Code

Ordering Number	Package type	Note
SY7066QMC	QFN2X2-10	----
SY7066AQMC	QFN2X2-10	----

Features

- 1.8V Minimum input voltage
- Adjustable output voltage from 2.5V to 5.5V
- 6A peak current limit
- Input under voltage lockout
- Load disconnect during shutdown
- Output over voltage protection
- Input battery voltage monitor
- Low $R_{DS(ON)}$ (main switch/synchronous switch) at 5.0V output: 20/40mohm
- Automatic output discharge at shutdown:
 - o SY7066: Auto output discharge function
 - o SY7066A: No output discharge function
- Compact package: QFN2x2-10

Applications

- All Single Cell Li or Dual Cell Battery Operated Products as MP-3 Player, PDAs, and Other Portable Equipment.

Typical Applications

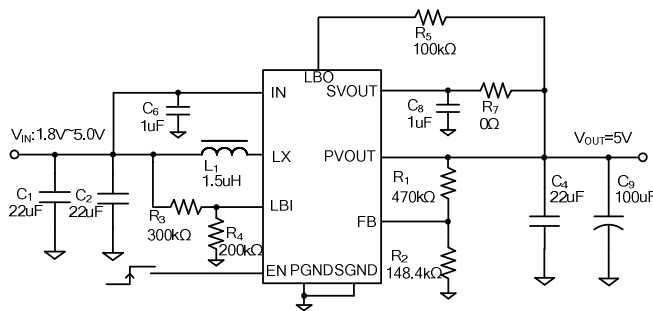

Figure 1. Schematic Diagram

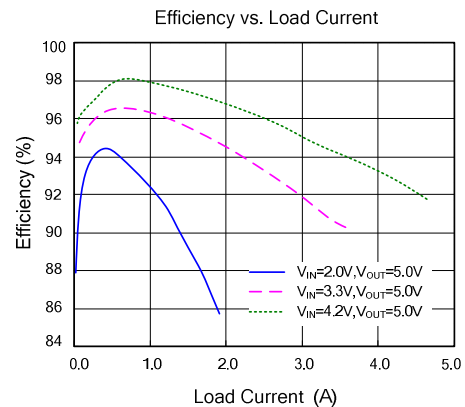
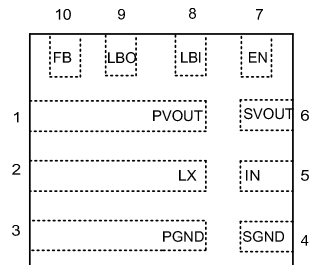

Figure 2. Efficiency Figure



Pinout (top view)



(QFN2X2-10)

Top mark: **MGxyz** for SY7066 (Device code: MG., x=year code, y=week code, z=lot number code)
Axyz for SY7066A (Device code: Aa., x=year code, y=week code, z=lot number code)

Name	QFN2X2-10	Description
PVOUT	1	Power output pin. Decouple this pin to GND pin with at least 22uF ceramic cap.
SVOUT	6	Signal output pin. Decouple this pin to GND pin with at least 1.0uF ceramic cap for noise immunity consideration.
LX	2	Inductor node. Connect an inductor between IN pin and LX pin.
PGND	3	Power ground pin.
SGND	4	Signal ground pin.
IN	5	Signal input pin.
EN	7	Enable pin. Internal integrated with 1Mohm pull down resistor.
LBI	8	Low battery comparator input.
FB	10	Feedback pin. Connect a resistor R1 between OUT and FB, and a resistor R2 between FB and GND to program the output voltage. $V_{OUT}=1.2V*(R_1/R_2+1)$.
LBO	9	Low battery comparator output.(open drain) .

Absolute Maximum Ratings (Note 1)

EN	-----	$V_{OUT}+0.3V$
Other Pins	-----	6V
Power Dissipation, P_D @ $T_A=25^\circ C$ QFN2x2-10	-----	2.5W
Package Thermal Resistance (Note 2)		
θ_{JA}	-----	50°C/W
θ_{JC}	-----	10°C/W
Junction Temperature Range	-----	150°C
Lead Temperature (Soldering, 10 sec.)	-----	260°C
Storage Temperature Range	-----	-65°C to 150°C

Recommended Operating Conditions (Note 3)

IN	-----	1.8V to 5.25V
PVOUT, SVOUT	-----	2.5V to 5.5V
EN	-----	0V to $V_{OUT}+0.3V$
All other pins	-----	0-5.5V
Junction Temperature Range	-----	-40°C to 125°C
Ambient Temperature Range	-----	-40°C to 85°C



Electrical Characteristics

($V_{IN}=2.4V$, $V_{OUT}=5V$, $I_{OUT}=500mA$, $T_A = 25^{\circ}C$ unless otherwise specified)

Parameter	Symbol	Test Conditions	Min	Typ	Max	Unit
Input Voltage	V_{IN}		1.8		5.25	V
Output Voltage Range	V_{OUT}		2.5		5.5	V
Quiescent Current	V_{IN}	$I_O=0A, V_{EN}=V_{IN}=1.8V, V_{OUT}=5.0V$		10		μA
	V_{OUT}			27		μA
Shutdown Current	I_{SHDN}	$V_{EN}=0V, V_{IN}=2.4V$		0.1	1	μA
Linear charge current	I_{CHARGE}	$V_{OUT} \leq 1V$		1.2		A
		$1V < V_{OUT} < 90\% V_{IN}$		1.0		
Soft-start time	T_{SS}			1		ms
Input Vin UVLO threshold	V_{UVLO}				1.78	V
Vin UVLO hysteresis	V_{HYS}			0.1		V
EN Rising Threshold	V_{ENH}		1.2			V
EN Falling Threshold	V_{ENL}				0.4	V
LBI Voltage Threshold	V_{LBI}		1.176	1.2	1.224	V
LBI Input Hysteresis	V_{LBI_HYS}			20		mV
Low Side Main FET R_{ON}	$R_{DS(ON)1}$	$V_{OUT}=5.0V$		20		$m\Omega$
Synchronous FET R_{ON}	$R_{DS(ON)2}$	$V_{OUT}=5.0V$		40		$m\Omega$
Main FET Current Limit	I_{LIM1}		6.0			A
Switching Frequency	f_{SW}			500		kHz
Feedback Reference Voltage	V_{REF}		1.182	1.2	1.218	V
Output over voltage protection	V_{OVP}			6		V
Minimum on time	T_{ON_MIN}			100		ns
Minimum off time	T_{OFF_MIN}			100		ns
Max on time	T_{ON_MAX}			2		μs
Thermal Shutdown Temperature	T_{SD}			150		$^{\circ}C$
Thermal Shutdown hysteresis	T_{HYS}			20		$^{\circ}C$
Output Discharge Resistor	R_{DSC}			80		Ω

Note 1: Stresses beyond the “Absolute Maximum Ratings” may cause permanent damage to the device. These are stress ratings only. Functional operation of the device at these or any other conditions beyond those indicated in the operational sections of the specification is not implied. Exposure to absolute maximum rating conditions may affect device reliability.

Note 2: θ_{JA} is measured in the natural convection at $T_A = 25^{\circ}C$ on a four-layer Silergy Evaluation Board..

Note 3: The device is not guaranteed to function outside its operating conditions.



Block Diagram

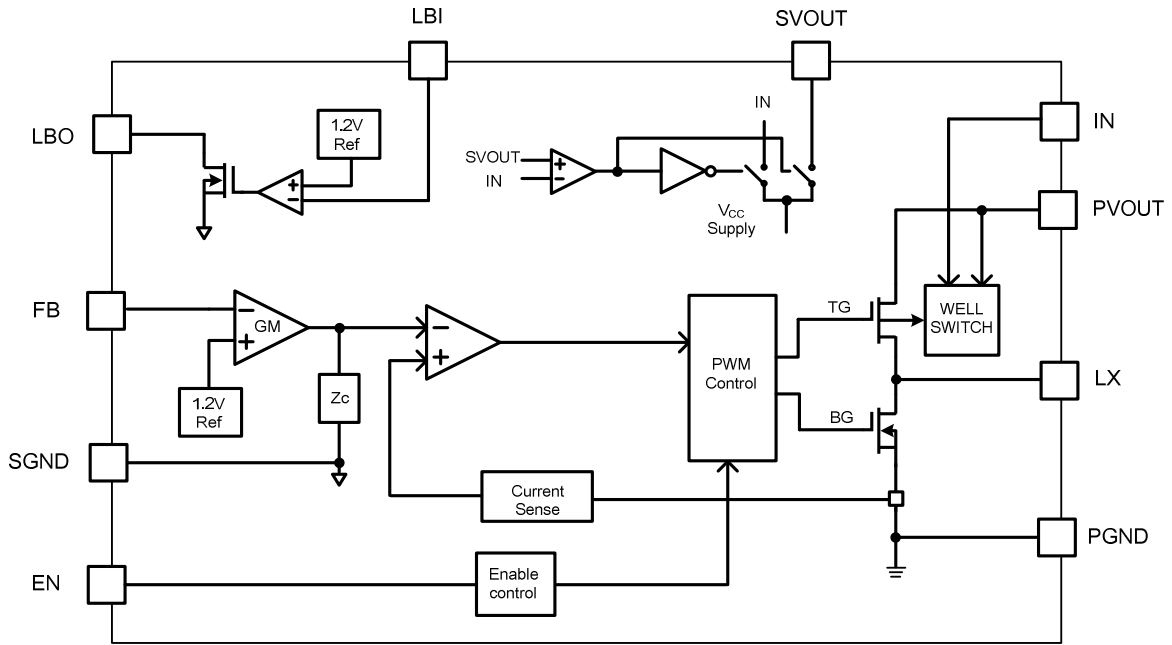



Typical Performance Characteristics

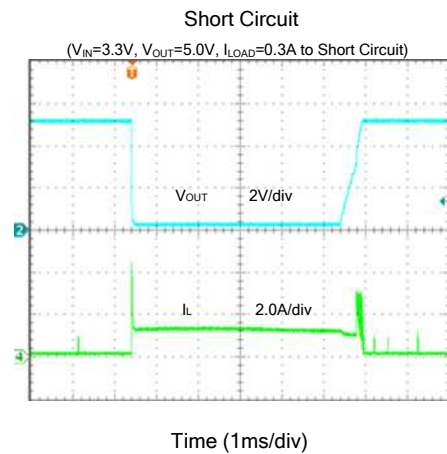
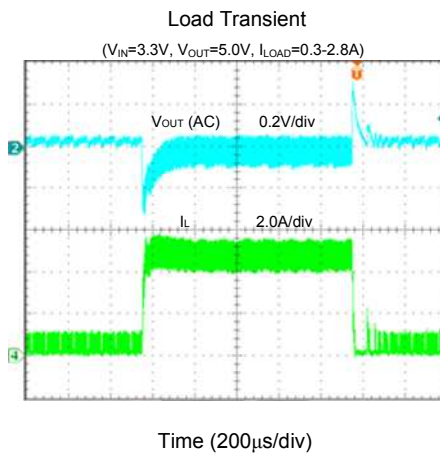
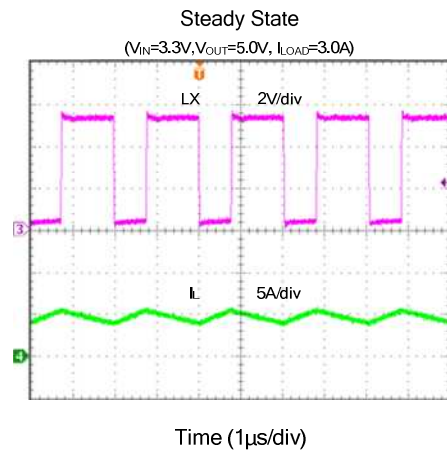
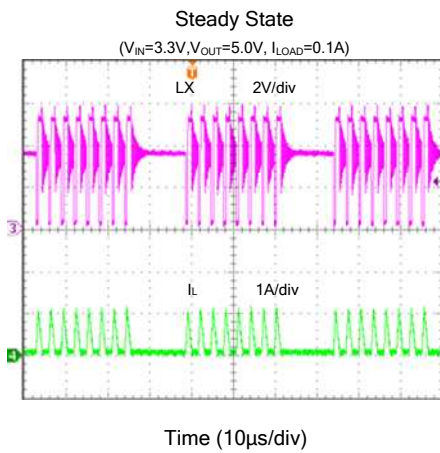
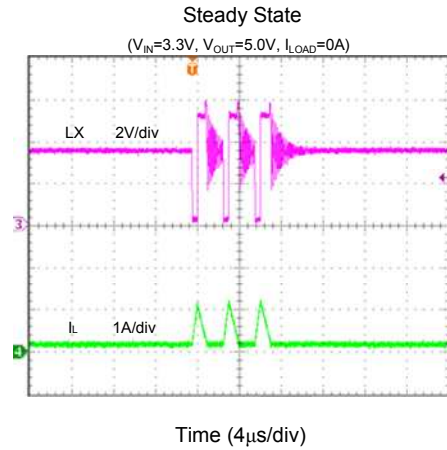
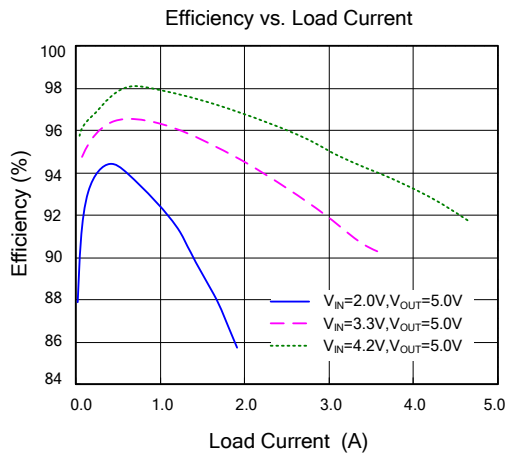



AN_SY7066/A

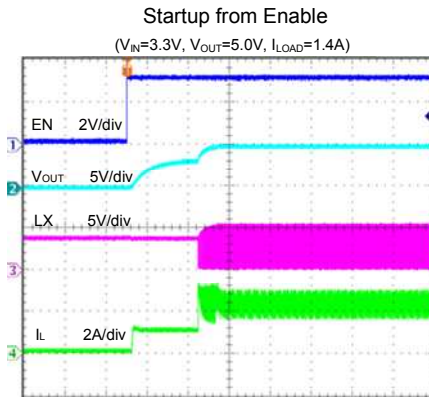

Time (1ms/div)

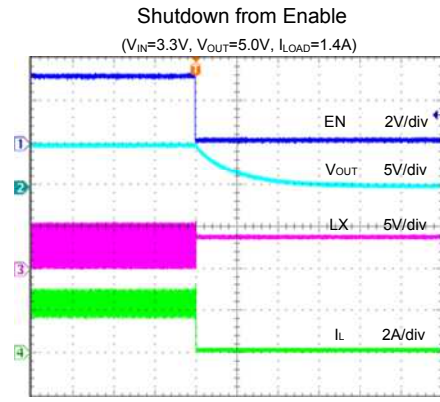

Time (400µs/div)

Applications Information

Because of the high integration for SY7066, only input capacitor C_{IN} , output capacitor C_{OUT} , inductor L and feedback resistors (R_1 and R_2) need to be selected for the targeted applications specifications.

Feedback resistor dividers R_1 and R_2 :

Choose R_1 and R_2 to program the proper output voltage. To minimize the power consumption under light loads, it is desirable to choose large resistance values for both R_1 and R_2 . A value of between $10k\Omega$ and $1M\Omega$ is recommended for both resistors. If V_{OUT} is $5.0V$, $R_1=470k\Omega$ is chosen, using following equation, then R_2 can be calculated to be $148.4k\Omega$:

$$R_2 = \frac{1.2V}{V_{OUT} - 1.2V} R_1$$

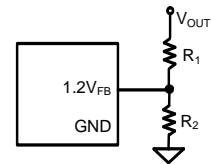

(1)

Input capacitor C_{IN} :

The input capacitor is selected to handle the input ripple current requirements. For the best performance, it is recommended to use X5R or better grade ceramic capacitor with $6.3V$ rating and greater than $22\mu F$ capacitance.

Li-Ion battery hot plug consideration:

In the mass production stage, the Li-Ion Battery will always hot plug in between IC IN and GND pin. The hot plug may lead to large voltage spike and even lead to IC EOS fail. To avoid this potential risk, 1pcs $22\mu F$ ceramic cap serial with 0.1Ω resistor is recommended to absorb the input voltage spike.

With the recommended input absorb solution, the voltage spike can be reduced from $6.13V$ to $5.29V$.

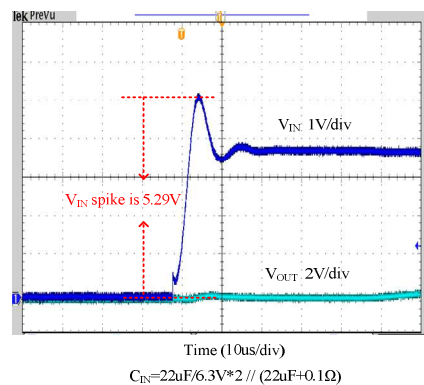
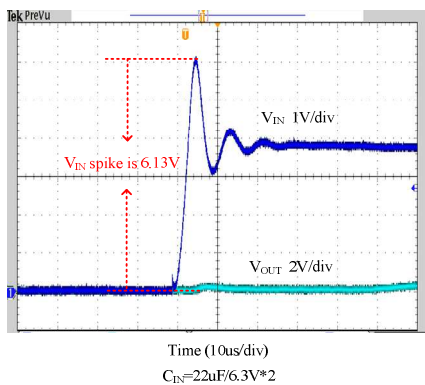
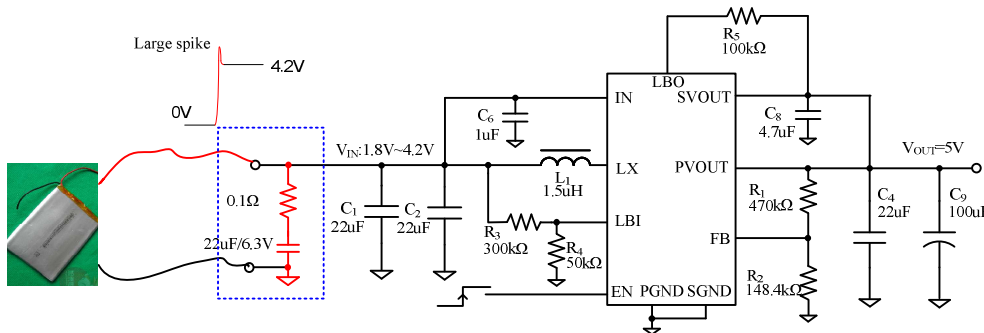

Inductor L Selection:

There are several considerations in choosing this inductor.

- 1) Choose the inductance to provide the desired ripple current. It is suggested to choose the ripple current to be about 40% of the maximum output current. The inductance is calculated as:

$$L = \left(\frac{V_{IN}}{V_{OUT}} \right)^2 \frac{(V_{OUT} - V_{IN})}{F_{SW} \times I_{OUT,MAX} \times 40\%} \quad (2)$$

where F_{SW} is the switching frequency and $I_{OUT,MAX}$ is the maximum load current. The SY7066 regulator IC is quite tolerant of different ripple current amplitude. Consequently, the final choice of inductance can be slightly off the calculation value without significantly impacting the performance.

- 2) The saturation current rating of the inductor must be selected to be greater than the peak inductor current under full load conditions.

$$I_{SAT,MIN} > \left(\frac{V_{OUT}}{V_{IN}} \right) \times I_{OUT,MAX} + \frac{V_{IN}}{V_{OUT}} \frac{(V_{OUT} - V_{IN})}{2 \times F_{SW} \times L} \quad (3)$$

- 3) The DCR of the inductor and the core loss at the switching frequency must be low enough to achieve the desired efficiency requirement. It is desirable to choose an inductor with $DCR < 50\text{mohm}$ to achieve a good overall efficiency.

Inductor Vs. Output Capacitor:

The output capacitor is selected to handle the output ripple noise requirements. Both steady state ripple and transient requirements must be taken into consideration when selecting this capacitor. Care should be taken to minimize the loop area formed by C_{OUT} , and OUT/GND pins. It's recommended to use a X5R or better grade ceramic capacitor with 10V rating and great than 22uF capacitance to decouple the high frequency current. And also a tantalum capacitor with 16V rating and great than 100uF capacitance is recommended for the stability consideration.

All continuous mode boost converters have a right half plane zero (RHPZ) due to the inductor being removed from the output during charging. In a converter with current mode control, inner current feedback loop allows the switch, inductor and modulator to be lumped together into a small signal variable current source, shown as follow.

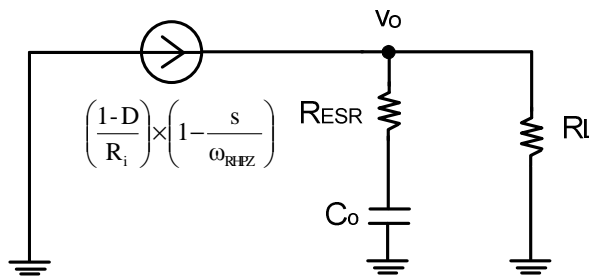

the power stage approximate transfer function is:

$$G_c(s) = \frac{(1-D) \times R_L}{R_i} \times \frac{\left(1 + \frac{s}{\omega_{ESR}} \right) \left(1 - \frac{s}{\omega_{RHPZ}} \right)}{1 + \frac{s}{\omega_p}} \quad (4)$$



Where

$$\omega_{ESR} = \frac{1}{R_{ESR} C_O} \tag{5}$$

$$\omega_P = \frac{1}{(R_{ESR} + R_L) \times C_O} \tag{6}$$

$$\omega_{RHPZ} = \frac{R_L}{L} \times \left(\frac{V_{IN}}{V_{OUT}} \right)^2 \tag{7}$$

As the equation 4 shows, Boost convert with current mode control transfer function is consist of one ESR zero, one right half plane zero and one pole. Right half plane zero brings 20dB/decade gain increase, 90 degrees phase drop. So the bandwidth of boost converter MUST be lower than f_{RHPZ} .

As shown in equation 7, right half plane zero is depend on R_L , L and duty cycle. Larger inductor lead to lower f_{RHPZ} , so bandwidth should be designed lower than f_{RHPZ} .

Some low profile application may prefer to use the ceramic capacitor solution and some low cost application may use the Electrolytic cap to reduce the BOM cost.

Below is selection table based on different inductance and output capacitor.

Inductance Vs. Output Capacitor Selection Table

Inductance		Low profile capacitor application		Low cost capacitor application
Part Number	L(uH)	Part Number	C _{OUT} (uF)	C _{OUT} (uF)
SPM6530T-1R0M	1.0	C3216X5R1A226M	22uF/10V×3pcs	22uF/10V+100uF(E-cap)
SPM6530T-1R5M	1.5	C3216X5R1A226M	22uF/10V×4pcs	22uF/10V+100uF(E-cap)
SPM6530T-2R2M	2.2	C3216X5R1A226M	22uF/10V×5pcs	22uF/10V+200uF(E-cap)

Enable Operation

Pulling the EN pin low (<0.4V) will shut down the device. During shutdown mode, the SY7066 shutdown current drops to lower than 1uA, driving the EN pin high (> 1.2V) will turn on the IC again.

Low Battery Detector Function-LBI/LBO

The low-battery detector function is used to monitor the battery voltage and to generate an error flag when the battery voltage drops below a user-set threshold voltage.

The function is active only when the device is enabled. When the device is disabled, LBO stays at high impedance. The detection threshold is 1.2V at LBI. During normal operation, LBO stays at high impedance when the voltage applied at LBI is above the threshold. It is active low when the voltage at LBI goes below 1.2V.

The battery voltage, at which the detection circuit switches, can be programmed with a resistive divider connected to LBI pin. The resistive divider scales down the battery voltage to a voltage level of 1.2V, which is then compared to LBI threshold voltage. The LBI pin has a built-in hysteresis of 20mV. If the low-battery detection circuit is not used, the LBI pin should be connected to GND (or to VBAT) and the LBO pin can be left unconnected. Do not let the LBI pin float.

R_3 and R_4 are designed to program the proper low battery threshold voltage. The voltage across R_4 is equal to the LBI voltage threshold that is generated on-chip, which has a value of 1.2V. The value of resistor R_3 , depending on the desired minimum battery voltage VBAT, can be calculated as:

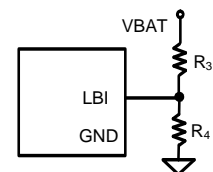

$$R_3 = \frac{V_{BAT} - 1.2V}{1.2V} R_4 \quad (9)$$

The output of the low battery monitor is a simple open-drain output that goes active low if the dedicated battery voltage drops below the programmed threshold voltage on LBI. The output requires a pull up resistor with a recommended value of 100kΩ. The maximum voltage which is used to pull up the LBO outputs should not exceed the output voltage of the DC/DC converter. If not used, the LBO pin can be left floating or tied to GND.

Layout Design Consideration:

For the best efficiency and minimum noise problems, we should place the following components close to the IC: C_{IN}, C_{OUT}, L, R₁ and R₂.

- 1) It is desirable to maximize the PCB copper area connecting to PGND pin to achieve the best thermal and noise performance. If the board space allowed, a ground plane is highly recommended.
- 2) C_{OUT} must be close with Pins PVOUT and PGND. The loop area formed by C_{OUT} and GND must be minimized.
- 3) To minimize the output decouple loop area, LX trace is recommended to be routed on bottom or middle layer through via.
- 4) SVOUT is the power supply pin for the internal control circuit. Don't connect to PVOUT pin directly. A 4.7uF ceramic cap is strongly recommended to decouple SVOUT pin to SGND pin. Please use a jump wire to connect SVOUT pin to output capacitor side.
- 5) The PCB copper area associated with LX pin must be minimized to avoid the potential noise problem.
- 6) The components R₁ and R₂, and the trace connecting to the FB pin must not be adjacent to the LX net on the PCB layout to avoid the noise problem.

PCB Layout Suggestion

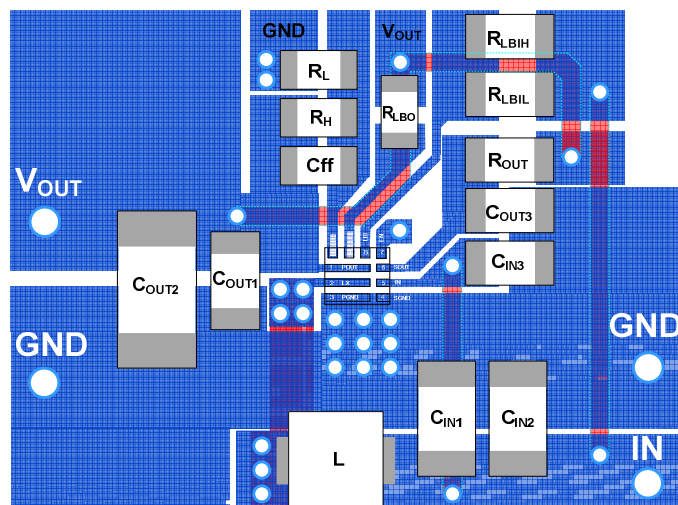
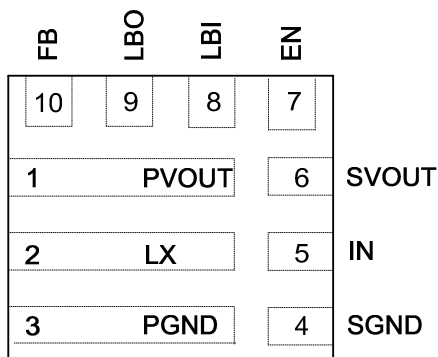

QFN2x2-10L FC Package Outline

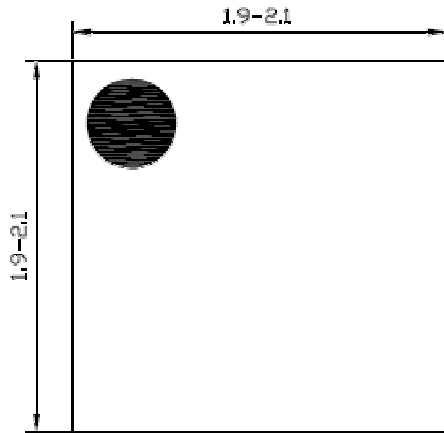

Top View

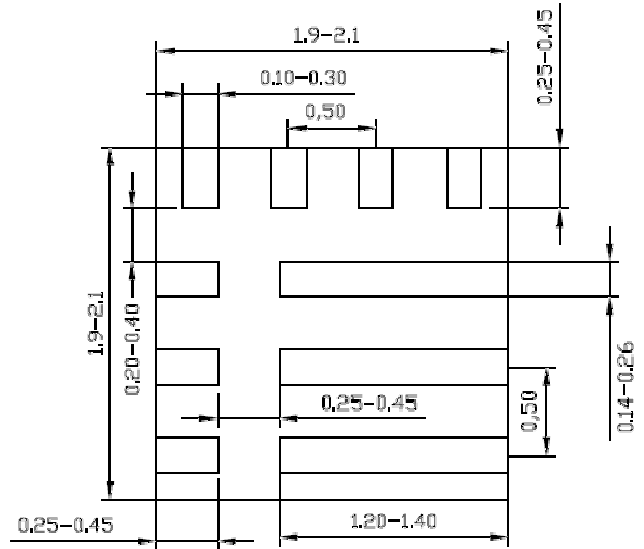

Bottom View

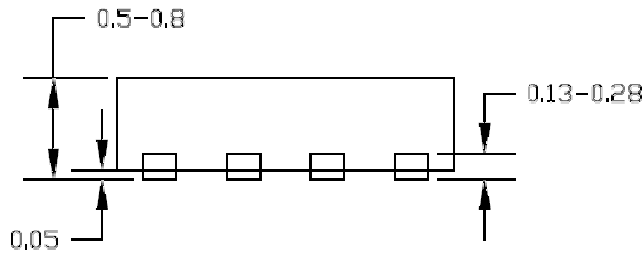

Side View

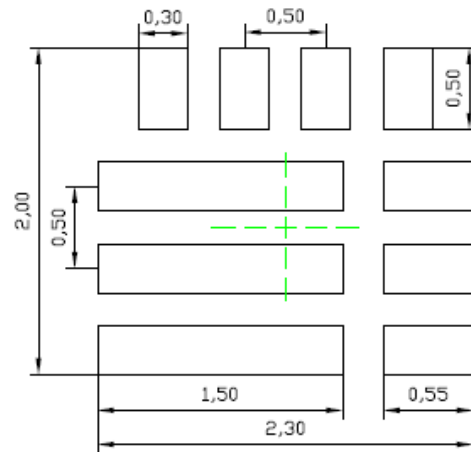

**Recommended PCB Layout
(Reference only)**

Notes: All dimension in MM and exclude mold flash & metal burr.

Taping & Reel Specification

1. Taping orientation

QFN2x2

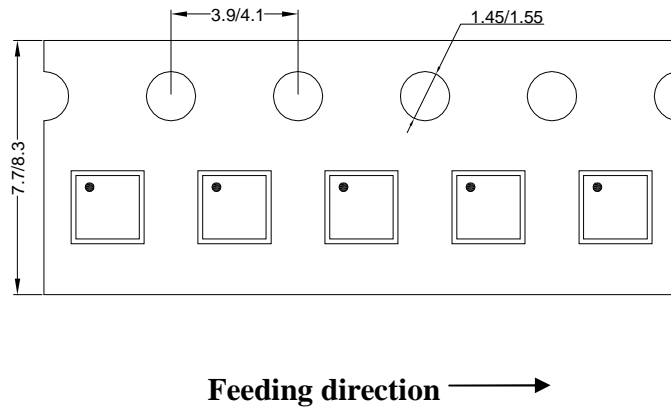

2. Carrier Tape & Reel specification for packages

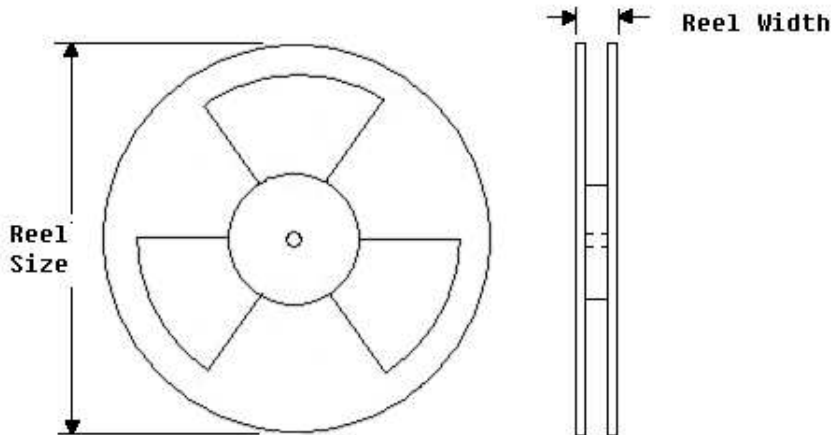

Package types	Tape width (mm)	Pocket pitch(mm)	Reel size (Inch)	Reel width(mm)	Trailer length(mm)	Leader length (mm)	Qty per reel
QFN2x2	8	4	7"	8.4	400	160	3000

3. Others: NA