

## 具有 3.3V 线性稳压器和安全装置定时器的 12 通道, 16 位, 增强型频谱脉宽调制 (PWM), 三原色 (RGB), LED 驱动器

查询样品: [TLC59711](#)

### 特性

- 12 个恒定流入电流源输出通道
- 电流能力: 每通道 **60mA**
- 使用增强型频谱 **PWM** 的灰度 (**GS**) 控制: **16 位 (65536 等级)**
- 全局亮度控制 (**BC**): 对于每个色组 **7 位 (128 等级)**
- 电源电压范围:  
内部线性稳压器: **4.0V 至 17V**  
直流屏电源: **3.0V 至 5.5V**
- **LED 电源**: 高达 **17V**
- 恒定电流精度:
  - 通道到通道 = **±1%** (典型值), **±3%** (最大值)
  - 器件到器件 = **±1%** (典型值), **±4%** (最大值)
- 数据传输速率: **10MHz** (层叠)
- 线性电压稳压器: **3.3V**
- 自动重复显示功能
- 显示计时复位功能
- 内部/外部可选 **GS** 时钟
- 带有自动重新启动的热关断 (**TSD**)
- 不受限器件级联
- 针对外部时钟故障的安全装置定时器
- 工作温度范围: **-40°C 至 +85°C**

### 应用范围

- **RGB LED 射灯显示**

### 说明

TLC59711 是一款 12 通道, 恒定灌电流驱动器。每个输出通道有独立的可调电流, 此电流具有 65536 PWM 灰度 (GS) 等级。此外, 每个色组可由带有全局亮度控制 (BC) 功能的 128 恒定流入电流源等级控制。GS 控制和 BC 可通过一个两线制信号接口进行访问。每个通道的最大电流由一个单一外部电阻器设定。当 IC 过热时, 所有恒定电流输出被关闭。

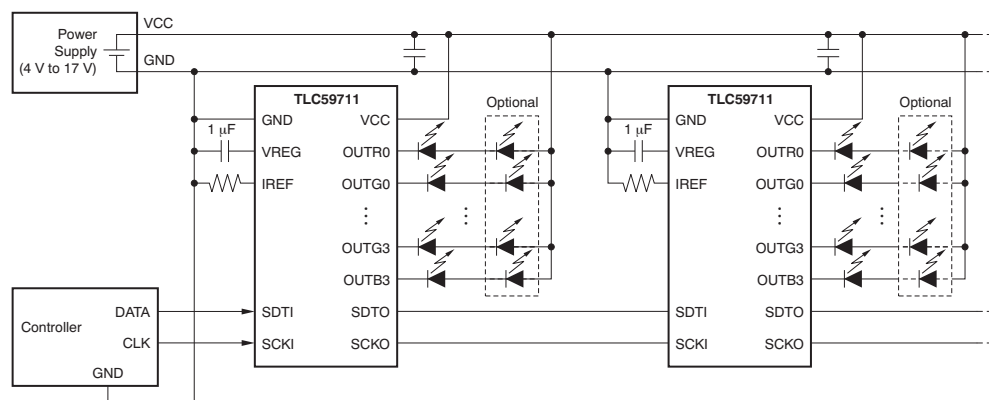

Please be aware that an important notice concerning availability, standard warranty, and use in critical applications of Texas Instruments semiconductor products and disclaimers thereto appears at the end of this data sheet.

PowerPAD is a trademark of Texas Instruments Incorporated.

All other trademarks are the property of their respective owners.

注释：根据 VCC 电压的不同，串联的 LED 的数量会发生变化。

典型应用电路示例  
(V<sub>CC</sub>=4V 至 17V 的内部线性稳压器)

说明 (继续)

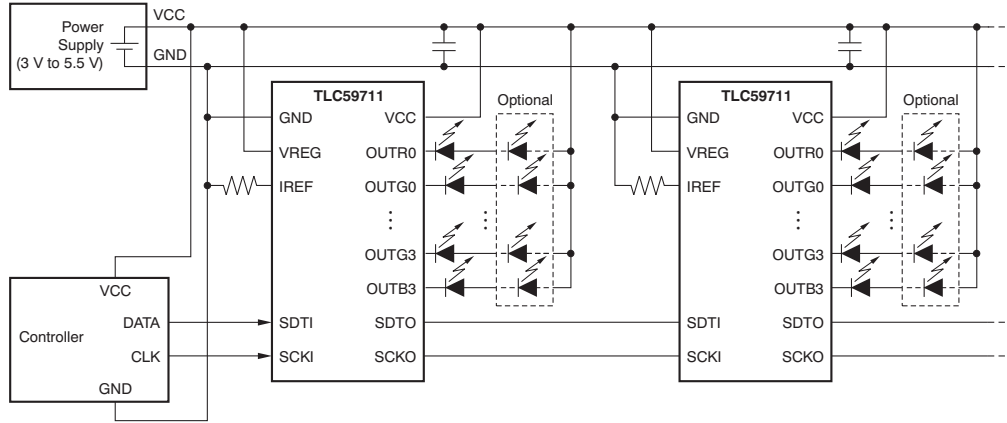

注释：根据 VCC 电压的不同，串联的 LED 的数量会发生变化。

典型应用电路示例  
(直流屏供电 V<sub>CC</sub>=3V 至 5.5V)

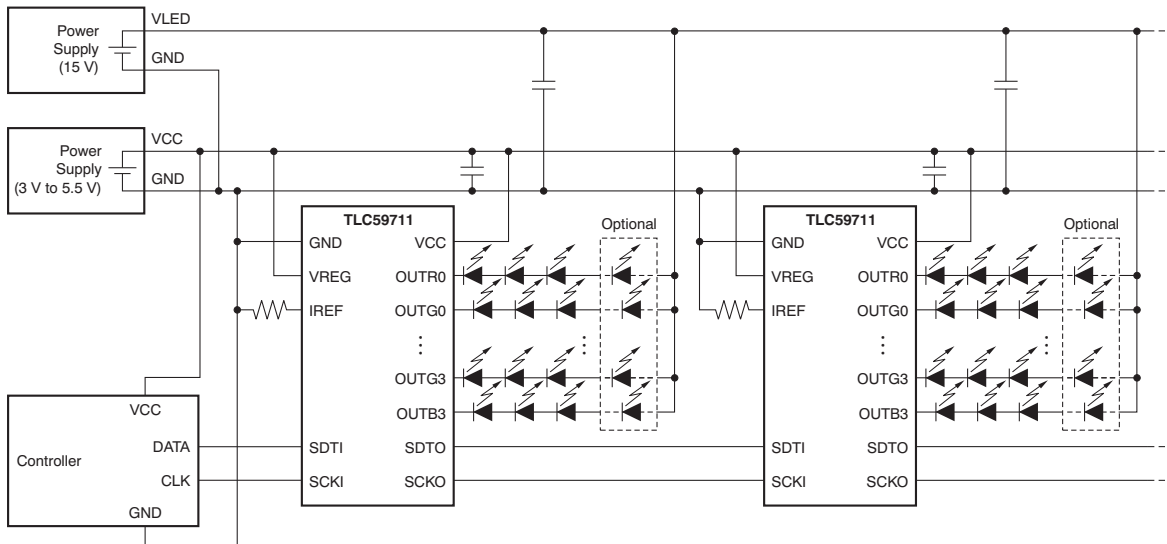

注释：根据 VLED 电压的不同，串联的 LED 的数量会发生变化。

典型应用电路示例  
(直流屏供电 V<sub>CC</sub>=3V 至 5.5V, V<sub>LED</sub>=15V)



This integrated circuit can be damaged by ESD. Texas Instruments recommends that all integrated circuits be handled with appropriate precautions. Failure to observe proper handling and installation procedures can cause damage.

ESD damage can range from subtle performance degradation to complete device failure. Precision integrated circuits may be more susceptible to damage because very small parametric changes could cause the device not to meet its published specifications.

### ORDERING INFORMATION<sup>(1)</sup>

PRODUCT	PACKAGE-LEAD	PACKAGE DESIGNATOR	ORDERING NUMBER	TRANSPORT MEDIA, QUANTITY
TLC59711	HTSSOP-20 PowerPAD™	PWP	TLC59711PWPR	Tape and Reel, 2000
			TLC59711PWP	Tube, 70

(1) For the most current package and ordering information, see the Package Option Addendum at the end of this document, or visit the device product folder at [www.ti.com](http://www.ti.com).

### ABSOLUTE MAXIMUM RATINGS<sup>(1)(2)</sup>

Over operating free-air temperature range, unless otherwise noted.

		VALUE		UNIT
		MIN	MAX	
Supply voltage	VCC	-0.3	+18	V
Input voltage	IREF	-0.3	VREG + 0.3	V
	SDTI, SCKI	-0.3	VREG + 0.6	V
Output voltage	OUTR0 to OUTR3, OUTG0 to OUTG3, OUTB0 to OUTB3	-0.3	+18	V
	SDTO, SCKO	-0.3	VREG + 0.3	V
	VREG	-0.3	+6	V
Output current (DC)	OUTR0 to OUTR3, OUTG0 to OUTG3, OUTB0 to OUTB3		75	mA
	VREG		-30	mA
Operating junction temperature	T <sub>J (max)</sub>		+150	°C
Storage temperature	T <sub>stg</sub>	-55	+150	°C
Electrostatic discharge rating	Human body model (HBM)		4	kV
	Charged device model (CDM)		2	kV

(1) Stresses beyond those listed under *absolute maximum ratings* may cause permanent damage to the device. These are stress ratings only, and functional operation of the device at these or any other conditions beyond those indicated under *recommended operating conditions* is not implied. Exposure to absolute-maximum-rated conditions for extended periods may affect device reliability.

(2) All voltage values are with respect to network ground terminal.

### THERMAL INFORMATION

THERMAL METRIC <sup>(1)</sup>		TLC59711	UNITS
		PWP	
		20 PINS	
$\theta_{JA}$	Junction-to-ambient thermal resistance	68.6	°C/W
$\theta_{JCTop}$	Junction-to-case (top) thermal resistance	44.2	
$\theta_{JB}$	Junction-to-board thermal resistance	19.3	
$\psi_{JT}$	Junction-to-top characterization parameter	2.7	
$\psi_{JB}$	Junction-to-board characterization parameter	15.7	
$\theta_{JCbott}$	Junction-to-case (bottom) thermal resistance	1.8	

(1) 有关传统和全新热度的更多信息，请参阅 IC 封装热量应用报告（文献号：SPRA953）。

## RECOMMENDED OPERATING CONDITIONS

At  $T_A = -40^\circ\text{C}$  to  $+85^\circ\text{C}$ , and  $V_{CC} = 4\text{ V}$  to  $17\text{ V}$  or  $V_{CC} = V_{REG} = 3.0\text{ V}$  to  $5.5\text{ V}$ , unless otherwise noted.

		TLC59711			UNIT
		MIN	NOM	MAX	
<b>DC CHARACTERISTICS</b>					
$V_{CC}$	Supply voltage, internal voltage regulator used	4		17	V
$V_{REG}$	Supply voltage, VREG connected to VCC	3	3.3	5.5	V
$V_O$	Voltage applied to output (OUTR0 to OUTR3, OUTG0 to OUTG3, OUTB0 to OUTB3)			17	V
$V_{IH}$	High-level input voltage (SDTI, SCKI)	$0.7 \times V_{REG}$		$V_{REG}$	V
$V_{IL}$	Low-level input voltage (SDTI, SCKI)	GND		$0.3 \times V_{REG}$	V
$V_{IHYS}$	Input voltage hysteresis (SDTI, SCKI)		$0.2 \times V_{REG}$		V
$I_{OH}$	High-level output current (SDTO)			-2	mA
$I_{OL}$	Low-level output current (SDTO)			2	mA
$I_{OLC}$	Constant output sink current (OUTR0 to OUTR3, OUTG0 to OUTG3, OUTB0 to OUTB3)			60	mA
$I_{REG}$	Voltage regulator output current (VREG)			-25	mA
$T_A$	Operating free temperature range	-40		+85	$^\circ\text{C}$
$T_J$	Operating junction temperature	-40		+125	$^\circ\text{C}$
<b>AC CHARACTERISTICS</b>					
$f_{CLK}$ (SCKI)	Data clock frequency and GS control clock frequency, SCKI	0.007		10	MHz
$t_{WH}/t_{WL}$	Pulse duration, SCKI	10			ns
$t_{SU}$	Setup time, SDTI – SCKI $\uparrow$	5			ns
$t_H$	Hold time, SDTI – SCKI $\uparrow$	3			ns

## ELECTRICAL CHARACTERISTICS

At  $T_A = -40^\circ\text{C}$  to  $+85^\circ\text{C}$ ,  $V_{CC} = 4\text{ V}$  to  $17\text{ V}$  or  $V_{CC} = V_{REG} = 3\text{ V}$  to  $5.5\text{ V}$ ,  $V_{LED} = 5\text{ V}$ , and  $C_{VREG} = 1\text{ }\mu\text{F}$ , unless otherwise noted. Typical values are at  $T_A = +25^\circ\text{C}$  and  $V_{CC} = 12\text{ V}$ .

PARAMETER		TEST CONDITIONS	TLC59711			UNIT
			MIN	TYP	MAX	
$V_{OH}$	High-level output voltage, SDTO/SCKO	$I_{OH} = -2\text{ mA}$	$V_{REG} - 0.4$		$V_{REG}$	V
$V_{OL}$	Low-level output voltage, SDTO/SCKO	$I_{OL} = 2\text{ mA}$	0		0.4	V
$V_{IREF}$	Reference voltage output, IREF	$R_{IREF} = 0.82\text{ k}\Omega$	1.18	1.21	1.24	V
$V_{REG}$	Linear regulator output voltage, VREG	$V_{CC} = 4\text{ V}$ to $17\text{ V}$ , $I_{REG} = 0\text{ mA}$ to $-25\text{ mA}$	3.1	3.3	3.5	V
$\Delta V_{REG}$	Line regulation of linear regulator, VREG	$V_{CC} = 4\text{ V}$ to $17\text{ V}$ , $I_{REG} = 0\text{ mA}$			90	mV
$\Delta V_{REG1}$	Load regulation of linear regulator, VREG	$V_{CC} = 12\text{ V}$ , $I_{REG} = 0\text{ mA}$ to $-25\text{ mA}$			120	mV
$V_{STR}$	Undervoltage lockout release, VREG		2.5	2.7	2.9	V
$V_{HYS}$	Undervoltage lockout hysteresis, VREG		300	400	500	mV
$I_i$	Input current, SDTI/SCKI	$V_i = V_{REG}$ or GND	-1		1	$\mu\text{A}$
$I_{CC}$	Supply current	SDTI/SCKI = low, BLANK = 1, GS $n$ = FFFFh, BCX = 7Fh, $V_{OUTXn} = 1\text{ V}$ , $R_{IREF} = 24\text{ k}\Omega$ ( $I_{OLCmax} = 2\text{ mA}$ )		2	4	mA
$I_{CC1}$		SDTI/SCKI = low, BLANK = 1, GS $n$ = FFFFh, BCX = 7Fh, $V_{OUTXn} = 1\text{ V}$ , $R_{IREF} = 1.6\text{ k}\Omega$ ( $I_{OLCmax} = 30\text{ mA}$ )		6	9	mA
$I_{CC2}$		SDTI = 5 MHz, SCKI = 10 MHz, BLANK = 0, auto repeat enable, external GS clock selected, GS $n$ = FFFFh, BCX = 7Fh, $V_{OUTXn} = 1\text{ V}$ , $R_{IREF} = 1.6\text{ k}\Omega$ ( $I_{OLCmax} = 30\text{ mA}$ )		10	18	mA
$I_{CC3}$		SDTI = 5 MHz, SCKI = 10 MHz, BLANK = 0, auto repeat enable, external GS clock selected, GS $n$ = FFFFh, BCX = 7Fh, $V_{OUTXn} = 1\text{ V}$ , $R_{IREF} = 0.82\text{ k}\Omega$ ( $I_{OLCmax} = 60\text{ mA}$ )		16	32	mA
$I_{OLC}$	Constant output current, OUTX $n$	All OUTX $n$ on, BCX = 7Fh, $V_{OUTXn} = 1\text{ V}$ , $V_{OUTIX} = 1\text{ V}$ , $R_{IREF} = 0.82\text{ k}\Omega$ ( $I_{OLCmax} = 60\text{ mA}$ )	56.3	60.5	64.7	mA
$I_{OLKG}$	Leakage output current, OUTX $n$	All OUTX $n$ off, BCX = 7Fh, $V_{OUTXn} = 17\text{ V}$ , $V_{OUTIX} = 17\text{ V}$ , $R_{IREF} = 0.82\text{ k}\Omega$ ( $I_{OLCmax} = 60\text{ mA}$ )			0.1	$\mu\text{A}$

**ELECTRICAL CHARACTERISTICS (continued)**

At  $T_A = -40^\circ\text{C}$  to  $+85^\circ\text{C}$ ,  $V_{CC} = 4\text{ V}$  to  $17\text{ V}$  or  $V_{CC} = V_{REG} = 3\text{ V}$  to  $5.5\text{ V}$ ,  $V_{LED} = 5\text{ V}$ , and  $C_{VREG} = 1\text{ }\mu\text{F}$ , unless otherwise noted. Typical values are at  $T_A = +25^\circ\text{C}$  and  $V_{CC} = 12\text{ V}$ .

PARAMETER		TEST CONDITIONS	TLC59711			UNIT
			MIN	TYP	MAX	
$\Delta I_{OLC}$	Constant-current error <sup>(1)</sup> (channel-to-channel in same color group), $I_{OUTXn}$	All $I_{OUTXn}$ on, $BCX = 7Fh$ , $V_{OUTXn} = V_{OUTfix} = 1\text{ V}$ , $R_{IREF} = 0.82\text{ k}\Omega$ ( $I_{OLCMax} = 60\text{ mA}$ )		$\pm 1$	$\pm 3$	%
$\Delta I_{OLC1}$	Constant current error <sup>(2)</sup> (device-to-device in same color group), $I_{OUTXn}$	All $I_{OUTXn}$ on, $BCX = 7Fh$ , $V_{OUTXn} = V_{OUTfix} = 1\text{ V}$ , $R_{IREF} = 0.82\text{ k}\Omega$ ( $I_{OLCMax} = 60\text{ mA}$ ), at same grouped color output of OUTR0-3, OUTG0-3, and OUTB0-3		$\pm 1$	$\pm 4$	%
$\Delta I_{OLC2}$	Line regulation of constant-current output, $I_{OUTXn}$ <sup>(3)</sup>	All $I_{OUTn}$ on, $BCX = 7Fh$ , $V_{OUTXn} = V_{OUTfix} = 1\text{ V}$ , $R_{IREF} = 0.82\text{ k}\Omega$ ( $I_{OLCMax} = 60\text{ mA}$ )		$\pm 0.5$	$\pm 1$	%/V
$\Delta I_{OLC3}$	Load regulation of constant-current output, $I_{OUTXn}$ <sup>(4)</sup>	All $I_{OUTn}$ on, $BCX = 7Fh$ , $V_{OUTXn} = V_{OUTfix} = 1\text{ V}$ , $R_{IREF} = 0.82\text{ k}\Omega$ ( $I_{OLCMax} = 60\text{ mA}$ )		$\pm 1$	$\pm 3$	%/V
$T_{TSD}$	Thermal shutdown temperature	Junction temperature <sup>(5)</sup>	150	165	180	$^\circ\text{C}$
$T_{HYS}$	Thermal shutdown hysteresis	Junction temperature <sup>(5)</sup>	5	10	20	$^\circ\text{C}$
$V_{IREF}$	Reference voltage output, IREF	$R_{IREF} = 0.82\text{ k}\Omega$	1.18	1.21	1.24	V
$V_{REG}$	Linear regulator output voltage, VREG	$V_{CC} = 4\text{ V}$ to $17\text{ V}$ , $I_{REG} = 0\text{ mA}$ to $-25\text{ mA}$	3.1	3.3	3.5	V
$\Delta V_{REG}$	Line regulation of linear regulator, VREG	$V_{CC} = 4\text{ V}$ to $17\text{ V}$ , $I_{REG} = 0\text{ mA}$			90	mV
$\Delta V_{REG1}$	Load regulation of linear regulator, VREG	$V_{CC} = 12\text{ V}$ , $I_{REG} = 0\text{ mA}$ to $-25\text{ mA}$			120	mV
$V_{STR}$	Undervoltage lockout release, VREG		2.5	2.7	2.9	V
$V_{HYS}$	Undervoltage lockout hysteresis, VREG		300	400	500	mV

- (1) The deviation of each output in the same color group (OUTR0-OUTR3 or OUTG0-OUTG3 or OUTB0-OUTB3) from the average current from the same color group. Deviation is calculated by the formula:

$$\Delta (\%) = \left[ \frac{I_{OLCXn}}{\frac{(I_{OLCX0} + I_{OLCX1} + I_{OLCX2} + I_{OLCX3})}{4}} - 1 \right] \times 100$$

Where:  $X = R/G/B$ , and  $n = 0-3$

- (2) The deviation of each color group constant-current average from the ideal constant-current value. Deviation is calculated by the following formula:

$$\Delta (\%) = \left[ \frac{\frac{(I_{OLCX0} + I_{OLCX1} + I_{OLCX2} + I_{OLCX3})}{4} - (\text{Ideal Output Current})}{\text{Ideal Output Current}} \right] \times 100$$

Where:  $X = R/G/B$ .

Ideal current is calculated by the following formula for the OUTRn and OUTGn groups:

$$I_{OLCXn(\text{IDEAL})} (\text{mA}) = 41 \times \left[ \frac{1.21}{R_{IREF} (\Omega)} \right]$$

Where:  $X = R/G/B$ .

- (3) Line regulation is calculated by this equation:

$$\Delta (\%/V) = \left[ \frac{(I_{OLCXn} \text{ at } V_{CC} = 5.5\text{ V}) - (I_{OLCXn} \text{ at } V_{CC} = 3\text{ V})}{(I_{OLCXn} \text{ at } V_{CC} = 3\text{ V})} \right] \times \frac{100}{5.5\text{ V} - 3\text{ V}}$$

Where:  $X = R/G/B$ ,  $n = 0-3$ .

- (4) Load regulation is calculated by the equation:

$$\Delta (\%/V) = \left[ \frac{(I_{OLCXn} \text{ at } V_{OUTXn} = 3\text{ V}) - (I_{OLCXn} \text{ at } V_{OUTXn} = 1\text{ V})}{(I_{OLCXn} \text{ at } V_{OUTXn} = 1\text{ V})} \right] \times \frac{100}{3\text{ V} - 1\text{ V}}$$

Where:  $X = R/G/B$ ,  $n = 0-3$ .

- (5) Not tested, specified by design.

## SWITCHING CHARACTERISTICS

At  $T_A = -40^\circ\text{C}$  to  $+85^\circ\text{C}$ ,  $V_{CC} = 4\text{ V}$  to  $17\text{ V}$  or  $V_{CC} = V_{REG} = 3\text{ V}$  to  $5.5\text{ V}$ ,  $C_{VREG} = 1\ \mu\text{F}$ ,  $C_L = 15\ \text{pF}$ ,  $R_L = 68\ \Omega$ , and  $V_{LED} = 5\text{ V}$ , unless otherwise noted. Typical values are at  $T_A = +25^\circ\text{C}$  and  $V_{CC} = 12\text{ V}$ .

PARAMETER		TEST CONDITIONS	TLC59711			UNIT
			MIN	TYP	MAX	
$t_{R0}$	Rise time, SDTO/SCKO		4	10	15	ns
$t_{R1}$	Rise time, OUTXn	BCX = 7Fh		5	15	ns
$t_{F0}$	Fall time, SDTO/SCKO		4	10	15	ns
$t_{F1}$	Fall time, OUTXn	BCX = 7Fh		15	25	ns
$t_{D0}$	Propagation delay	SCKI $\uparrow$ to SDTO $\uparrow\downarrow$	44	72	124	ns
$t_{D1}$		SCKI $\uparrow$ to SCKO $\uparrow$ , $V_{REG} = 3.3\text{ V}$	11	22	53	ns
$t_{D2}^{(1)}$		SCKO $\uparrow$ to SDTO $\uparrow\downarrow$ , $V_{REG} = 3.3\text{ V}$	33	50	71	ns
$t_{D3}$		SCKI $\uparrow$ to OUTFn $\uparrow\downarrow$ , BLANK = 0, BCXn = 7Fh, OUTTMG = 1 Or SCKI $\downarrow$ to OUTFn $\uparrow\downarrow$ , BLANK = 0, BCXn = 7Fh, OUTTMG = 0	10	25	60	ns
$t_{D4}$		SCKI $\uparrow$ to OUTGn $\uparrow\downarrow$ , BLANK = 0, BCXn = 7Fh, OUTTMG = 1 Or SCKI $\downarrow$ to OUTGn $\uparrow\downarrow$ , BLANK = 0, BCXn = 7Fh, OUTTMG = 0	25	50	90	ns
$t_{D5}$		SCKI $\uparrow$ to OUTBn $\uparrow\downarrow$ , BLANK = 0, BCXn = 7Fh, OUTTMG = 1 Or SCKI $\downarrow$ to OUTBn $\uparrow\downarrow$ , BLANK = 0, BCXn = 7Fh, OUTTMG = 0	40	75	120	ns
$t_{D6}^{(2)}$		Last SCKI $\uparrow$ to internal latch pulse generation	$8/f_{OSC}$		$16384/f_{OSC}$	sec
$t_{W(SCKO)}$	Shift clock output one pulse width	SCKO $\uparrow$ to SCKO $\downarrow$	29	41	70	ns
$f_{OSC}$	Internal oscillator frequency		7	10	12	MHz

(1) The propagation delays are calculated by  $t_{D2a} = t_{D0a} - t_{D1a}$  or  $t_{D2b} = t_{D0b} - t_{D1b}$ .

(2) The generation timing of the internal latch pulse changes depending on the SCKI clock frequency; see the [Internal Latch Pulse Generation Timing](#) section.

FUNCTIONAL BLOCK DIAGRAM

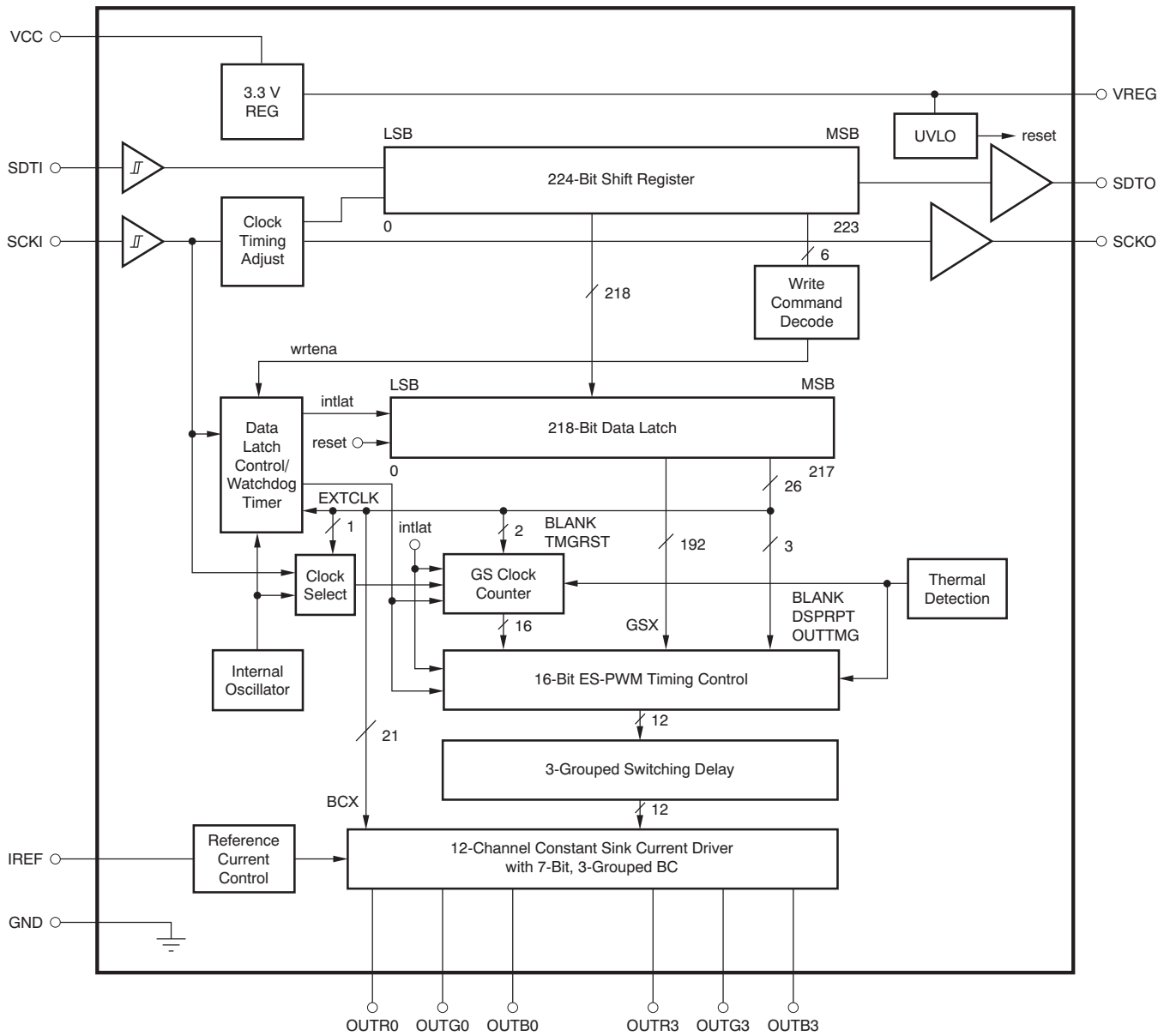

## PIN CONFIGURATIONS

**PWP PACKAGE  
HTSSOP-20 PowerPAD  
(TOP VIEW)**

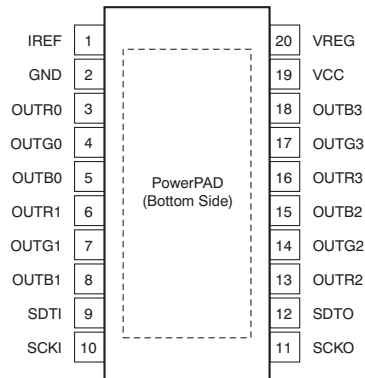

## TERMINAL FUNCTIONS

TERMINAL		I/O	DESCRIPTION
NAME	PWP		
IREF	1	I/O	Maximum current programming terminal. A resistor connected between IREF and GND sets the maximum current for every constant-current output. When this terminal is directly connected to GND, all outputs are forced off. The external resistor should be placed close to the device.
GND	2	—	Power ground terminal
OUTB0	5	O	BLUE constant-current outputs. Multiple outputs can be configured in parallel to increase the constant-current capability. Different voltages can be applied to each output.
OUTB1	8	O	
OUTB2	15	O	
OUTB3	18	O	GREEN constant-current outputs. Multiple outputs can be configured in parallel to increase the constant-current capability. Different voltages can be applied to each output.
OUTG0	4	O	
OUTG1	7	O	
OUTG2	14	O	RED constant-current outputs. Multiple outputs can be configured in parallel to increase the constant-current capability. Different voltages can be applied to each output.
OUTG3	17	O	
OUTR0	3	O	
OUTR1	6	O	Serial data shift clock input. Data present on SDTI are shifted to the LSB of the 224-bit shift register with the SCKI rising edge. Data in the shift register are shifted toward the MSB at each SCKI rising edge. The MSB data of the shift register appear on SDTO.
OUTR2	13	O	
OUTR3	16	O	
SCKI	10	I	Serial data shift clock output. The input shift clock signal from SCKI is adjusted to the timing of the serial data output for SDTO and the signal is then output at SCKO.
SCKO	11	O	
SDTI	9	I	Serial data input for the 224-bit shift register
SDTO	12	O	Serial data output of the 224-bit shift register. SDTO is connected to the MSB of the 224-bit shift register. Data are clocked out at the falling edge SCKO.
VREG	20	I/O	Internal linear voltage regulator output. A decoupling capacitor of 1 $\mu$ F must be connected. This output can be used for external devices as a 3.3-V power supply. This terminal can be connected with the VREG terminal of other devices to increase the supply current. Also, this pin can be supplied with 3 V to 5.5 V from an external power supply by connecting it to VCC.
VCC	19	—	Power-supply terminal



PARAMETRIC MEASUREMENT INFORMATION

PIN EQUIVALENT INPUT/OUTPUT SCHEMATICS

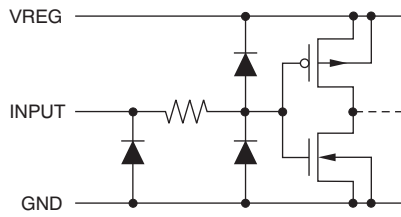

Figure 1. SDTI/SCKI

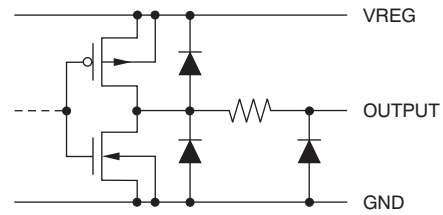
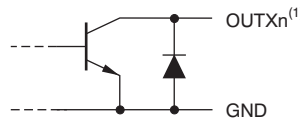

Figure 2. SDTO/SCKO



(1) X = R/G/B, n = 0-3.

Figure 3. OUTR0 Through OUTB3

TEST CIRCUITS

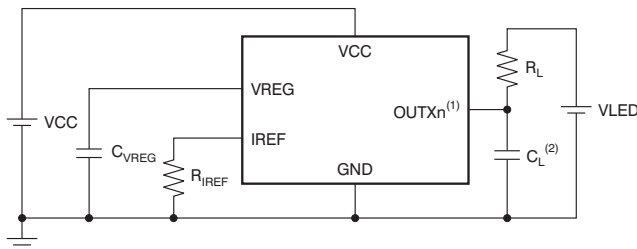

(1) X = R/G/B, n = 0-3.

(2) C<sub>L</sub> includes measurement probe and stray capacitance.

Figure 4. Rise/Fall Time Test Circuit for OUTXn

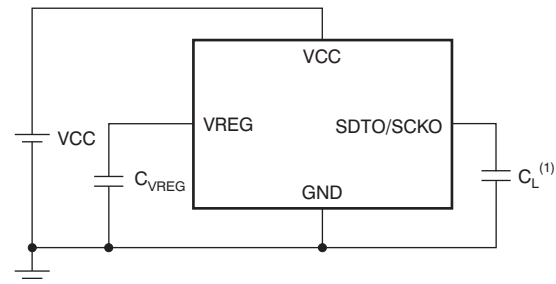

(1) C<sub>L</sub> includes measurement probe and stray capacitance.

Figure 5. Rise/Fall Time Test Circuit for SDTO/SCKO

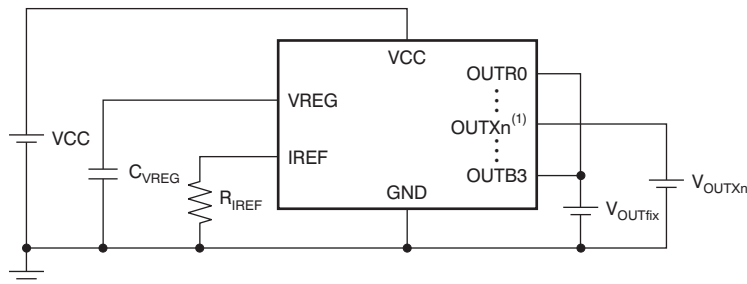

(1) X = R/G/B, n = 0-3.

Figure 6. Constant-Current Test Circuit for OUTXn

**TIMING DIAGRAMS**

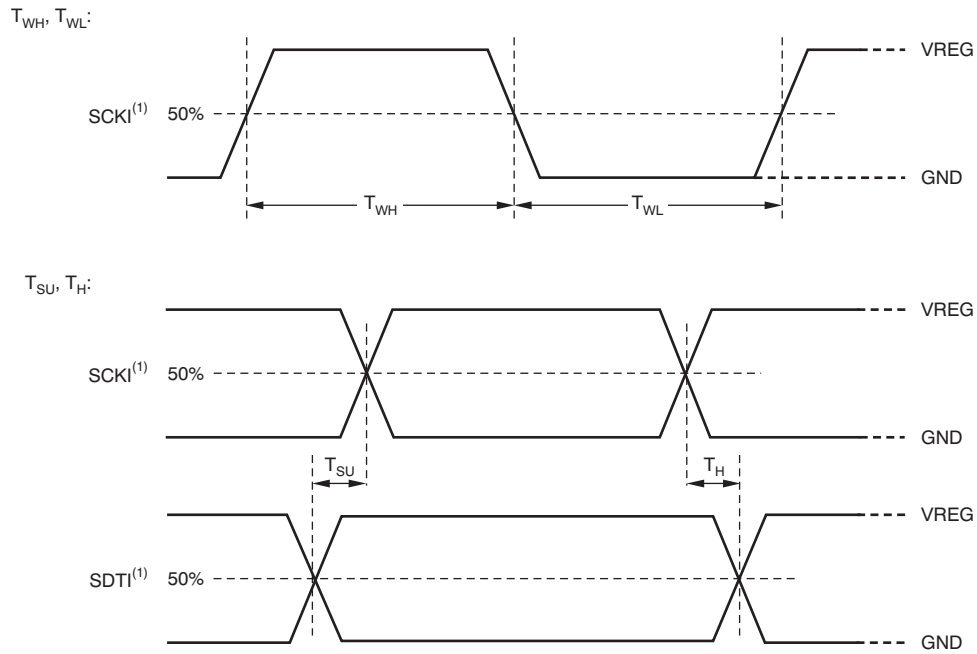

(1) Input pulse rise and fall time is 1ns to 3ns.

**Figure 7. Input Timing**

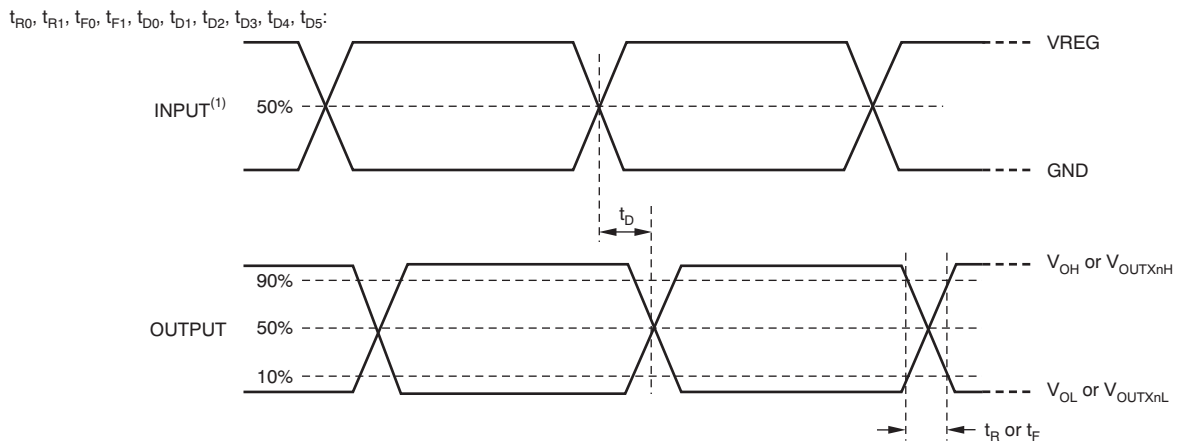

(1) Input pulse rise and fall time is 1ns to 3ns.

**Figure 8. Output Timing**

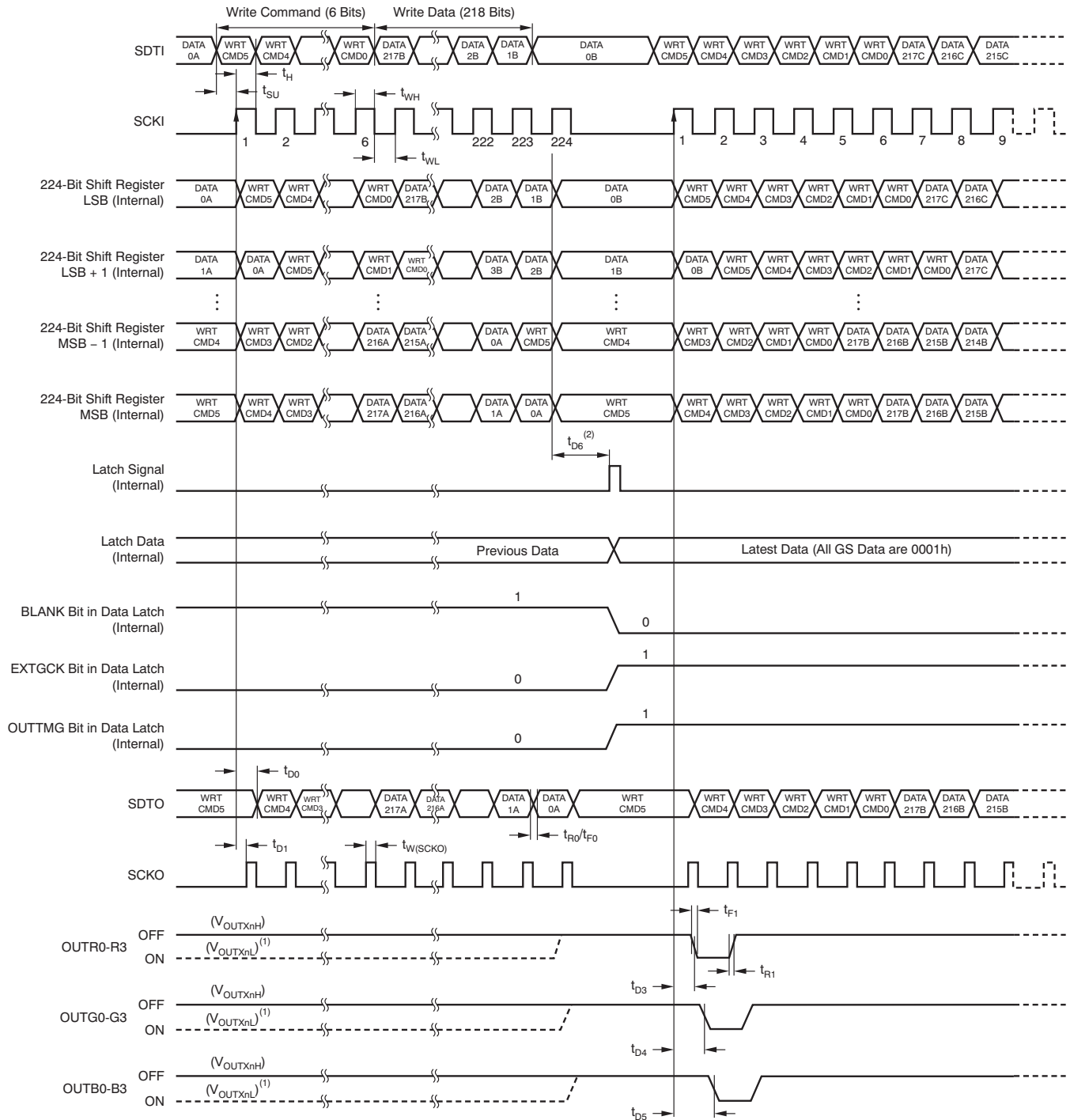

(1) OUTXn on-off timing depends on previous GS data in the 218-bit data latch.

(2) The propagation delay time shows the period from the rising edge of the last SCKI, not the 224th SCKI to the internal latch signal generation.

**Figure 9. Data Write and OUTXn Switching Timing (OUTTMG = 1)**

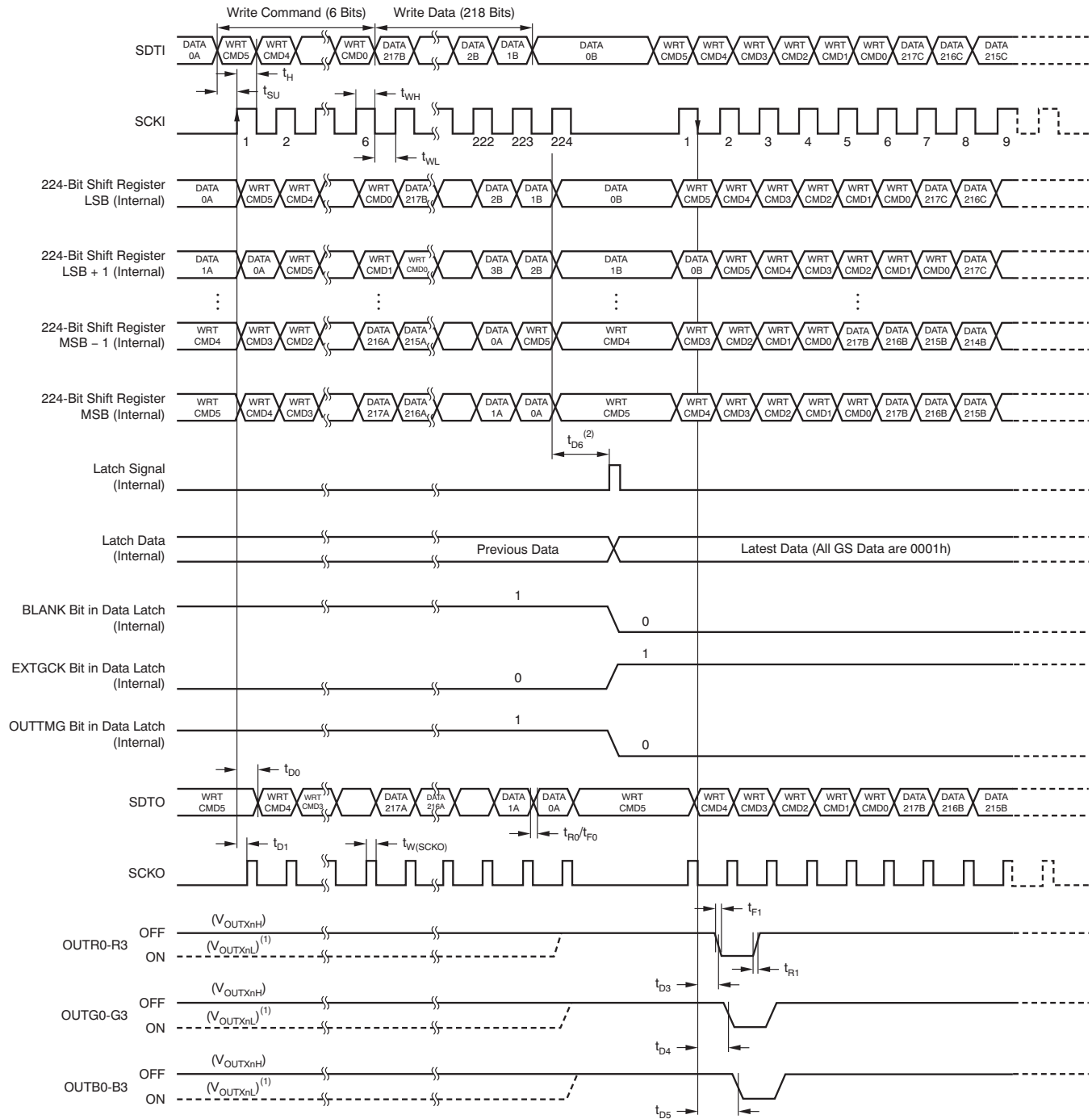

(1) OUTXn on-off timing depends on previous GS data in the 218-bit data latch.

(2) The propagation delay time shows the period from the rising edge of the last SCKI, not the 224th SCKI to the internal latch signal generation.

**Figure 10. Data Write and OUTXn Switching Timing (OUTTMG = 0)**

**TYPICAL CHARACTERISTICS**

At  $T_A = +25^\circ\text{C}$  and  $V_{CC} = 24\text{ V}$ , unless otherwise noted.

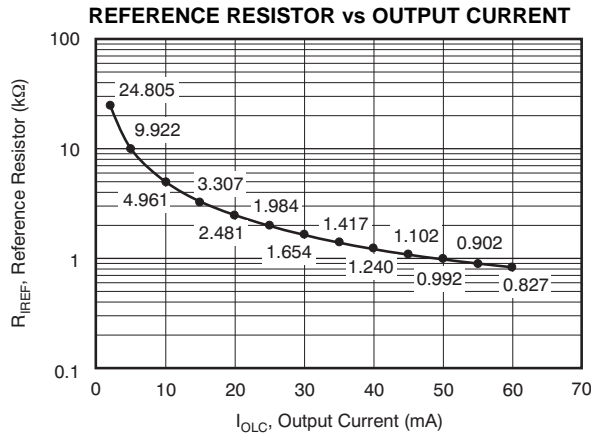

Figure 11.

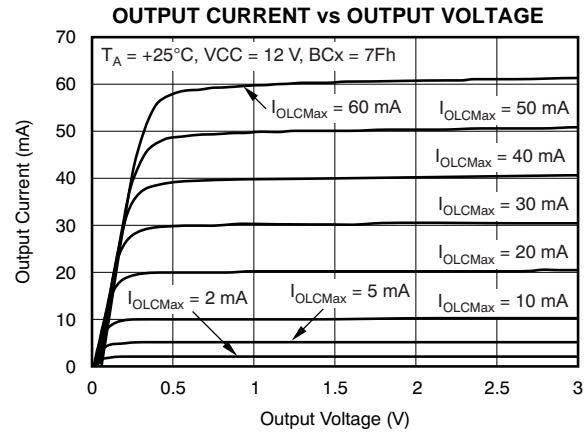

Figure 12.

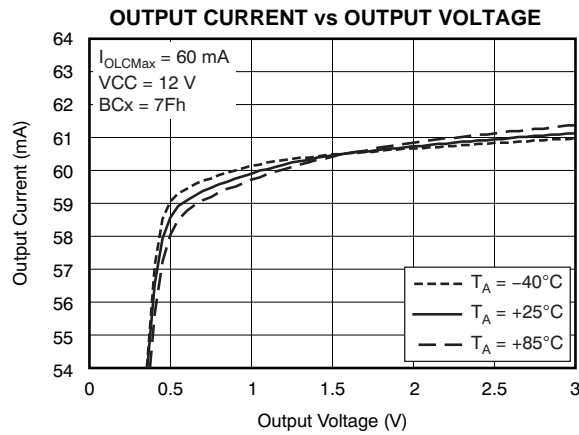

Figure 13.

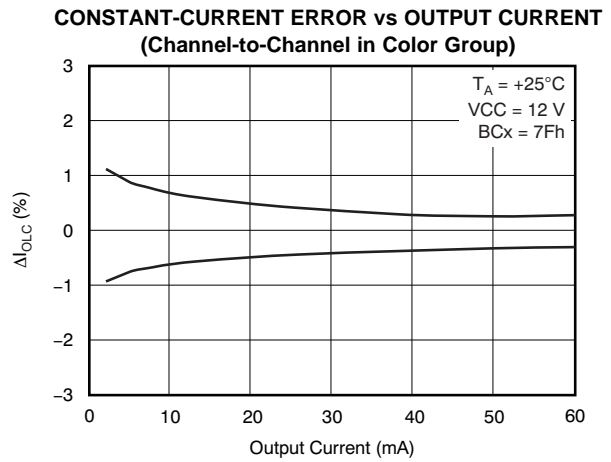

Figure 14.

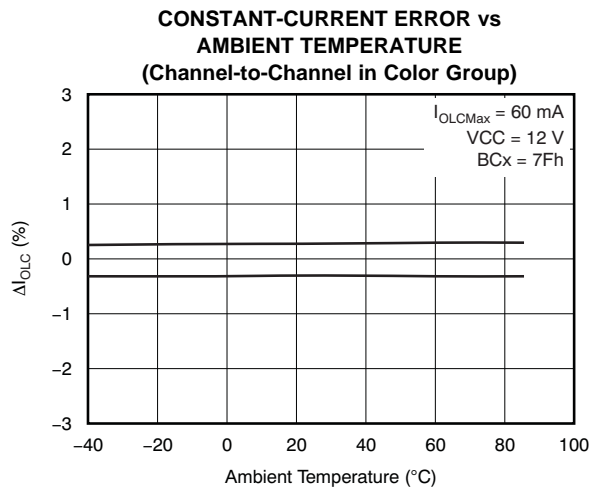

Figure 15.

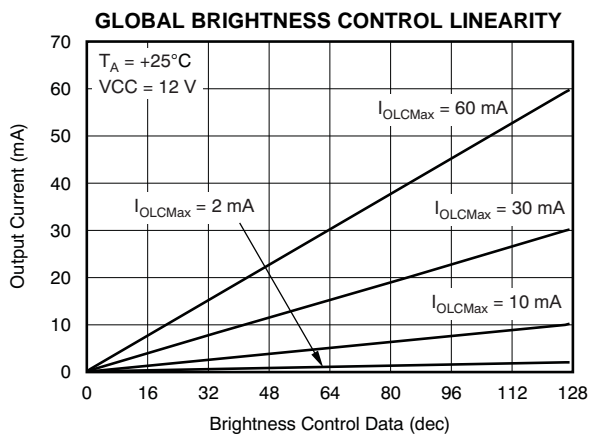

Figure 16.

**TYPICAL CHARACTERISTICS (continued)**

At  $T_A = +25^\circ\text{C}$  and  $V_{CC} = 24\text{ V}$ , unless otherwise noted.

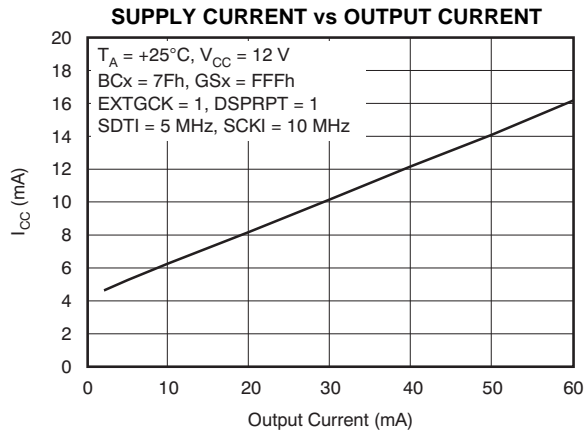

Figure 17.

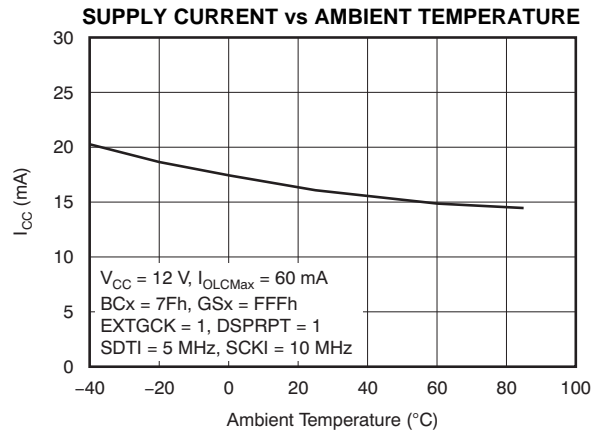

Figure 18.

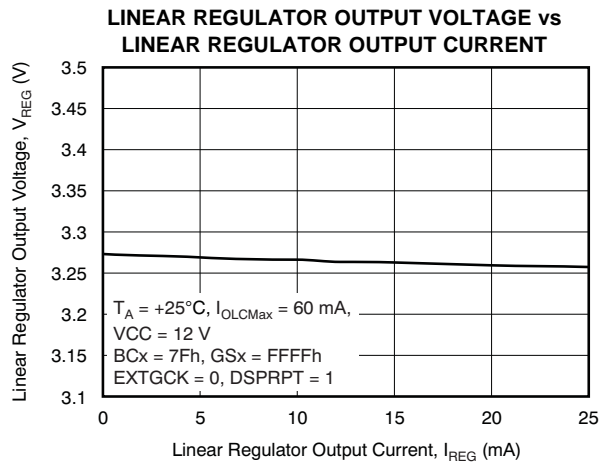

Figure 19.

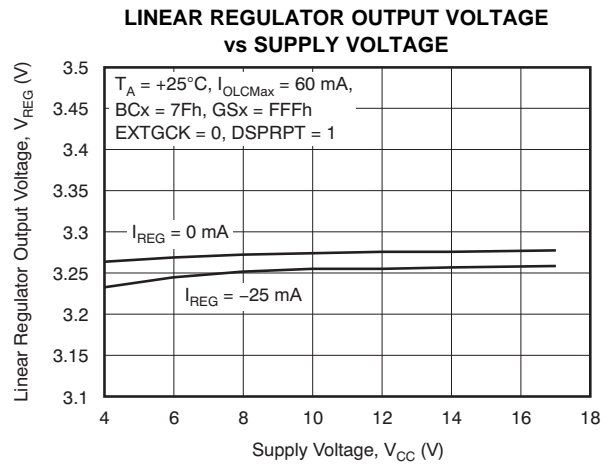

Figure 20.

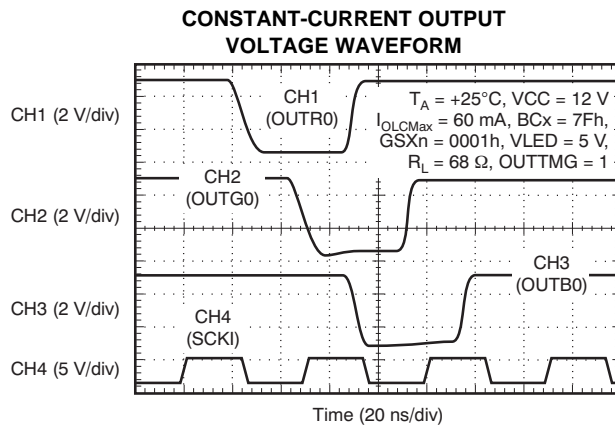

Figure 21.

## APPLICATION INFORMATION

### MAXIMUM CONSTANT SINK CURRENT SETTING

The maximum constant sink current value for each channel,  $I_{OLCMax}$ , is programmed through a single resistor,  $R_{IREF}$ , placed between IREF and GND. The desired value can be calculated with [Equation 1](#):

$$R_{IREF} (k\Omega) = \frac{V_{IREF} (V)}{I_{OLCMax} (mA)} \times 41$$

Where:

$V_{IREF}$  = the internal reference voltage on the IREF pin (1.21 V, typically, when the the global brightness control data are at maximum),

$I_{OLCMax}$  = 2 mA to 60 mA. (1)

$I_{OLCMax}$  is the maximum current for each output. Each output sinks the  $I_{OLCMax}$  current when it is turned on and global brightness control data (BC) are set to the maximum value of 7Fh (127d).

$R_{IREF}$  must be between 0.82 k $\Omega$  and 24.8 k $\Omega$  to hold  $I_{OLCMax}$  between 60 mA (typical) and 2 mA (typical). Otherwise, the output may be unstable. Output currents lower than 2 mA can be achieved by setting  $I_{OLCMax}$  to 2 mA or higher and then using global brightness control to lower the output current. The constant-current sink values for specific external resistor values are shown in [Figure 11](#) and [Table 1](#).

**Table 1. Maximum Constant-Current versus External Resistor Value**

$I_{OLCMax}$ (mA)	$R_{IREF}$ (k $\Omega$ , Typical)
60	0.827
55	0.902
50	0.992
45	1.1
40	1.24
35	1.42
30	1.65
25	1.98
20	2.48
15	3.31
10	4.96
5	9.92
2	24.8

## GLOBAL BRIGHTNESS CONTROL (BC) FUNCTION (SINK CURRENT CONTROL)

The TLC59711 has the capability to adjust all output currents of each color group (OUTR0-3, OUTG0-3, and OUTB0-3) to the same current value. This function is called *global brightness (BC) control*. The BC data are seven bits long, which allows each color group output current to be adjusted in 128 steps from 0% to 100% of the maximum output current,  $I_{OLCMax}$ . The BC data are set via the serial interface. When the BC data are changed, the output current is changed immediately.

When the IC is powered on, all outputs are forced off by BLANK (bit 213). BLANK initializes in the data latch but the data in the 224-bit shift register and the 218-bit data latch are not set to a default value, except for the BLANK bit. Therefore, BC data must be written to the data latch when BLANK is set to '0'.

Equation 2 determines each color group maximum output sink current:

$$I_{OUT} \text{ (mA)} = I_{OLCMax} \text{ (mA)} \times \left( \frac{BCX}{127d} \right)$$

Where:

$I_{OLCMax}$  = the maximum channel current for each channel determined by  $R_{IREF}$

BC = the global brightness control value in the data latch for the specific color group

(BCX = 0d to 127d, X = R/G/B)

(2)

Table 2 summarizes the BC data value versus the output current ratio and set current value.

**Table 2. BC Data versus Current Ratio and Set Current Value**

BC DATA (Binary)	BC DATA (Decimal)	BC DATA (Hex)	OUTPUT CURRENT RATIO TO $I_{OLCMax}$ (% , Typical)	60 mA $I_{OLCMax}$ (mA, Typical)	2 mA $I_{OLCMax}$ (mA, Typical)
000 0000	0	00	0	0	0
000 0001	1	01	0.8	0.47	0.02
000 0010	2	02	1.6	0.94	0.03
—	—	—	—	—	—
111 1101	125	7D	98.4	59.06	1.97
111 1110	126	7E	99.2	59.53	1.98
111 1111	127	7F	100	60	2



## GRAYSCALE (GS) FUNCTION (PWM CONTROL)

The TLC59711 can adjust the brightness of each output channel using the enhanced spectrum pulse width modulation (ES-PWM) control scheme. The PWM bit length for each output is 16 bits. The use of the 16-bit length results in 65536 brightness steps from 0% to 100% brightness.

The PWM operation for all color groups is controlled by a 16-bit grayscale (GS) counter. The GS counter increments on each rising or falling edge of the external or internal GS reference clock that is selected by OUTTMG (bit 217) and EXTGCK (bit 216) in the data latch. When the external GS clock is selected, the GS counter uses the SCKI clock as the grayscale clock. The GS counter is reset to 0000h and all outputs are forced off when BLANK (bit 213) is set to '1' in the data latch and the counter value is held at '0' while BLANK is '1', even if the GS reference clock is toggled in between.

**Equation 3** calculates each output (OUTXn) total on-time ( $t_{OUT\_ON}$ ):

$$t_{OUT\_ON} \text{ (ns)} = t_{GSCLK} \text{ (ns)} \times GSXn$$

Where:

$t_{GSCLK}$  = one period of the selected GS reference clock

(internal clock = 100ns typical, external clock = the period of SCKI)

GSXn = the programmed GS value for OUTXn (0d to 65535d) (3)

**Table 3** summarizes the GS data values versus the output total on-time and duty cycle. When the IC is powered up, BLANK (bit 213) is set to '1' to force all outputs off; however, the 224-bit shift register and the 218-bit data latch are not set to default values. Therefore, the GS data must be written to the data latch when BLANK (bit 213) is set to '0'.

**Table 3. Output Duty Cycle and Total On-Time versus GS Data**

GS DATA (decimal)	GS DATA (hex)	ON-TIME DUTY (%)	GS DATA (decimal)	GS DATA (hex)	ON-TIME DUTY (%)
0	0	0	32768	8000	50.001
1	1	0.002	32769	8001	50.002
2	2	0.003	32770	8002	50.004
3	3	0.005	32771	8003	50.005
—	—	—	—	—	—
8191	1FFF	12.499	40959	9FFF	62.499
8192	2000	12.5	40960	A000	62.501
8193	2001	12.502	40961	A001	62.502
—	—	—	—	—	—
16383	3FFF	24.999	49149	BFFF	74.997
16384	4000	25	49150	C000	74.998
16385	4001	25.002	49151	C001	75
—	—	—	—	—	—
24575	5FFF	37.499	57343	DFFF	87.5
24576	6000	37.501	57344	E000	87.501
24577	6001	37.502	57345	E001	87.503
—	—	—	—	—	—
32765	7FFD	49.996	65533	FFFD	99.997
32766	7FFE	49.998	65534	FFFE	99.998
32767	7FFF	49.999	65535	FFFF	100

## ENHANCED SPECTRUM (ES) PWM CONTROL

Enhanced spectrum (ES) PWM has the total display period divided into 128 display segments. The total display period refers the period between the first grayscale clock input to the 65536th grayscale clock input after BLANK (bit 213) is set to '0'. Each display period has 512 grayscale values, maximum. Each output on-time changes depending on the grayscale data. Refer to [Table 4](#) for sequence information and [Figure 22](#) for timing information.

**Table 4. ES-PWM Drive Turn-On Time Length**

GS DATA (dec)	GS DATA (hex)	OUTn DRIVER OPERATION
0	0000h	Does not turn on
1	0001h	Turns on during one GS clock period in the 1st display period
2	0002h	Turns on during one GS clock period in the 1st and 65th display period
3	0003h	Turns on during one GS clock period in the 1st, 33rd, and 65th display period
4	0004h	Turns on during one GS clock period in the 1st, 33rd, 65th, and 97th display period
5	0005h	Turns on during one GS clock period in the 1st, 17th, 33rd, 65th, and 97th display period
6	0006h	Turns on during one GS clock period in the 1st, 17th, 33rd, 65th, 81st, and 97th display period
—	—	The number of display periods that OUTXn is turned on during one GS clock is incremented by the GS data increasing in the following order. The order of display periods that the output turns on are: 1, 65, 33, 97, 17, 81, 49, 113, 9, 73, 41, 105, 25, 89, 57, 121, 5, 69, 37, 101, 21, 85, 53, 117, 13, 77, 45, 109, 29, 93, 61, 125, 3, 67, 35, 99, 19, 83, 51, 115, 11, 75, 43, 107, 27, 91, 59, 123, 7, 71, 39, 103, 23, 87, 55, 119, 15, 79, 47, 111, 31, 95, 63, 127, 2, 66, 34, 98, 18, 82, 50, 114, 10, 74, 42, 106, 26, 90, 58, 122, 6, 70, 38, 102, 22, 86, 54, 118, 14, 78, 46, 110, 30, 94, 62, 126, 4, 68, 36, 100, 20, 84, 52, 116, 12, 76, 44, 108, 28, 92, 60, 124, 8, 72, 40, 104, 24, 88, 56, 120, 16, 80, 48, 112, 32, 96, 64, and 128.
127	007Fh	Turns on during one GS clock period in the 1st to 127th display period, but does not turn on in the 128th display period
128	0080h	Turns on during one GS clock period in all display periods (1st to 128th)
129	0081h	Turns on during two GS clock periods in the 1st display period and one GS clock period in the next display period
—	—	The number of display periods where OUTn is turned on for two GS clocks is incremented by the increased GS data similar to the previous case where the GS value is 1 through 127
255	00FFh	Turns on during two GS clock periods in the 1st to 127th display period, but only turns on during one GS clock period in the 128th display period
256	0100h	Turns on during two GS clock periods in all display periods (1st to 128th)
257	0101h	Turns on during three GS clock periods in the 1st display period and two GS clock periods in the next display period
—	—	Display periods with OUTn turned on is incremented by the increased GS data similar to 0101h operation
65478	FEFFh	Turns on during 511 GS clock periods in the 1st to 127th display period, but only turns on 510 GS clock periods in the 128th display period
65280	FF00h	Turns on during 511 GS clock periods in all display periods (1st to 128th)
65281	FF01h	Turns on during 512 GS clock periods in the 1st display period and 511 GS clock periods in the 2nd to 128th display periods
—	—	—
65534	FFFEh	Turns on during 512 GS clock periods in the 1st to 63th and 65th to 127th display periods, and turns on 511 GS clock periods in the 64th and 128th display periods
65535	FFFFh	Turns on during 512 GS clock periods in the 1st to 127th display period, but only turns on 511 GS clock periods in the 128th display period

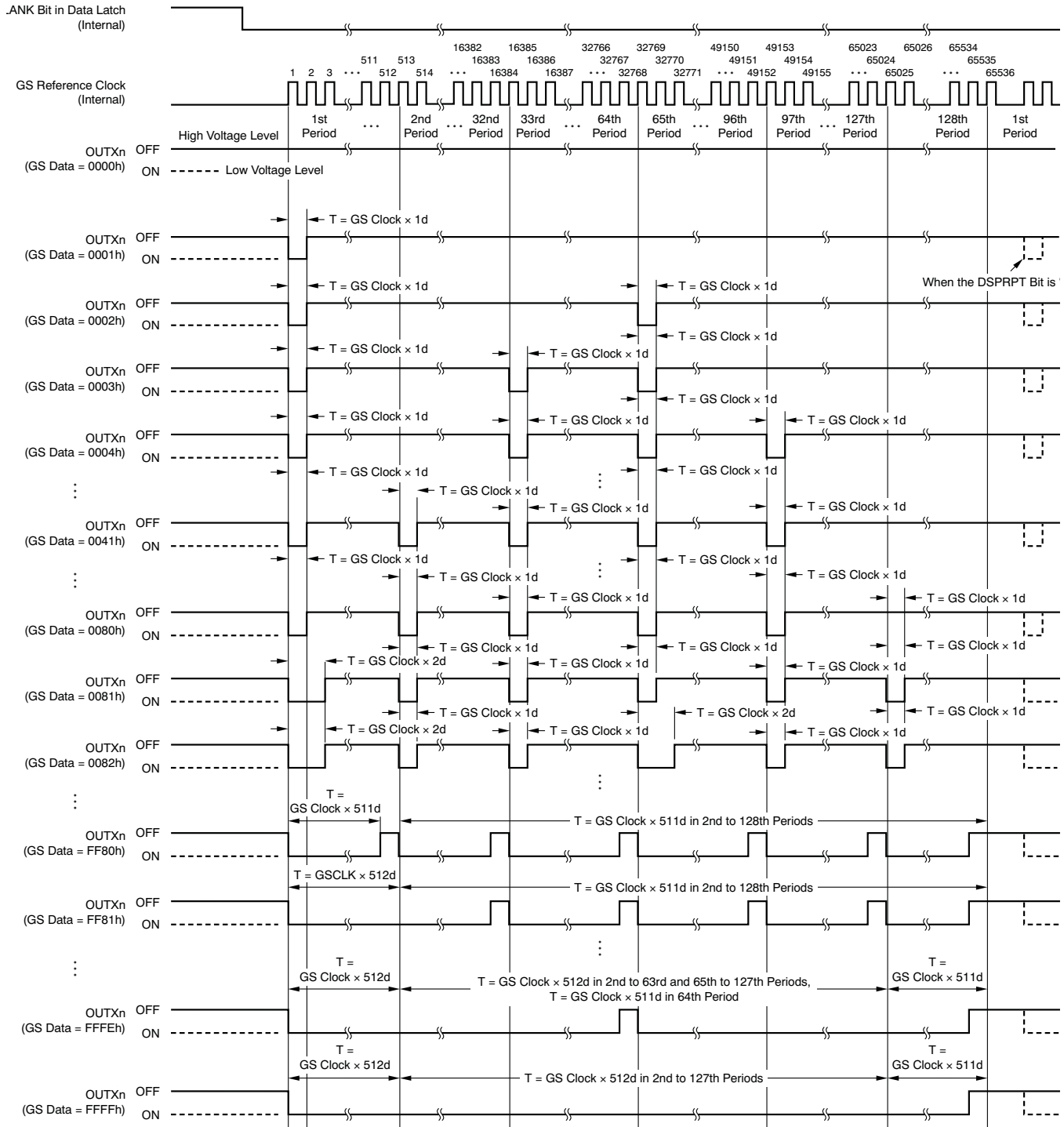
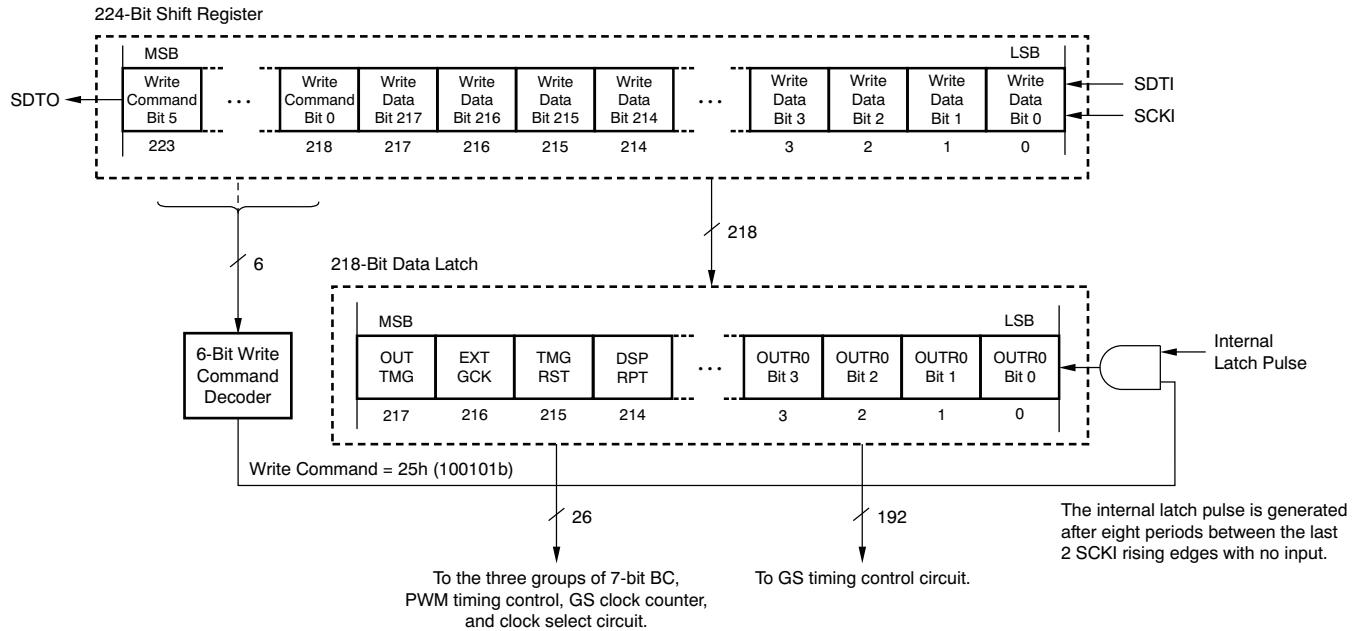

Figure 22. ES-PWM Operation

## REGISTER AND DATA LATCH CONFIGURATION

The TLC59711 has a 224-bit shift register and a 218-bit data latch that set grayscale (GS) data, global brightness control (BC), and function control (FC) data into the device. When the internal latch pulse is generated and the data of the six MSBs in the shift register are 25h, the 218 following data bits in the shift register are copied into the 218-bit data latch. If the data of the six MSBs is not 25h, the 218 data bits are not copied into the 218-bit data latch. The data in the data latch are used for GS, BC, and FC functions. [Figure 23](#) shows the shift register and the data latch configuration.



**Figure 23. Common Shift Register and Control Data Latch Configuration**

### 224-Bit Shift Register

The 224-bit shift register is used to input data from the SDTI pin with the SCKI clock into the TLC59711. The shifted data in this register is used for GS, BC, and FC. The six MSBs are used for the write command. The LSB of the register is connected to the SDTI pin and the MSB is connected to the SDTO pin. On each SCKI rising edge, the data on SDTI are shifted into the register LSB and all 224 bits are shifted towards the MSB. The register MSB is always connected to SDTO. When the device is powered up, the data in the 224-bit shift register is not set to any default value.

### 218-Bit Data Latch

The 218-bit data latch is used to latch the GS, BC, and FC data. The 218 LSBs in the 244-bit shift register are copied to the data latch when the internal latch pulse is generated with the 6-bit write command, 25h (100101b). When the device is powered up, the data in the latch are not reset except for BLANK (bit 213) which is set to '1' to force all outputs off. Therefore, GS, BC, and FC data must be set to the proper values before BLANK is set to '0'. The 218-bit data latch configuration is shown in [Figure 24](#) and the data bit assignment is shown in [Table 5](#).

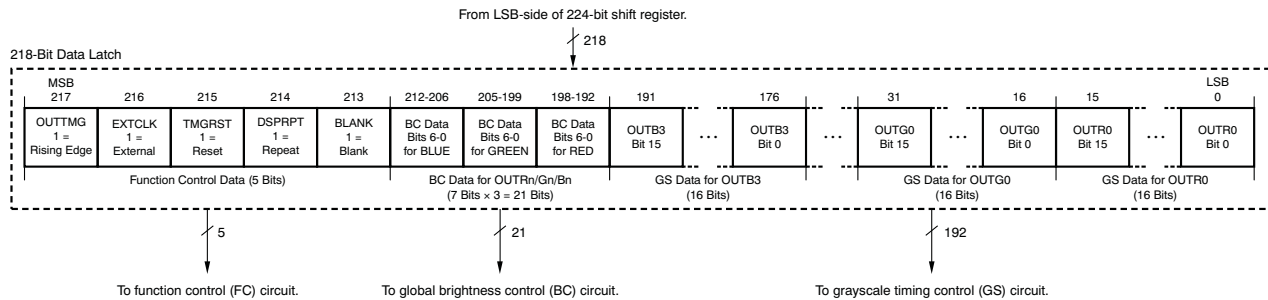
**Figure 24. 218-Bit Data Latch Configuration**
**Table 5. Data Latch Bit Assignment**

BIT NUMBER	BIT NAME	CONTROLLED CHANNEL/FUNCTIONS
15-0	GSR0	GS data bits 15 to 0 for OUTR0
31-16	GSG0	GS data bits 15 to 0 for OUTG0
47-32	GSB0	GS data bits 15 to 0 for OUTB0
63-48	GSR1	GS data bits 15 to 0 for OUTR1
79-64	GSG1	GS data bits 15 to 0 for OUTG1
95-80	GSB1	GS data bits 15 to 0 for OUTB1
111-96	GSR2	GS data bits 15 to 0 for OUTR2
127-112	GSG2	GS data bits 15 to 0 for OUTG2
143-128	GSB2	GS data bits 15 to 0 for OUTB2
159-144	GSR3	GS data bits 15 to 0 for OUTR3
175-160	GSG3	GS data bits 15 to 0 for OUTG3
191-176	GSB3	GS data bits 15 to 0 for OUTB3
198-192	BCR	BC data bits 6 to 0 for OUTR0-3
205-199	BCG	BC data bits 6 to 0 for OUTG0-3
212-206	BCB	BC data bits 6 to 0 for OUTB0-3
213	BLANK	Constant-current output enable bit in FC data (0 = output control enabled, 1 = blank). When this bit is '0', all constant-current outputs (OUTR0-OUTB3) are controlled by the GS PWM timing controller. When this bit is '1', all constant-current outputs are forced off. The GS counter is reset to '0', and the GS PWM timing controller is initialized. When the IC is powered on, this bit is set to '1'.
214	DSPRPT	Auto display repeat mode enable bit in FC data (0 = disabled, 1 = enabled). When this bit is '0', the auto repeat function is disabled. Each constant-current output is only turned on once, according the GS data after BLANK is set to '0' or after the internal latch pulse is generated with the TMGRST bit set to '1'. When this bit is '1', each output turns on and off according to the GS data every 65536 GS reference clocks.
215	TMGRST	Display timing reset mode enable bit in FC data (0 = disabled, 1 = enabled). When this bit is '1', the GS counter is reset to '0' and all constant-current outputs are forced off when the internal latch pulse is generated for data latching. This function is the same when BLANK is set to '0'. Therefore, BLANK does not need to be controlled by an external controller when this mode is enabled. When this bit is '0', the GS counter is not reset and no output is forced off even if the internal latch pulse is generated.
216	EXTGCK	GS reference clock select bit in FC data (0 = internal oscillator clock, 1 = SCKI clock). When this bit is '1', PWM timing refers to the SCKI clock. When this bit is '0', PWM timing refers to the internal oscillator clock.
217	OUTTMG	GS reference clock edge select bit for OUTXn on-off timing control in FC data (0 = falling edge, 1 = rising edge). When this bit is '1', OUTXn are turned on or off at the rising edge of the selected GS reference clock. When this bit is '0', OUTXn are turned on or off at the falling edge of the selected clock.

### INTERNAL LATCH PULSE GENERATION TIMING

The internal latch pulse is generated when the SCKI rising edge does not change for 8x the period between the last SCKI rising edge and the second to last SCKI rising edge if the data of the six MSBs in the 244-bit shift register are the command code 25h. The generation timing changes as a result of the SCKI frequency with the time range between 16384 times the internal oscillator period (2.74ms), maximum, and 8x the internal oscillator period (666 ns), minimum. Figure 25 shows the internal latch pulse generation timing.

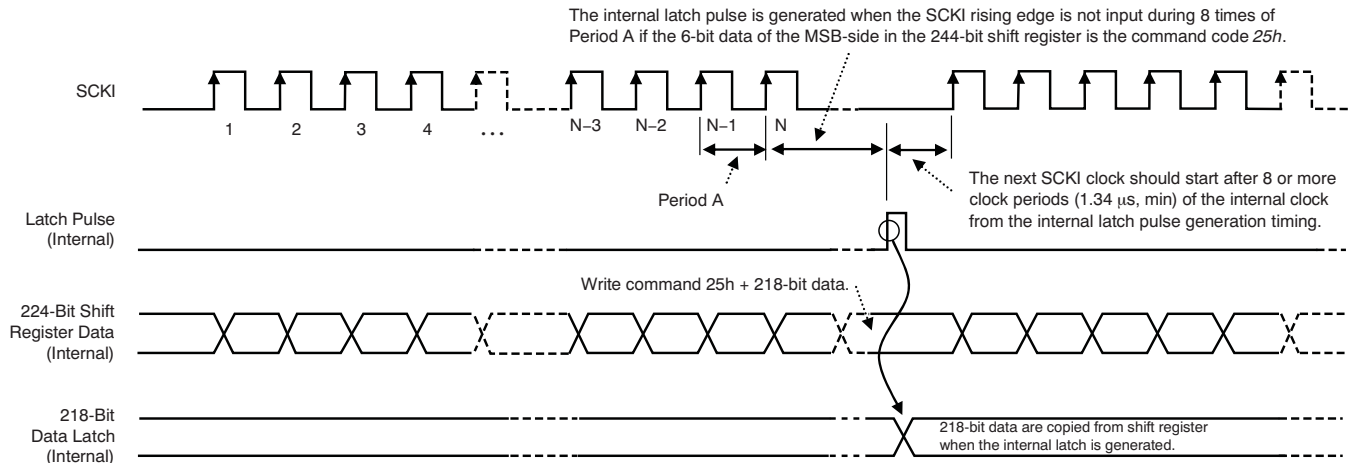

Figure 25. Data Latch Pulse Generation Timing

### AUTO DISPLAY REPEAT FUNCTION

This function repeats the total display period without a BLANK bit change, as long as the GS reference clock is available. This function can be enabled or disabled with DSPRPT (bit 214) in the data latch. When the DSPRPT bit is '1', this function is enabled and the entire display period repeats without a BLANK bit data change. When the DSPRPT bit is '0', this function is disabled and the entire display period executes only once after the BLANK bit is set to '0' or the internal latch pulse is generated when the display timing reset function is enabled. Figure 26 shows the auto display repeat operation timing.

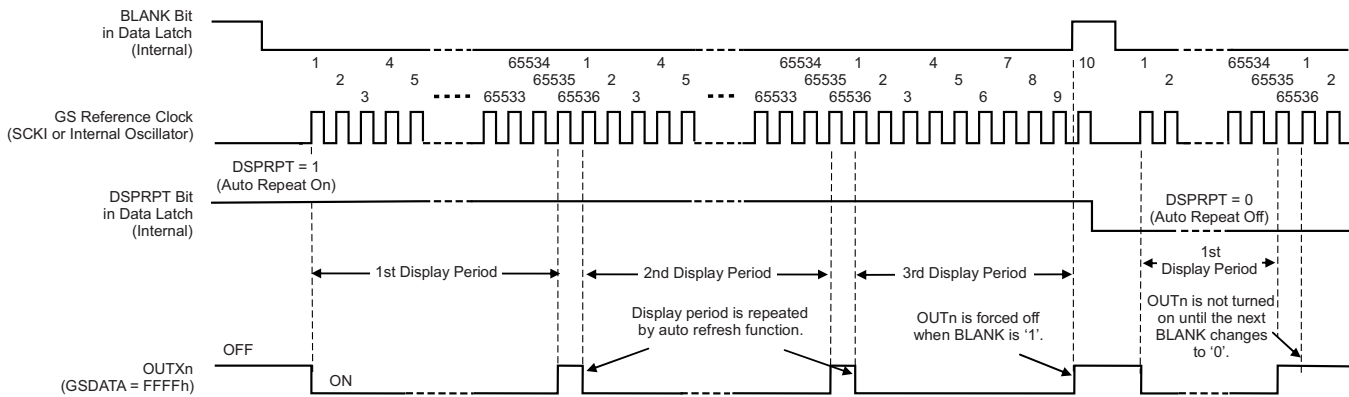

Figure 26. Auto Repeat Display Function

## DISPLAY TIMING RESET FUNCTION

This function allows the display timing to be initialized using the internal latch pulse, as shown in [Figure 27](#). This function can be enabled or disabled by TMGRST (bit 215) in the data latch. When the TMGRST bit is '1', the GS counter is reset to '0' and all outputs are forced off when the internal latch pulse is generated. This function is the same when the BLANK bit changes (such as from '0' to '1' and from '1' to '0'). Therefore, the BLANK bit does not need to be controlled from an external controller to restart the PWM control from the next GS reference clock rising edge. When this bit is '0', the GS counter is not reset and no output is forced off even if the internal latch pulse is generated. [Figure 27](#) shows the display timing reset operation.

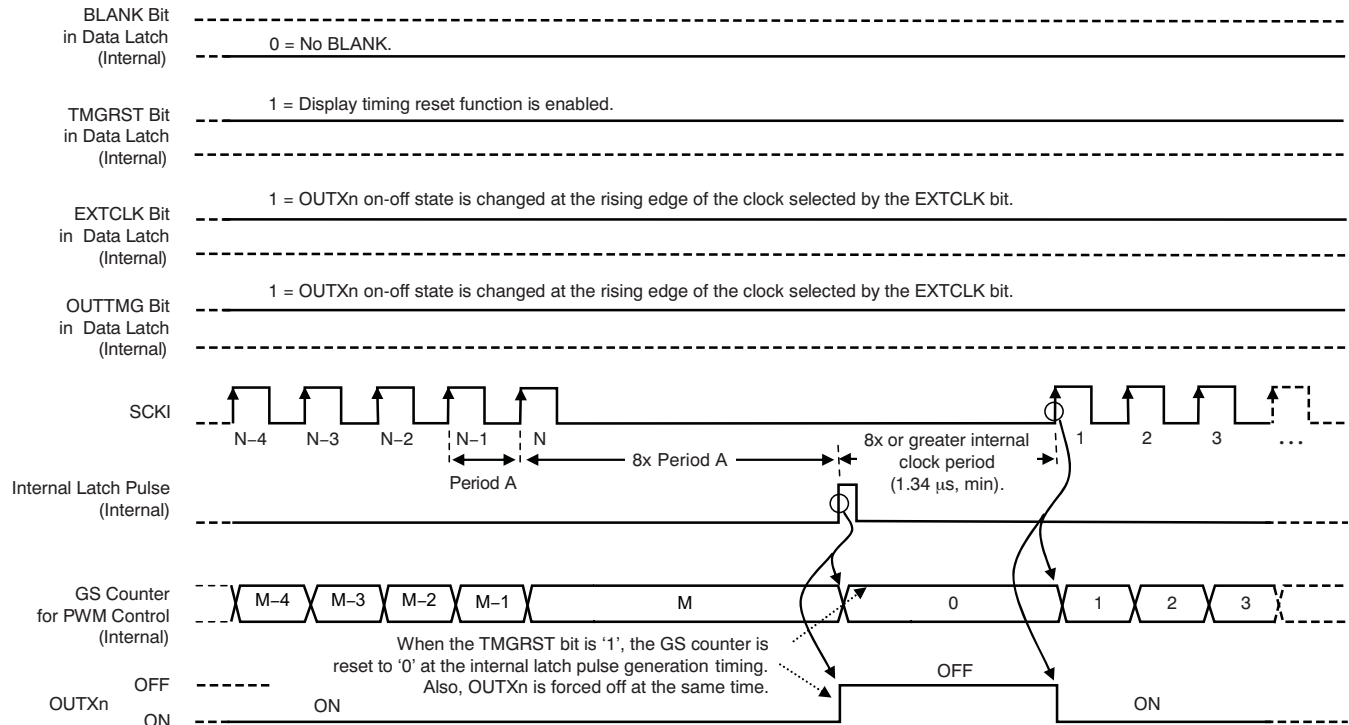
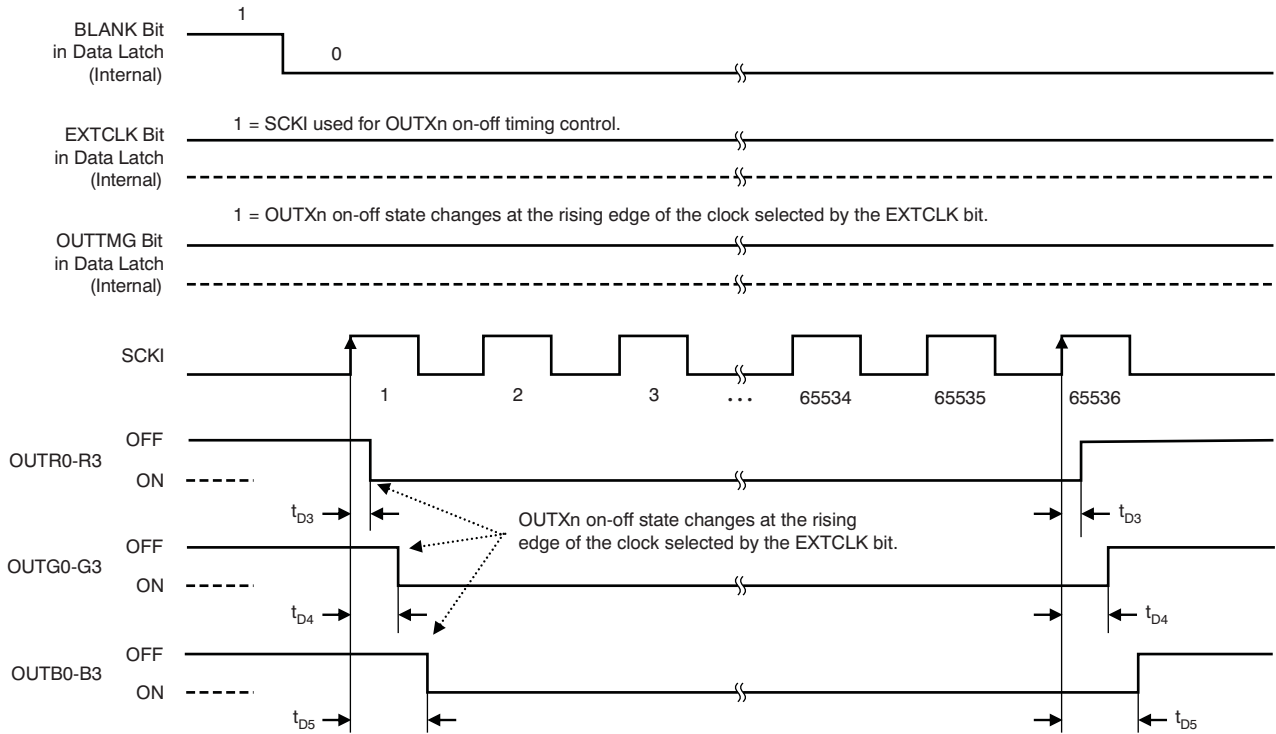

Figure 27. Display Timing Reset Function

## OUTPUT TIMING SELECT FUNCTION

This function selects the on-off change timing of the constant-current outputs (OUTXn) set by OUTTMG (bit 217) in the data latch. When this bit is '1', OUTXn are turned on or off at the rising edge of the selected GS reference clock. When this bit is '0', OUTXn are turned on or off at the falling edge of the selected clock. Electromagnetic interference (EMI) of the total system can be reduced using this bit setting. For example, when the odd number of devices in the system have this bit set to '0' and the even number of devices in the system have this bit set to '1', EMI is reduced because the devices change the OUTXn status at a deferent timing. [Figure 28](#) and [Figure 29](#) show the output switching timing when the OUTTMG bit is '1' and '0', respectively.



**Figure 28. Output On-Off Timing with Four-Channel Grouped Delay (OUTTMG = 1)**

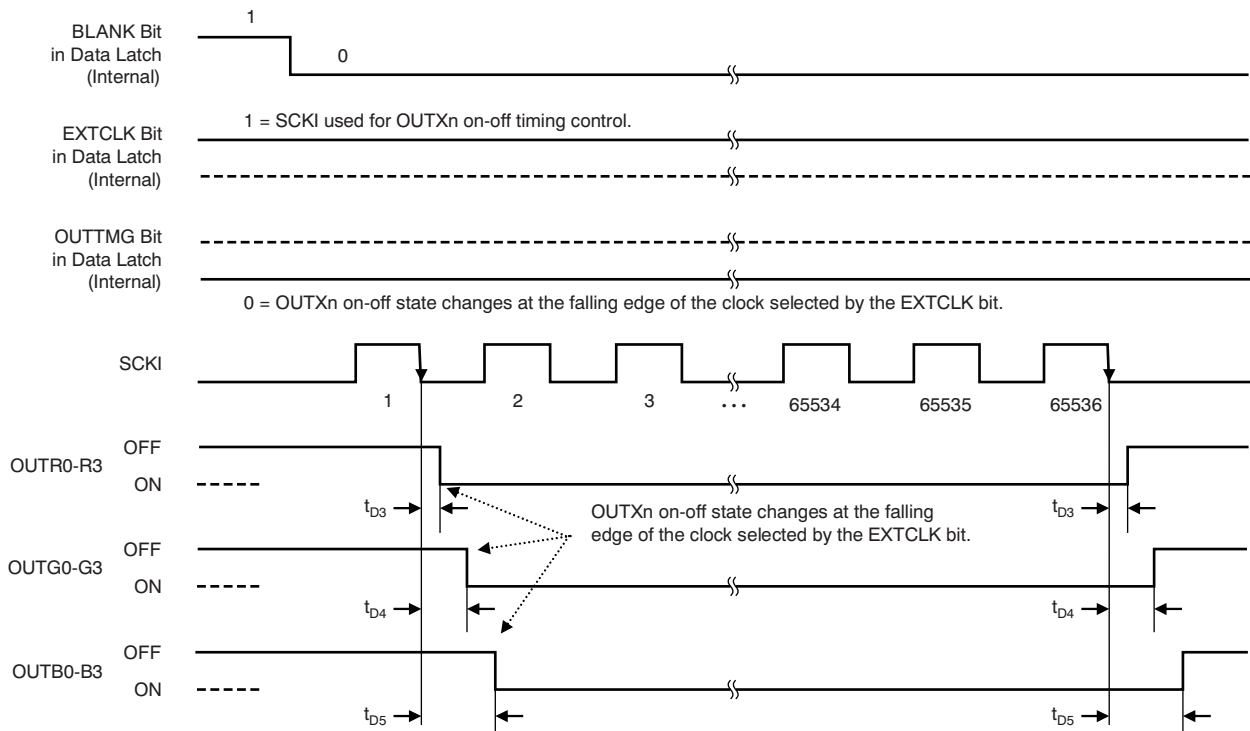

**Figure 29. Output On-Off Timing with Four-Channel Grouped Delay (OUTTMG = 0)**



## WATCHDOG TIMER FUNCTION

This function is enabled when SCKI clock is selected as GS reference clock by EXTGCK (bit 216) in the data latch. When EXTGCK bit is '1', if SCKI rising edge does not change for 8x the period between the last SCKI rising edge and the second to last SCKI rising edge with any accident, all OUTXn is forced off and GS clock counter is reset to "0" to avoid displaying unexpected image.

Figure 31 shows the watchdog operation timing when SCKI rising edge is not changed with EXTGCK bit is '1'.

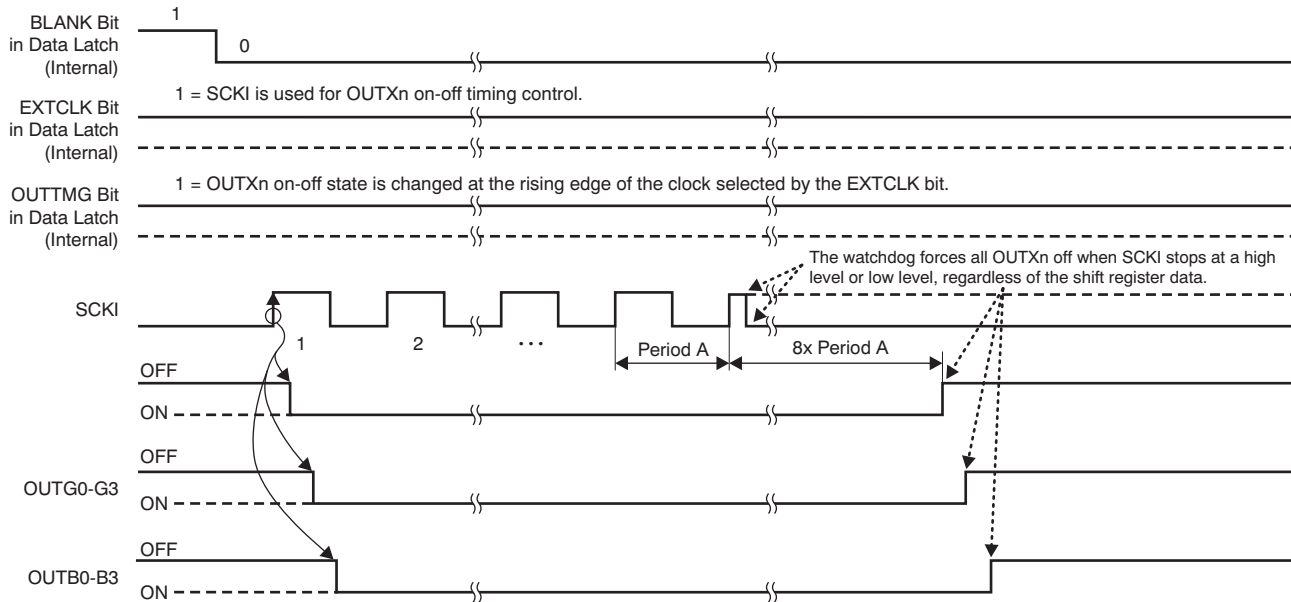

**Figure 30. Watchdog Operation Timing with no SCKI Clock Input (OUTTMG = 1)**

## THERMAL SHUTDOWN

The thermal shutdown (TSD) function turns off all IC constant-current outputs when the junction temperature ( $T_j$ ) exceeds the threshold ( $T_{TSD} = +165^\circ\text{C}$ , typ). When the junction temperature drops below ( $T_{TSD} - T_{HYS}$ ), the output control starts at the first GS clock in the next display period.

## NOISE REDUCTION

Large surge currents may flow through the IC and the board if all 12 outputs turn on simultaneously at the start of each GS cycle. These large current surges could induce detrimental noise and EMI into other circuits. The TLC59711 turns on the outputs for each color group independently with a 25 ns (typ) rise time. The output current sinks are grouped into three groups. The first group that is turned on/off are OUTR0-3; the second group that is turned on/off are OUTG0-3; and the third group is OUTB0-3. However, the state of each output is controlled by the selected GS clock; see the [Output Timing Select Function](#) section.

### HOW TO CONTROL THE TLC59711

To set each function mode, BC color, GS output, 6-bit write command, 5-bit FC data, 21-bit BC data for each color group, and 192-bit GS data for OUTXn, a total number of 224 bits must be written into the device. Figure 31 shows the 224-bit data packet configuration.

When *N* units of the TLC59711 are cascaded (as shown in Figure 32), *N* × 224 bits must be written from the controller into the first device to control all devices. The number of cascaded devices is not limited as long as the proper voltage is supplied to the device at VCC. The packets for all devices must be written again whenever the data in one packet is changed.

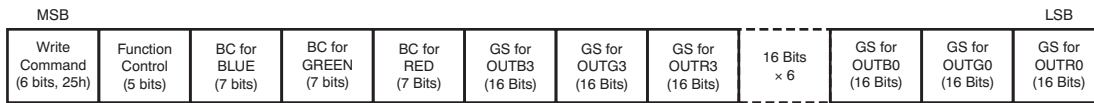

Figure 31. 224-Bit Data Packet Configuration

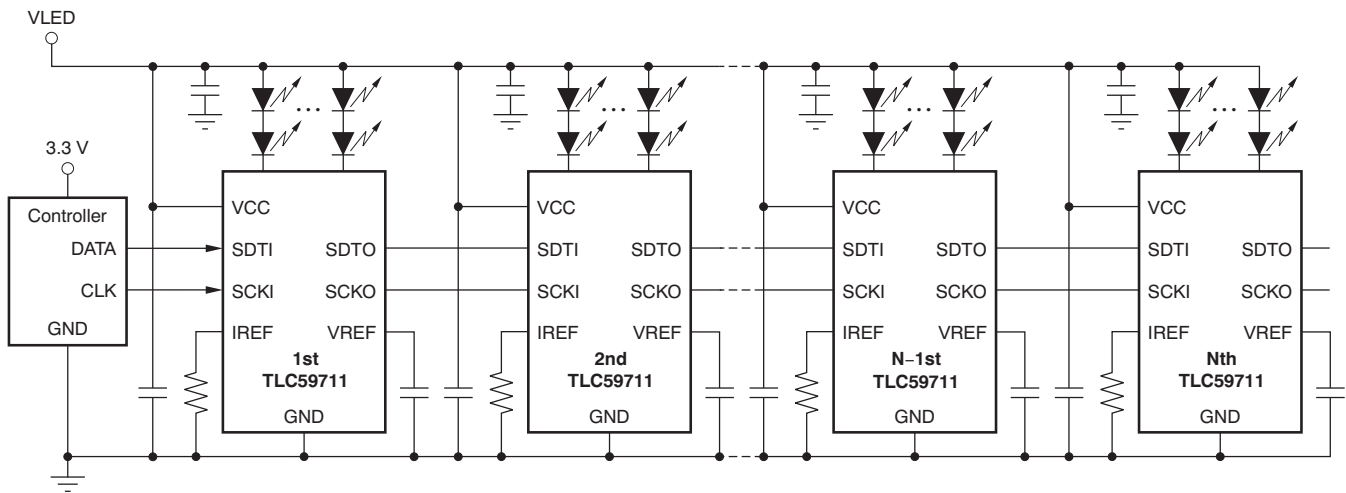
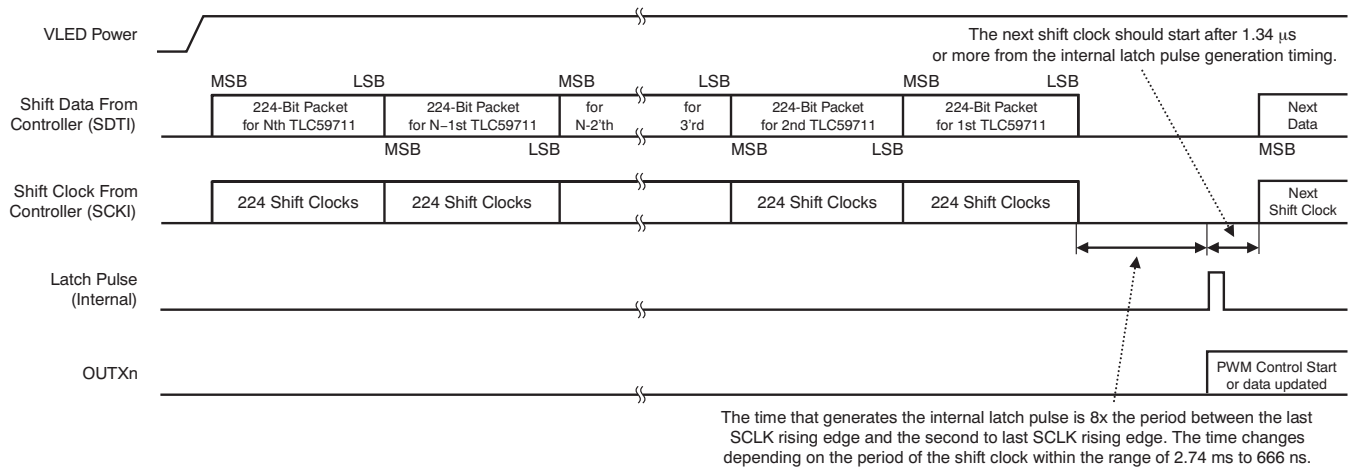

Figure 32. Cascading Connection of *N* TLC59711 Units

### Data Write and PWM Control with Internal Grayscale Clock Mode

When the EXTCLK bit is '0', the internal oscillator clock is used for PWM control of OUTXn (X = R/G/B and n = 0-3) as the GS reference clock. This mode is ideal for illumination applications that change the display image at low frequencies. The data and clock timing is shown in Figure 9 and Figure 33. A writing procedure for the function setting and display control follows:

1. Power up VCC (VLED); all OUTXn are off because BLANK is set to '1'.
2. Write the 224-bit data packet (with MSB bit first) for the Nth TLC59711 using the SDTI and SCKI signals. The first six bits of the 224-bit data packet are used as the write command. The write command must be 25h (100101b); otherwise, the 218-bit data in the 224-bit shift register are not copied to the 218-bit data latch. The EXTCLK bit must be set to '0' for the internal oscillator mode. Also, the DSPRPT bit should be set to '1' to repeat the PWM timing control and BLANK set to '0' to start the PWM control.
3. Write the 224-bit data packet for the (N – 1) TLC59711 without delay after step 2.
4. Repeat the data write sequence until all TLC59711s have data. The total shift clock count (SCKI) is now 224 × N. After all device data are written, stop the SCKI at a high or low level for 8x the period between the last SCKI rising edge and the second to last SCKI rising edge. Then the 218 LSBs in the 224-bit shift register are copied to the 218-bit data latch in all devices and the PWM control is started or updated at the same time.

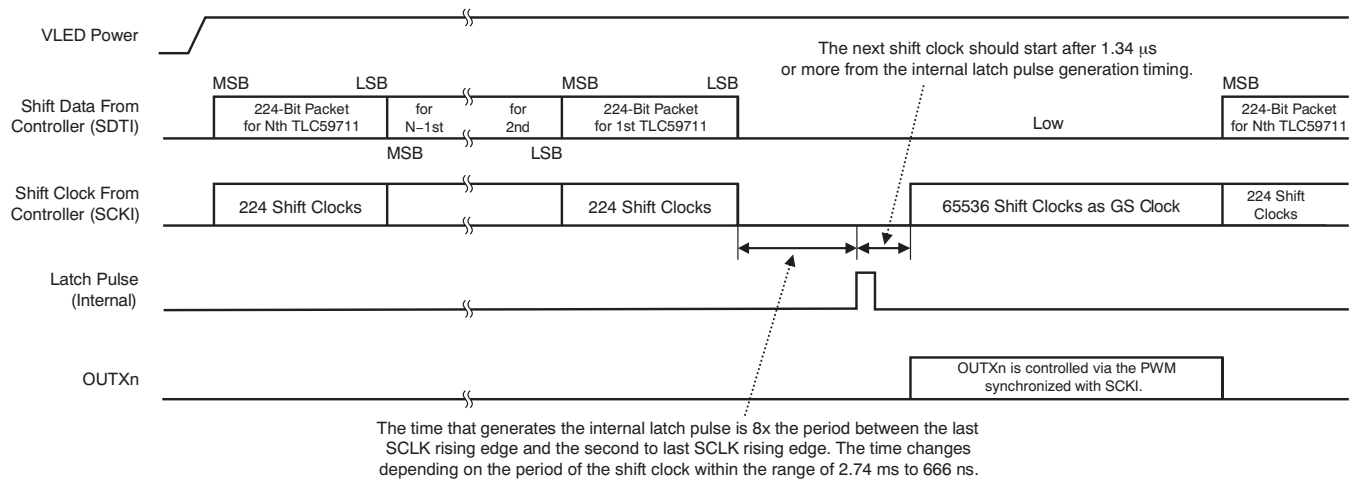

**Figure 33. Data Packet and Display Start/Update Timing 1 (Internal Oscillator Mode)**

## Data Write and PWM Control with External Grayscale Clock Mode

When the EXTCLK bit is '1', the data shift clock (SCKI) is used for PWM control of OUTXn (X = R/G/B and n = 0-3) as the GS reference clock. This mode is ideal for video image applications that change the display image with high frequencies or for certain display applications that must synchronize all TLC59711s. The data and clock timing are shown in Figure 9 and Figure 34. A writing procedure for the display data and display timing control follows:

1. Power- up VCC (VLED); all OUTXn are off because BLANK is set to '1'.
2. Write the 224-bit data packet MSB-first for the Nth TLC59711 using the SDTI and SCKI signals. The first six bits of the 224-bit data packet are used as the write command. The write command must be 25h (100101b); otherwise, the 218-bit data in the 224-bit shift register are not copied to the 218-bit data latch. The EXTCLK bit must be set to '1' for the external oscillator mode. Also, the DSPRPT bit should be set to '0' so that the PWM control is not repeated, the TMGRST bit should be set to '1' to reset the PWM control timing at the internal latch pulse generation, and BLANK must be set to '0' to start the PWM control.
3. Write the 224-bit data for the (N – 1) TLC59711 without delay after step 2.
4. Repeat the data write sequence until all TLC59711s have data. The total shift clock count (SCKI) is  $224 \times N$ . After all device data are written, stop the SCKI at a high or low level for  $8 \times$  the period between the last SCKI rising edge and the second to last SCKI rising edge. Then the 218 LSBs in the 224-bit shift register are copied to the 218-bit data latch in all devices.
5. To start the PWM control, send one pulse of the SCKI clock with SDTI low after  $1.34 \mu\text{s}$  or more from step 4. The OUTXn are turned on when the output GS data are not 0000h.
6. Send the remaining 65535 SCKI clocks with SDTI low. Then the PWM control for OUTXn is synchronized with the SCKI clock and one display period is finished with a total of 65536 SCKI clock periods.
7. Repeat step 2 to step 6 for the next display period.



**Figure 34. Data Packet and Display Start/Update Timing 2 (External Clock Mode)**

There is another control procedure that is recommended for a long chain of cascaded devices. The data and clock timings are shown in [Figure 9](#) and [Figure 35](#). When 256 TLC59711 units are cascaded, use the following procedure:

1. Power up VCC (VLED); all OUTXn are off because BLANK is set to '1'.
2. Write the 224-bit data packet MSB-first for the 256th TLC59711 using the SDTI and SCKI signals. The EXTCLK bit must be set to '1' for the external oscillator mode. Also, the DSPRPT bit should be set to '0' so that the PWM control does not repeat, the TMGRST bit should be set to '1' to reset the PWM control timing with the internal latch pulse, and BLANK must be set to '0' to start the PWM control.
3. Repeat the data write sequence for all TLC59711s. The total shift clock count (SCKI) is 57344 (224 × 256). After all device data are written, stop the SCKI signal at a high or low level for eight or more periods between the last SCKI rising edge and the second to last SCKI rising edge. Then the 218 LSBs in the 224-bit shift register are copied to the 218-bit data latch in all devices.
4. To control the PWM, send 8192 SCKI clock periods with SDTI low after 1.34µs or more from step 3 (or step 7). These 8192 clock periods are used for the OUTXn PWM control.
5. Write the new 224-bit data packets to the 256th to first TLC59711s for the next display with 256 × 224 SCKI clock for a total of 57344 clocks. The PWM control for OUTXn remains synchronized with the SCKI clock and one display period is finished with a total of 65536 SCKI clocks. The SCKI clock signal is therefore used for PWM control and, at the same time, to write data into the shift registers of all cascaded parts.
6. Stop the SCKI signal at a high or low level for eight or more periods between the last SCKI rising edge and the second to last SCKI rising edge. Then the 218-bit LSBs in the 224-bit shift register are copied to the 218-bit data latch in all devices.
7. Repeat step 4 to step 6 for the next display periods.

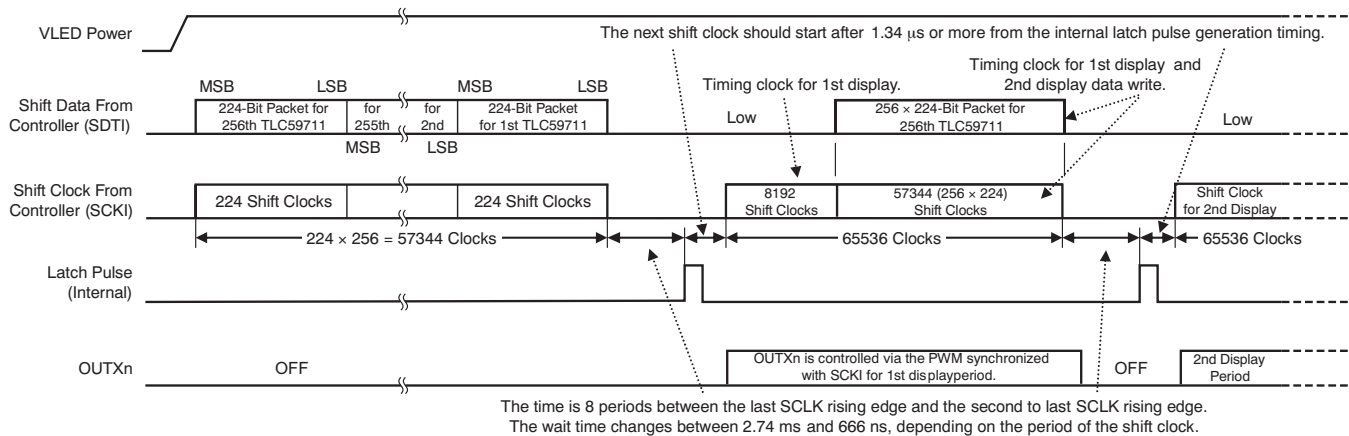

**Figure 35. Data Packet and Display Start/Update Timing 3  
(External Clock Mode with 256 Cascaded Devices)**

### REVISION HISTORY

NOTE: Page numbers for previous revision may differ from the page numbers in the current version.

Changes from Original (October 2011) to Revision A	Page
• Fixed typo in last row of <a href="#">Table 5</a> .....	21
• Changed <a href="#">Figure 26</a> .....	22

**PACKAGING INFORMATION**

Orderable Device	Status (1)	Package Type	Package Drawing	Pins	Package Qty	Eco Plan (2)	Lead/Ball Finish	MSL Peak Temp (3)	Op Temp (°C)	Top-Side Markings (4)	Samples
TLC59711PWP	ACTIVE	HTSSOP	PWP	20	70	Green (RoHS & no Sb/Br)	CU NIPDAU	Level-2-260C-1 YEAR	-40 to 85	TLC59711	<a href="#">Samples</a>
TLC59711PWPR	ACTIVE	HTSSOP	PWP	20	2000	Green (RoHS & no Sb/Br)	CU NIPDAU	Level-2-260C-1 YEAR	-40 to 85	TLC59711	<a href="#">Samples</a>

(1) The marketing status values are defined as follows:

**ACTIVE:** Product device recommended for new designs.

**LIFEBUY:** TI has announced that the device will be discontinued, and a lifetime-buy period is in effect.

**NRND:** Not recommended for new designs. Device is in production to support existing customers, but TI does not recommend using this part in a new design.

**PREVIEW:** Device has been announced but is not in production. Samples may or may not be available.

**OBSOLETE:** TI has discontinued the production of the device.

(2) Eco Plan - The planned eco-friendly classification: Pb-Free (RoHS), Pb-Free (RoHS Exempt), or Green (RoHS & no Sb/Br) - please check <http://www.ti.com/productcontent> for the latest availability information and additional product content details.

**TBD:** The Pb-Free/Green conversion plan has not been defined.

**Pb-Free (RoHS):** TI's terms "Lead-Free" or "Pb-Free" mean semiconductor products that are compatible with the current RoHS requirements for all 6 substances, including the requirement that lead not exceed 0.1% by weight in homogeneous materials. Where designed to be soldered at high temperatures, TI Pb-Free products are suitable for use in specified lead-free processes.

**Pb-Free (RoHS Exempt):** This component has a RoHS exemption for either 1) lead-based flip-chip solder bumps used between the die and package, or 2) lead-based die adhesive used between the die and leadframe. The component is otherwise considered Pb-Free (RoHS compatible) as defined above.

**Green (RoHS & no Sb/Br):** TI defines "Green" to mean Pb-Free (RoHS compatible), and free of Bromine (Br) and Antimony (Sb) based flame retardants (Br or Sb do not exceed 0.1% by weight in homogeneous material)

(3) MSL, Peak Temp. -- The Moisture Sensitivity Level rating according to the JEDEC industry standard classifications, and peak solder temperature.

(4) Multiple Top-Side Markings will be inside parentheses. Only one Top-Side Marking contained in parentheses and separated by a "~" will appear on a device. If a line is indented then it is a continuation of the previous line and the two combined represent the entire Top-Side Marking for that device.

**Important Information and Disclaimer:** The information provided on this page represents TI's knowledge and belief as of the date that it is provided. TI bases its knowledge and belief on information provided by third parties, and makes no representation or warranty as to the accuracy of such information. Efforts are underway to better integrate information from third parties. TI has taken and continues to take reasonable steps to provide representative and accurate information but may not have conducted destructive testing or chemical analysis on incoming materials and chemicals. TI and TI suppliers consider certain information to be proprietary, and thus CAS numbers and other limited information may not be available for release.

In no event shall TI's liability arising out of such information exceed the total purchase price of the TI part(s) at issue in this document sold by TI to Customer on an annual basis.

## TAPE AND REEL INFORMATION



### QUADRANT ASSIGNMENTS FOR PIN 1 ORIENTATION IN TAPE



\*All dimensions are nominal

Device	Package Type	Package Drawing	Pins	SPQ	Reel Diameter (mm)	Reel Width W1 (mm)	A0 (mm)	B0 (mm)	K0 (mm)	P1 (mm)	W (mm)	Pin1 Quadrant
TLC59711PWPR	HTSSOP	PWP	20	2000	330.0	16.4	6.95	7.1	1.6	8.0	16.0	Q1



TAPE AND REEL BOX DIMENSIONS



\*All dimensions are nominal

Device	Package Type	Package Drawing	Pins	SPQ	Length (mm)	Width (mm)	Height (mm)
TLC59711PWPR	HTSSOP	PWP	20	2000	367.0	367.0	38.0

# MECHANICAL DATA

PWP (R-PDSO-G20)

PowerPAD™ PLASTIC SMALL OUTLINE



- NOTES:
- All linear dimensions are in millimeters.
  - This drawing is subject to change without notice.
  - Body dimensions do not include mold flash or protrusions. Mold flash and protrusion shall not exceed 0.15 per side.
  - This package is designed to be soldered to a thermal pad on the board. Refer to Technical Brief, PowerPad Thermally Enhanced Package, Texas Instruments Literature No. SLMA002 for information regarding recommended board layout. This document is available at [www.ti.com](http://www.ti.com) <<http://www.ti.com>>.
  - See the additional figure in the Product Data Sheet for details regarding the exposed thermal pad features and dimensions.
  - Falls within JEDEC MO-153

PowerPAD is a trademark of Texas Instruments.

# THERMAL PAD MECHANICAL DATA

## PWP (R-PDSO-G20) PowerPAD™ SMALL PLASTIC OUTLINE

### THERMAL INFORMATION

This PowerPAD™ package incorporates an exposed thermal pad that is designed to be attached to a printed circuit board (PCB). The thermal pad must be soldered directly to the PCB. After soldering, the PCB can be used as a heatsink. In addition, through the use of thermal vias, the thermal pad can be attached directly to the appropriate copper plane shown in the electrical schematic for the device, or alternatively, can be attached to a special heatsink structure designed into the PCB. This design optimizes the heat transfer from the integrated circuit (IC).

For additional information on the PowerPAD package and how to take advantage of its heat dissipating abilities, refer to Technical Brief, PowerPAD Thermally Enhanced Package, Texas Instruments Literature No. SLMA002 and Application Brief, PowerPAD Made Easy, Texas Instruments Literature No. SLMA004. Both documents are available at [www.ti.com](http://www.ti.com).

The exposed thermal pad dimensions for this package are shown in the following illustration.

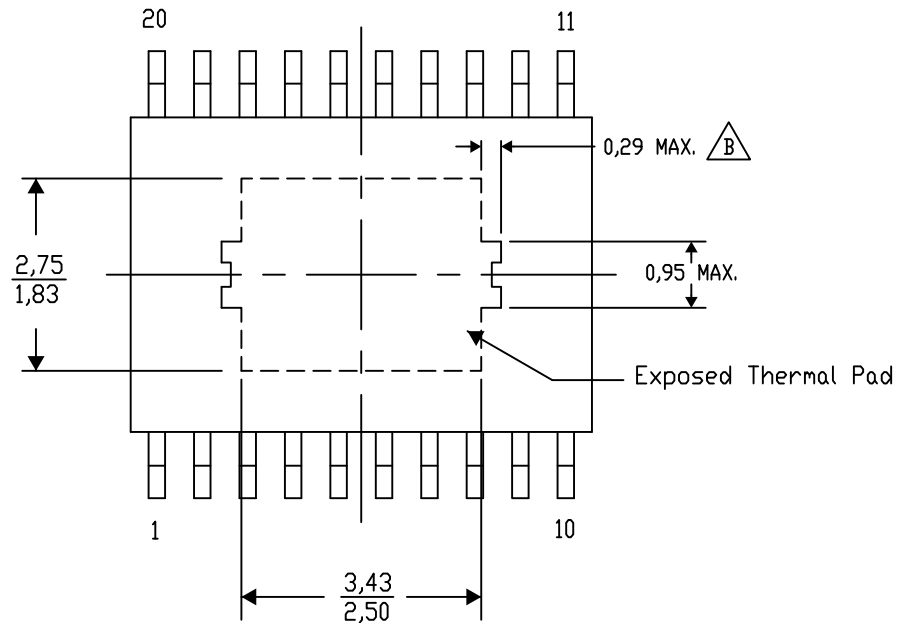

Top View

Exposed Thermal Pad Dimensions

4206332-17/AO 01/16

NOTE: A. All linear dimensions are in millimeters

 B. Exposed tie strap features may not be present.

PowerPAD is a trademark of Texas Instruments

PWP (R-PDSO-G20)

PowerPAD™ PLASTIC SMALL OUTLINE

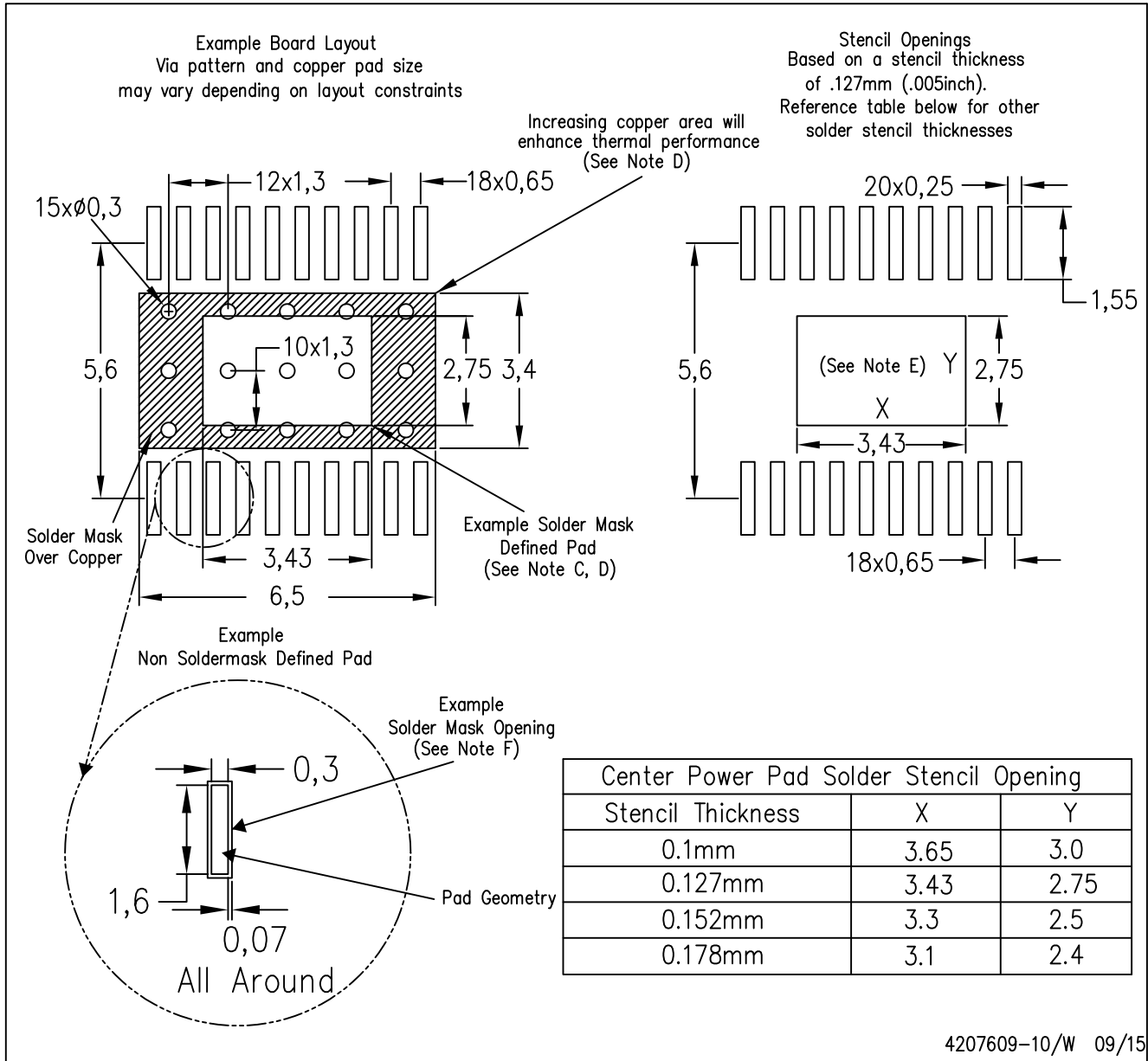

- NOTES:
- A. All linear dimensions are in millimeters.
  - B. This drawing is subject to change without notice.
  - C. Customers should place a note on the circuit board fabrication drawing not to alter the center solder mask defined pad.
  - D. This package is designed to be soldered to a thermal pad on the board. Refer to Technical Brief, PowerPad Thermally Enhanced Package, Texas Instruments Literature No. SLMA002, SLMA004, and also the Product Data Sheets for specific thermal information, via requirements, and recommended board layout. These documents are available at [www.ti.com](http://www.ti.com) <<http://www.ti.com>>. Publication IPC-7351 is recommended for alternate designs.
  - E. Laser cutting apertures with trapezoidal walls and also rounding corners will offer better paste release. Customers should contact their board assembly site for stencil design recommendations. Example stencil design based on a 50% volumetric metal load solder paste. Refer to IPC-7525 for other stencil recommendations.
  - F. Customers should contact their board fabrication site for solder mask tolerances between and around signal pads.

# THERMAL PAD MECHANICAL DATA

## PWP (R-PDSO-G20) PowerPAD™ SMALL PLASTIC OUTLINE

### THERMAL INFORMATION

This PowerPAD™ package incorporates an exposed thermal pad that is designed to be attached to a printed circuit board (PCB). The thermal pad must be soldered directly to the PCB. After soldering, the PCB can be used as a heatsink. In addition, through the use of thermal vias, the thermal pad can be attached directly to the appropriate copper plane shown in the electrical schematic for the device, or alternatively, can be attached to a special heatsink structure designed into the PCB. This design optimizes the heat transfer from the integrated circuit (IC).

For additional information on the PowerPAD package and how to take advantage of its heat dissipating abilities, refer to Technical Brief, PowerPAD Thermally Enhanced Package, Texas Instruments Literature No. SLMA002 and Application Brief, PowerPAD Made Easy, Texas Instruments Literature No. SLMA004. Both documents are available at [www.ti.com](http://www.ti.com).

The exposed thermal pad dimensions for this package are shown in the following illustration.

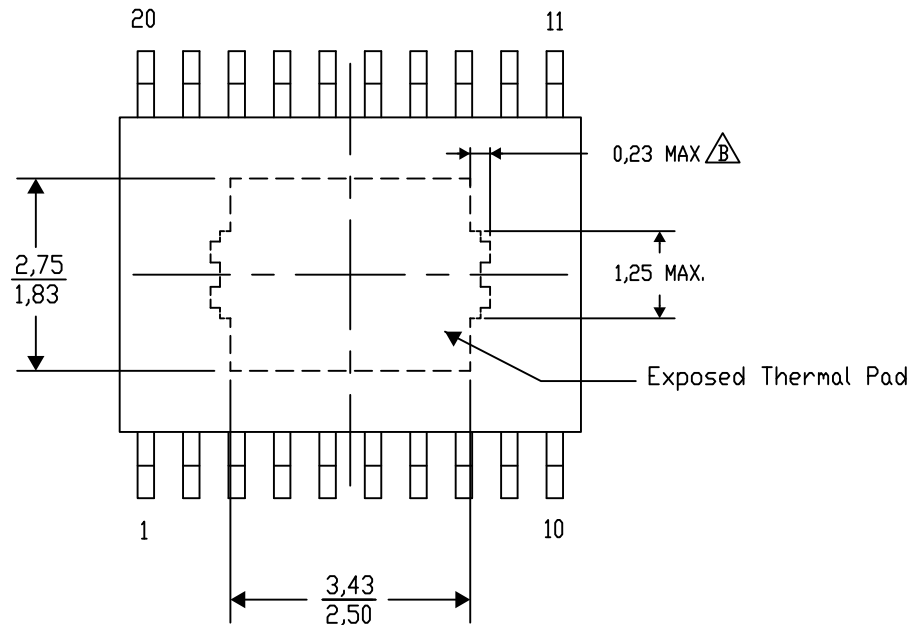

4206332-41/AO 01/16

NOTE: A. All linear dimensions are in millimeters

 Exposed tie strap features may not be present.

PowerPAD is a trademark of Texas Instruments

## 重要声明

德州仪器(TI) 及其下属子公司有权根据 JESD46 最新标准, 对所提供的产品和服务进行更正、修改、增强、改进或其它更改, 并有权根据 JESD48 最新标准中止提供任何产品和服务。客户在下订单前应获取最新的相关信息, 并验证这些信息是否完整且是最新的。所有产品的销售都遵循在订单确认时所提供的TI 销售条款与条件。

TI 保证其所销售的组件的性能符合产品销售时 TI 半导体产品销售条件与条款的适用规范。仅在 TI 保证的范围内, 且 TI 认为有必要时才会使用测试或其它质量控制技术。除非适用法律做出了硬性规定, 否则没有必要对每种组件的所有参数进行测试。

TI 对应用帮助或客户产品设计不承担任何义务。客户应对其使用 TI 组件的产品和应用自行负责。为尽量减小与客户产品和应用相关的风险, 客户应提供充分的设计与操作安全措施。

TI 不对任何 TI 专利权、版权、屏蔽作品权或其它与使用了 TI 组件或服务的组合设备、机器或流程相关的 TI 知识产权中授予的直接或间接版权限作出任何保证或解释。TI 所发布的与第三方产品或服务有关的信息, 不能构成从 TI 获得使用这些产品或服务的许可、授权、或认可。使用此类信息可能需要获得第三方的专利权或其它知识产权方面的许可, 或是 TI 的专利权或其它知识产权方面的许可。

对于 TI 的产品手册或数据表中 TI 信息的重要部分, 仅在没有对内容进行任何篡改且带有相关授权、条件、限制和声明的情况下才允许进行复制。TI 对此类篡改过的文件不承担任何责任或义务。复制第三方的信息可能需要服从额外的限制条件。

在转售 TI 组件或服务时, 如果对该组件或服务参数的陈述与 TI 标明的参数相比存在差异或虚假成分, 则会失去相关 TI 组件或服务的所有明示或暗示授权, 且这是不正当的、欺诈性商业行为。TI 对任何此类虚假陈述均不承担任何责任或义务。

客户认可并同意, 尽管任何应用相关信息或支持仍可能由 TI 提供, 但他们将独自负责满足与其产品及其应用中使用 TI 产品相关的所有法律、法规和安全相关要求。客户声明并同意, 他们具备制定与实施安全措施所需的全部专业技术和知识, 可预见故障的危险后果、监测故障及其后果、降低有可能造成人身伤害的故障的发生机率并采取适当的补救措施。客户将全额赔偿因在此类安全关键应用中使用任何 TI 组件而对 TI 及其代理造成的任何损失。

在某些场合中, 为了推进安全相关应用有可能对 TI 组件进行特别的促销。TI 的目标是利用此类组件帮助客户设计和创立其特有的可满足适用的功能安全性标准和要求的终端产品解决方案。尽管如此, 此类组件仍然服从这些条款。

TI 组件未获得用于 FDA Class III (或类似的生命攸关医疗设备) 的授权许可, 除非各方授权官员已经达成了专门管控此类使用的特别协议。

只有那些 TI 特别注明属于军用等级或“增强型塑料”的 TI 组件才是设计或专门用于军事/航空应用或环境的。购买者认可并同意, 对并非指定面向军事或航空航天用途的 TI 组件进行军事或航空航天方面的应用, 其风险由客户单独承担, 并且由客户独自负责满足与此类使用相关的所有法律和法规要求。

TI 已明确指定符合 ISO/TS16949 要求的产品, 这些产品主要用于汽车。在任何情况下, 因使用非指定产品而无法达到 ISO/TS16949 要求, TI 不承担任何责任。

	产品		应用
数字音频	<a href="http://www.ti.com.cn/audio">www.ti.com.cn/audio</a>	通信与电信	<a href="http://www.ti.com.cn/telecom">www.ti.com.cn/telecom</a>
放大器和线性器件	<a href="http://www.ti.com.cn/amplifiers">www.ti.com.cn/amplifiers</a>	计算机及周边	<a href="http://www.ti.com.cn/computer">www.ti.com.cn/computer</a>
数据转换器	<a href="http://www.ti.com.cn/dataconverters">www.ti.com.cn/dataconverters</a>	消费电子	<a href="http://www.ti.com.cn/consumer-apps">www.ti.com.cn/consumer-apps</a>
DLP® 产品	<a href="http://www.dlp.com">www.dlp.com</a>	能源	<a href="http://www.ti.com.cn/energy">www.ti.com.cn/energy</a>
DSP - 数字信号处理器	<a href="http://www.ti.com.cn/dsp">www.ti.com.cn/dsp</a>	工业应用	<a href="http://www.ti.com.cn/industrial">www.ti.com.cn/industrial</a>
时钟和计时器	<a href="http://www.ti.com.cn/clockandtimers">www.ti.com.cn/clockandtimers</a>	医疗电子	<a href="http://www.ti.com.cn/medical">www.ti.com.cn/medical</a>
接口	<a href="http://www.ti.com.cn/interface">www.ti.com.cn/interface</a>	安防应用	<a href="http://www.ti.com.cn/security">www.ti.com.cn/security</a>
逻辑	<a href="http://www.ti.com.cn/logic">www.ti.com.cn/logic</a>	汽车电子	<a href="http://www.ti.com.cn/automotive">www.ti.com.cn/automotive</a>
电源管理	<a href="http://www.ti.com.cn/power">www.ti.com.cn/power</a>	视频和影像	<a href="http://www.ti.com.cn/video">www.ti.com.cn/video</a>
微控制器 (MCU)	<a href="http://www.ti.com.cn/microcontrollers">www.ti.com.cn/microcontrollers</a>		
RFID 系统	<a href="http://www.ti.com.cn/rfidsys">www.ti.com.cn/rfidsys</a>		
OMAP应用处理器	<a href="http://www.ti.com.cn/omap">www.ti.com.cn/omap</a>		
无线连通性	<a href="http://www.ti.com.cn/wirelessconnectivity">www.ti.com.cn/wirelessconnectivity</a>	德州仪器在线技术支持社区	<a href="http://www.deyisupport.com">www.deyisupport.com</a>

Mailing Address: Texas Instruments, Post Office Box 655303, Dallas, Texas 75265  
Copyright © 2016, Texas Instruments Incorporated