

XTR305 工业模拟电流或电压输出驱动器

1 特性

- 用户可选：电流或电压输出
- V_{OUT} : $\pm 10V$ (电源电压为 $\pm 20V$ 时高达 $\pm 17.5V$)
- I_{OUT} : $\pm 20mA$ (线性电流高达 $\pm 24mA$)
- 40V 电源电压
- 诊断 特性:
 - 短路或开路故障指示灯引脚
 - 热保护
 - 过流保护
- 无需电流分流
- 适用于单输入模式的输出禁用
- 独立驱动器和接收器通道
- 专为可测试性而设计

2 应用

- 电机驱动器模式输出：电流为 4-20mA，电压为 $\pm 10V$
 - PLC 输出可编程驱动器
 - 工业交叉连接器
 - 工业高电压 I/O
 - 3 线传感器电流或电压输出
 - $\pm 10V$ 2 线和 4 线电压输出
- 美国专利号 7,427,898、7,425,848 和 7,449,873

3 说明

XTR305 是一个完整的输出驱动器，适用于成本敏感型工业和过程控制 应用供电的绝佳器件。数字 I/V 选择引脚可将输出配置为电流或电压。无需外部分流电阻器。只需要外部增益设置电阻器和环路补偿电容器。

独立的驱动器和接收器通道可提供灵活性。仪表放大器 (IA) 可用于远程电压传感或用作高电压、高阻抗测量通道。在电压输出模式下，提供输出电流的副本，允许计算负载电阻。

利用数字输出选择功能、错误标志以及监控器引脚，可进行远程配置和故障排除。输出和 IA 输入的故障条件以及过热情况由错误标志指示。监控引脚提供有关负载功率或阻抗的持续反馈。为了获得额外的保护，最大输出电流是受限的，并提供过热保护。

XTR305 具有 $-40^{\circ}C$ 至 $+85^{\circ}C$ 的额定工业温度范围，电源电压最高可达 40V，并可在 $-55^{\circ}C$ 至 $+125^{\circ}C$ 的扩展温度范围内正常运行。

器件信息⁽¹⁾

| 器件型号 | 封装 | 封装尺寸 (标称值) |
|--------|-----------|-----------------|
| XTR305 | VQFN (20) | 5.00mm x 5.00mm |

(1) 要了解所有可用封装，请见数据表末尾的可订购产品附录。

典型应用

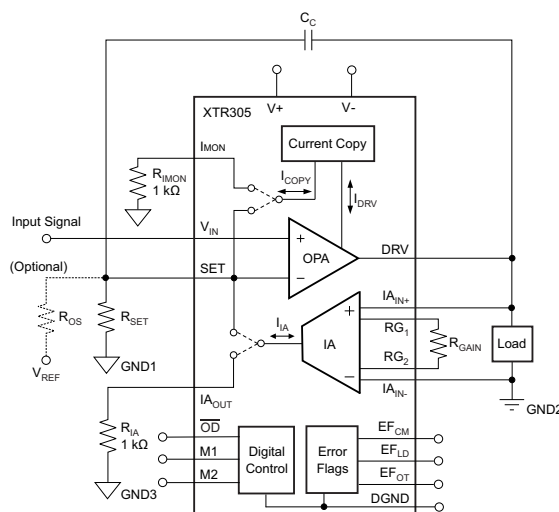

Copyright © 2017, Texas Instruments Incorporated



目录

| | | | | | |
|----------|--|-----------|-----------|---|-----------|
| 1 | 特性 | 1 | 7.2 | Functional Block Diagrams | 16 |
| 2 | 应用 | 1 | 7.3 | Feature Description | 18 |
| 3 | 说明 | 1 | 7.4 | Device Functional Modes | 20 |
| 4 | 修订历史记录 | 2 | 8 | Application and Implementation | 21 |
| 5 | Pin Configuration and Functions | 3 | 8.1 | Application Information | 21 |
| 6 | Specifications | 4 | 8.2 | Typical Application | 21 |
| 6.1 | Absolute Maximum Ratings | 4 | 9 | Power Supply Recommendations | 29 |
| 6.2 | ESD Ratings | 4 | 10 | Layout | 30 |
| 6.3 | Recommended Operating Conditions | 4 | 10.1 | Layout Guidelines | 30 |
| 6.4 | Thermal Information | 4 | 10.2 | Layout Example | 30 |
| 6.5 | Electrical Characteristics: Voltage Output Mode | 5 | 10.3 | VQFN Package and Heat Sinking | 31 |
| 6.6 | Electrical Characteristics: Current Output Mode | 6 | 10.4 | Power Dissipation | 32 |
| 6.7 | Electrical Characteristics: Operational Amplifier (OPA) | 7 | 11 | 器件和文档支持 | 33 |
| 6.8 | Electrical Characteristics: Instrumentation Amplifier (IA) | 8 | 11.1 | 文档支持 | 33 |
| 6.9 | Electrical Characteristics: Current Monitor | 9 | 11.2 | 接收文档更新通知 | 33 |
| 6.10 | Electrical Characteristics: Power and Digital | 9 | 11.3 | 社区资源 | 33 |
| 6.11 | Typical Characteristics | 10 | 11.4 | 商标 | 33 |
| 7 | Detailed Description | 16 | 11.5 | 静电放电警告 | 33 |
| 7.1 | Overview | 16 | 11.6 | Glossary | 33 |
| | | | 12 | 机械、封装和可订购信息 | 33 |

4 修订历史记录

注：之前版本的页码可能与当前版本有所不同。

| 日期 | 修订版本 | 说明 |
|------------|------|-------|
| 2018 年 2 月 | * | 初始发行版 |

5 Pin Configuration and Functions

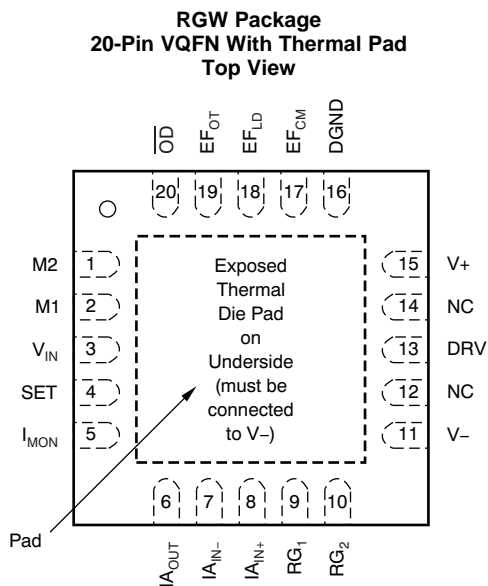

Pin Functions

| PIN | | I/O | DESCRIPTION |
|-----|------------------------|-----|---|
| NO. | NAME | | |
| 1 | M2 | I | Mode input |
| 2 | M1 | I | Mode input |
| 3 | V _{IN} | I | Noninverting signal input |
| 4 | SET | I | Input for gain setting; inverting input |
| 5 | I _{MON} | O | Current monitor output |
| 6 | I _{AOUT} | O | Instrumentation amplifier signal output |
| 7 | I _{A IN-} | I | Instrumentation amplifier inverting input |
| 8 | I _{A IN+} | I | Instrumentation amplifier noninverting input |
| 9 | RG1 | I | Instrumentation amplifier gain resistor |
| 10 | RG2 | I | Instrumentation amplifier gain resistor |
| 11 | V- | - | Negative power supply |
| 12 | NC | - | No internal connection |
| 13 | DRV | O | Operational amplifier output |
| 14 | NC | - | No internal connection |
| 15 | V+ | - | Positive power supply |
| 16 | DGND | - | Ground for digital I/O |
| 17 | E _{FCM} | O | Error flag for common mode over range, active low |
| 18 | E _{FLD} | O | Error flag for load error, active low |
| 19 | E _{FOT} | O | Error flag for over temperature, active low |
| 20 | $\overline{\text{OD}}$ | I | Output disable, disabled low |
| Pad | Exposed Pad | - | Exposed thermal pad must be connected to V- |

6 Specifications

6.1 Absolute Maximum Ratings

 over operating free-air temperature range (unless otherwise noted)⁽¹⁾

| | | MIN | MAX | UNIT |
|-------------------------------------|------------------------|------------|------------|------|
| Supply voltage, V_{VSP} | | | +44 | V |
| Signal input terminals | Voltage ⁽²⁾ | (V-) - 0.5 | (V+) + 0.5 | V |
| | Current ⁽²⁾ | | ±25 | mA |
| DGND | | | ±25 | mA |
| Output short circuit ⁽³⁾ | | Continuous | | |
| Operating temperature | | -55 | 125 | °C |
| Junction temperature | | | 150 | °C |
| Storage temperature, T_{stg} | | -55 | 125 | °C |

- (1) Stresses beyond those listed under *Absolute Maximum Ratings* may cause permanent damage to the device. These are stress ratings only, which do not imply functional operation of the device at these or any other conditions beyond those indicated under *Recommended Operating Conditions*. Exposure to absolute-maximum-rated conditions for extended periods may affect device reliability.
- (2) Input terminals are diode-clamped to the power-supply rails. Input signals that can swing more than 0.5 V beyond the supply rails must be current limited. DRV pin allows a peak current of 50 mA. See the *Output Protection* section in *Application and Implementation*.
- (3) See *Driver Output Disable* in *Application and Implementation* for thermal protection.

6.2 ESD Ratings

| | | VALUE | UNIT |
|-------------------------------------|--|-------|------|
| $V_{(ESD)}$ Electrostatic discharge | Human-body model (HBM), per ANSI/ESDA/JEDEC JS-001 ⁽¹⁾ | ±2000 | V |
| | Charged-device model (CDM), per JEDEC specification JESD22-C101 ⁽²⁾ | ±1000 | |

- (1) JEDEC document JEP155 states that 500-V HBM allows safe manufacturing with a standard ESD control process.
- (2) JEDEC document JEP157 states that 250-V CDM allows safe manufacturing with a standard ESD control process.

6.3 Recommended Operating Conditions

over operating free-air temperature range (unless otherwise noted)

| | MIN | NOM | MAX | UNIT |
|-----------------------------|-----|-----|--------------------|------|
| Specified temperature range | -40 | | 85 | °C |
| Operating temperature range | -55 | | 125 ⁽¹⁾ | °C |

- (1) EF_{OT} not connected with \overline{OD} .

6.4 Thermal Information

| THERMAL METRIC ⁽¹⁾ | | XTR305 | UNIT |
|-------------------------------|--|------------|------|
| | | RGW (VQFN) | |
| | | 20 PINS | |
| $R_{\theta JA}$ | Junction-to-ambient thermal resistance | 32.9 | °C/W |
| $R_{\theta JC(top)}$ | Junction-to-case (top) thermal resistance | 25.1 | °C/W |
| $R_{\theta JB}$ | Junction-to-board thermal resistance | 12.6 | °C/W |
| Ψ_{JT} | Junction-to-top characterization parameter | 0.3 | °C/W |
| Ψ_{JB} | Junction-to-board characterization parameter | 12.6 | °C/W |
| $R_{\theta JC(bot)}$ | Junction-to-case (bottom) thermal resistance | 3.1 | °C/W |

- (1) For more information about traditional and new thermal metrics, see the *Semiconductor and IC Package Thermal Metrics* application report.

6.5 Electrical Characteristics: Voltage Output Mode

All specifications at $T_A = 25^\circ\text{C}$, $V_S = \pm 20\text{ V}$, $R_{\text{LOAD}} = 800\ \Omega$, $R_{\text{SET}} = 2\ \text{k}\Omega$, $R_{\text{OS}} = 2\ \text{k}\Omega$, $V_{\text{REF}} = 4\ \text{V}$, $R_{\text{GAIN}} = 10\ \text{k}\Omega$, input signal span 0 V to 4 V, and $C_C = 100\ \text{pF}$, unless otherwise noted.

| PARAMETER | | TEST CONDITIONS | MIN | TYP | MAX | UNIT |
|----------------------------|--|---|------------|------------|------------|------------------------------|
| OFFSET VOLTAGE | | | | | | |
| V_{OS} | Offset voltage, RTI | | | ± 0.4 | ± 2.5 | mV |
| dV_{OS}/dT | Offset voltage vs temperature | $T_A = -40^\circ\text{C}$ to 85°C | | ± 1.6 | ± 10 | $\mu\text{V}/^\circ\text{C}$ |
| PSRR | Offset voltage vs power supply | $V_S = \pm 5\ \text{V}$ to $\pm 22\ \text{V}$ | | ± 0.2 | ± 10 | $\mu\text{V}/\text{V}$ |
| INPUT VOLTAGE RANGE | | | | | | |
| | Nominal setup for $\pm 10\text{-V}$ output | See Figure 35 | | | | |
| | Input voltage for linear operation | | $(V-) + 3$ | | $(V+) - 3$ | V |
| NOISE | | | | | | |
| | Voltage noise, $f = 0.1\ \text{Hz}$ to $10\ \text{Hz}$, RTI | | | 3 | | μV_{PP} |
| e_n | Voltage noise density, $f = 1\ \text{kHz}$, RTI | | | 40 | | $\text{nV}/\sqrt{\text{Hz}}$ |
| OUTPUT | | | | | | |
| | Voltage output swing from rail | $I_{\text{DRV}} \leq 15\ \text{mA}$, $T_A = -40^\circ\text{C}$ to 85°C | $(V-) + 3$ | | $(V+) - 3$ | V |
| | Gain nonlinearity | | | ± 0.01 | ± 0.2 | %FS |
| | Gain nonlinearity vs temperature | $T_A = -40^\circ\text{C}$ to 85°C | | ± 0.1 | ± 1 | $\text{ppm}/^\circ\text{C}$ |
| I_B | Gain error | | | ± 0.04 | ± 0.2 | %FS |
| | Gain error vs temperature | $T_A = -40^\circ\text{C}$ to 85°C | | ± 0.2 | ± 1 | $\text{ppm}/^\circ\text{C}$ |
| | Output impedance, $dV_{\text{DRV}}/dI_{\text{DRV}}$ | | | 7 | | $\text{m}\Omega$ |
| | Output leakage current while output disabled | $\overline{\text{OD}}$ pin = L ⁽¹⁾ , $T_A = -40^\circ\text{C}$ to 85°C | | 30 | | nA |
| I_{SC} | Short-circuit current | $T_A = -40^\circ\text{C}$ to 85°C | ± 15 | ± 20 | ± 24 | mA |
| C_{LOAD} | Capacitive load drive | $C_C = 10\ \text{nF}$, $R_C = 15$ ⁽²⁾ | | 1 | | μF |
| | Rejection of voltage difference between GND1 and GND2, RTO | | | 130 | | dB |
| FREQUENCY RESPONSE | | | | | | |
| | Bandwidth ⁽³⁾ | $-3\ \text{dB}$, $G = 5$ | | 300 | | kHz |
| SR | Slew rate ⁽²⁾ | | | 1 | | $\text{V}/\mu\text{s}$ |
| | | $C_C = 10\ \text{nF}$, $C_{\text{LOAD}} = 1\ \mu\text{F}$, $R_C = 15\ \Omega$ | | 0.015 | | |
| | Settling time ⁽²⁾⁽⁴⁾ , 0.1%, small signal | $V_{\text{DRV}} = \pm 1\ \text{V}$ | | 8 | | μs |
| | Overload recovery time | 50% overdrive | | 12 | | μs |

(1) Output leakage includes input bias current of INA.

(2) Refer to [Driving Capacitive Loads and Loop Compensation](#) section in [Application and Implementation](#).

(3) Small signal with no capacitive load.

(4) 8 μs plus number of chopping periods. See [Application and Implementation, Internal Current Sources, Switching Noise, and Settling Time](#) section.

6.6 Electrical Characteristics: Current Output Mode

All specifications at $T_A = 25^\circ\text{C}$, $V_S = \pm 20\text{ V}$, $R_{\text{LOAD}} = 800\ \Omega$, $R_{\text{SET}} = 2\ \text{k}\Omega$, $R_{\text{OS}} = 2\ \text{k}\Omega$, $V_{\text{REF}} = 4\ \text{V}$, input signal span 0 V to 4 V, and $C_C = 100\ \text{pF}$, unless otherwise noted.

| PARAMETER | | TEST CONDITIONS | MIN | TYP | MAX | UNIT |
|----------------------------|--|--|------------|------------|------------|------------------------------|
| OFFSET VOLTAGE | | | | | | |
| V_{OS} | Input offset voltage | Output current < 1 μA | | ± 0.4 | ± 2.5 | mV |
| dV_{OS}/dT | Input offset voltage vs temperature | | | ± 1.5 | ± 10 | $\mu\text{V}/^\circ\text{C}$ |
| PSRR | Input offset voltage vs power supply | $V_S = \pm 5\ \text{V}$ to $\pm 22\ \text{V}$ | | ± 0.2 | ± 10 | $\mu\text{V}/\text{V}$ |
| INPUT VOLTAGE RANGE | | | | | | |
| | Nominal setup for $\pm 20\text{-mA}$ output | See Figure 36 | | | | |
| | Maximum input voltage for linear operation | | $(V-) + 3$ | | $(V+) - 3$ | V |
| NOISE | | | | | | |
| | Voltage noise, $f = 0.1\text{Hz}$ to 10Hz , RTI | | | 3 | | μV_{PP} |
| e_n | Voltage noise density, $f = 1\text{kHz}$, RTI | | | 33 | | $\text{nV}/\sqrt{\text{Hz}}$ |
| OUTPUT | | | | | | |
| | Compliance voltage swing from rail | $I_{\text{DRV}} = \pm 24\ \text{mA}$ | $(V-) + 3$ | | $(V+) - 3$ | V |
| | Output conductance ($dI_{\text{DRV}}/dV_{\text{DRV}}$) | $dV_{\text{DRV}} = \pm 15\ \text{V}$, $dI_{\text{DRV}} = \pm 24\ \text{mA}$ | | 0.7 | | $\mu\text{A}/\text{V}$ |
| | Transconductance | See transfer function in Figure 36 | | | | |
| | Gain error | $I_{\text{DRV}} = \pm 24\ \text{mA}$ | | ± 0.04 | ± 0.2 | %FS |
| | Gain error vs temperature | $I_{\text{DRV}} = \pm 24\ \text{mA}$ | | ± 3.6 | ± 10 | $\text{ppm}/^\circ\text{C}$ |
| I_B | Linearity error | $I_{\text{DRV}} = \pm 24\ \text{mA}$ | | ± 0.01 | ± 0.2 | %FS |
| | Linearity error vs temperature | $I_{\text{DRV}} = \pm 24\ \text{mA}$ | | ± 1.5 | ± 10 | $\text{ppm}/^\circ\text{C}$ |
| | Output leakage current while output disabled | $\overline{\text{OD}}$ pin = L | | 0.6 | | nA |
| I_{SC} | Short-circuit current | | ± 24.5 | ± 32 | ± 38.5 | mA |
| C_{LOAD} | Capacitive load drive ⁽¹⁾⁽²⁾ | | | 1 | | μF |
| FREQUENCY RESPONSE | | | | | | |
| | Bandwidth | -3 dB | | 160 | | kHz |
| SR | Slew rate ⁽²⁾ | | | 1.3 | | $\text{mA}/\mu\text{s}$ |
| | Settling time ⁽²⁾⁽³⁾ , 0.1%, Small Signal | $I_{\text{DRV}} = \pm 2\ \text{mA}$ | | 8 | | μs |
| | Overload recovery time | $C_{\text{LOAD}} = 0$, 50% overdrive | | 1 | | μs |

(1) Refer to [Driving Capacitive Loads and Loop Compensation](#) section in [Application and Implementation](#).

(2) With capacitive load, the slew rate can be limited by the short circuit current and the load error flag can trigger during slewing.

(3) 8 μs plus number of chopping periods. See [Application and Implementation](#), [Internal Current Sources](#), [Switching Noise](#), and [Settling Time](#) section.

6.7 Electrical Characteristics: Operational Amplifier (OPA)

All specifications at $T_A = 25^\circ\text{C}$, $V_S = \pm 20\text{ V}$, and $R_{LOAD} = 800\ \Omega$, unless otherwise noted.

| PARAMETER | | TEST CONDITIONS | MIN | TYP | MAX | UNIT |
|----------------------------|--|---|------------|--------------------|------------|------------------------------|
| OFFSET VOLTAGE | | | | | | |
| V_{OS} | Offset voltage, RTI | $I_{DRV} = 0\text{ A}$ | | ± 0.4 | ± 2.5 | mV |
| dV_{OS}/dT | Offset voltage drift | $T_A = -40^\circ\text{C}$ to 85°C | | ± 1.5 | | $\mu\text{V}/^\circ\text{C}$ |
| PSRR | Offset voltage vs power supply | $V_S = \pm 5\text{ V}$ to $\pm 22\text{ V}$ | | ± 0.2 | ± 10 | $\mu\text{V}/\text{V}$ |
| INPUT VOLTAGE RANGE | | | | | | |
| V_{CM} | Common-mode voltage range | | $(V-) + 3$ | | $(V+) - 3$ | V |
| CMRR | Common-mode rejection ratio | $(V-) + 3\text{ V} < V_{CM} < (V+) - 3\text{ V}$ | 95 | 126 | | dB |
| INPUT BIAS CURRENT | | | | | | |
| I_B | Input bias current | | | ± 20 | ± 35 | nA |
| I_{OS} | Input offset current | | | ± 0.3 | ± 10 | nA |
| INPUT IMPEDANCE | | | | | | |
| | Differential | | | $10^8 \parallel 5$ | | $\Omega \parallel \text{pF}$ |
| | Common-mode | | | $10^8 \parallel 5$ | | $\Omega \parallel \text{pF}$ |
| OPEN-LOOP GAIN | | | | | | |
| A_{OL} | Open-loop voltage gain | $(V-) + 3\text{ V} < V_{DRV} < (V+) - 3\text{ V}$, $I_{DRV} = \pm 24\text{ mA}$ | 95 | 126 | | dB |
| OUTPUT | | | | | | |
| | Voltage output swing from rail | $I_{DRV} = \pm 24\text{ mA}$ | $(V-) + 3$ | | $(V+) - 3$ | V |
| I_{LIMIT} | Short-circuit current | M2 = high | ± 25.5 | ± 32 | ± 38.5 | mA |
| I_{LIMIT} | | M2 = low | ± 16 | ± 20 | ± 24 | mA |
| I_{LEAK_DRV} | Output leakage current while output disabled | \overline{OD} pin = L | | 10 | | pA |
| FREQUENCY RESPONSE | | | | | | |
| GBW | Gain-bandwidth product | $G = 1$ | | 2 | | MHz |
| SR | Slew rate | | | 1 | | V/ μs |

6.8 Electrical Characteristics: Instrumentation Amplifier (IA)

All specifications at $T_A = 25^\circ\text{C}$, $V_S = \pm 20\text{ V}$, $R_{IA} = 2\text{ k}\Omega$, and $R_{GAIN} = 2\text{ k}\Omega$, unless otherwise noted. See [Figure 37](#).

| PARAMETER | TEST CONDITIONS | MIN | TYP | MAX | UNIT | |
|--|---|---|-----|--------------------|------------|------------------------------|
| OFFSET VOLTAGE | | | | | | |
| V_{OS} | Offset voltage, RTI | $I_{DRV} = 0\text{ A}$ | | ± 0.7 | ± 2.7 | mV |
| dV_{OS}/dT | Offset voltage vs temperature | $T_A = -40^\circ\text{C}$ to 85°C | | ± 2.4 | ± 10 | $\mu\text{V}/^\circ\text{C}$ |
| PSRR | Offset voltage vs power supply | $V_S = \pm 5\text{ V}$ to $\pm 22\text{ V}$ | | ± 0.8 | ± 10 | $\mu\text{V}/\text{V}$ |
| INPUT VOLTAGE RANGE | | | | | | |
| V_{CM} | Input voltage range | | | $(V-) + 3$ | $(V+) - 3$ | V |
| CMRR | Common-mode rejection ratio | RTI | | 100 | 130 | dB |
| INPUT BIAS CURRENT | | | | | | |
| I_B | Input bias current | | | ± 20 | ± 35 | nA |
| I_{OS} | Input offset current | | | ± 1 | ± 10 | nA |
| INPUT IMPEDANCE | | | | | | |
| | Differential | | | $10^5 \parallel 5$ | | $\Omega \parallel \text{pF}$ |
| | Common-mode | | | $10^5 \parallel 5$ | | $\Omega \parallel \text{pF}$ |
| TRANSCONDUCTANCE (Gain)⁽¹⁾ | | | | | | |
| | Transconductance error | $I_{AOUT} = \pm 2.4\text{ mA}$, $(V-) + 3\text{ V} < V_{IAOUT} < (V+) - 3\text{ V}$ | | ± 0.04 | ± 0.1 | %FS |
| | Transconductance error vs temperature | $T_A = -40^\circ\text{C}$ to 85°C | | ± 0.2 | | ppm/ $^\circ\text{C}$ |
| | Linearity error | $(V-) + 3\text{ V} < V_{IAOUT} < (V+) - 3\text{ V}$ | | ± 0.01 | ± 0.1 | %FS |
| | Input bias current to G1, G2 | | | ± 20 | | nA |
| | Input offset current to G1, G2 ⁽²⁾ | | | ± 1 | | nA |
| OUTPUT | | | | | | |
| | Output swing to the rail | $I_{AOUT} = \pm 2.4\text{ mA}$ | | $(V-) + 3$ | $(V+) - 3$ | V |
| | Output impedance | $I_{AOUT} = \pm 2.4\text{ mA}$ | | 600 | | $\text{m}\Omega$ |
| I_{LIMIT} | Short-circuit current | M2 = High | | ± 7.2 | | mA |
| | | M2 = Low | | ± 4.5 | | mA |
| FREQUENCY RESPONSE | | | | | | |
| GBW | Gain-bandwidth product | $G = 1$, $R_{GAIN} = 10\text{ k}\Omega$, $R_{IA} = 5\text{ k}\Omega$ | | 1 | | MHz |
| SR | Slew rate | $G = 1$, $R_{GAIN} = 10\text{ k}\Omega$, $R_{IA} = 5\text{ k}\Omega$ | | 1 | | $\text{V}/\mu\text{s}$ |
| | Settling time ⁽³⁾ , 0.1% | $I_{AOUT} = \pm 40\text{ }\mu\text{A}$, $R_{GAIN} = 10\text{ k}\Omega$, $R_{IA} = 5\text{ k}\Omega$, $C_L = 100\text{ pF}$ | | 6 | | μs |
| | Overload recovery time, 50% | $R_{GAIN} = 10\text{ k}\Omega$, $R_{IA} = 15\text{ k}\Omega$, $C_L = 100\text{ pF}$ | | 10 | | μs |

(1) Use equation: $I_{AOUT} = 2(I_{IN+} - I_{IN-}) / R_{GAIN}$

(2) See typical characteristics curve ([Figure 3](#)).

(3) 6 μs plus number of chopping periods. See [Application and Implementation, Internal Current Sources, Switching Noise, and Settling Time](#).

6.9 Electrical Characteristics: Current Monitor

All specifications at $T_A = 25^\circ\text{C}$ and $V_S = \pm 20\text{ V}$, unless otherwise noted. See [Figure 37](#).

| PARAMETER | | TEST CONDITIONS | MIN | TYP | MAX | UNIT |
|---|-----------------------------------|--|------------|------------|------------|-----------------------|
| OUTPUT | | | | | | |
| I_{OS} | Offset current | $I_{DRV} = 0\text{ A}$ | | ± 30 | ± 100 | nA |
| dI_{OS}/dT | Offset current drift | $T_A = -40^\circ\text{C}$ to 85°C | | ± 0.05 | | nA/ $^\circ\text{C}$ |
| PSRR | Offset current vs power supply | $V_S = \pm 5\text{ V}$ to $\pm 22\text{ V}$ | | ± 0.1 | ± 10 | nA/V |
| | Monitor output swing to the rail | $I_{MON} = \pm 2.4\text{ mA}$ | $(V-) + 3$ | | $(V+) - 3$ | V |
| | Monitor output impedance | $I_{MON} = \pm 2.4\text{ mA}$ | | 200 | | $M\Omega$ |
| MONITOR CURRENT GAIN⁽¹⁾ | | | | | | |
| | Current gain error | $I_{DRV} = \pm 24\text{ mA}$ | | ± 0.04 | ± 0.12 | %FS |
| | Current gain error vs temperature | $I_{DRV} = \pm 24\text{ mA}$, $T_A = -40^\circ\text{C}$ to 85°C | | ± 3.6 | | ppm/ $^\circ\text{C}$ |
| | Linearity error | $I_{DRV} = \pm 24\text{ mA}$ | | ± 0.01 | ± 0.1 | %FS |
| | Linearity error vs temperature | $I_{DRV} = \pm 24\text{ mA}$, $T_A = -40^\circ\text{C}$ to 85°C | | ± 1.5 | | ppm/ $^\circ\text{C}$ |

(1) Use equation: $I_{MON} = I_{DRV} / 10$

6.10 Electrical Characteristics: Power and Digital

All specifications at $T_A = 25^\circ\text{C}$ and $V_S = \pm 20\text{ V}$, unless otherwise noted. See [Figure 37](#).

| PARAMETER | | TEST CONDITIONS | MIN | TYP | MAX | UNIT |
|--|--|--|---------|------------|----------|------------------|
| POWER SUPPLY | | | | | | |
| V_S | Specified voltage range | | ± 5 | | ± 20 | V |
| | Operating voltage range | | ± 5 | | ± 22 | V |
| I_Q | Quiescent current | $I_{DRV} = I_{AOUT} = 0\text{ A}$ | | 1.8 | 2.3 | mA |
| | Quiescent current over temperature | $T_A = -40^\circ\text{C}$ to 85°C | | | 2.8 | mA |
| THERMAL FLAG (EF_{OT}) OUTPUT | | | | | | |
| | Alarm (EF _{OT} pin LOW) | | | 140 | | $^\circ\text{C}$ |
| | Return to normal operation (EF _{OT} pin HIGH) | | | 125 | | $^\circ\text{C}$ |
| DIGITAL INPUTS (M1, M2, \overline{OD}) | | | | | | |
| | V_{IL} low-level input voltage | | | ≤ 0.8 | | V |
| | V_{IH} high-level input voltage | | | > 1.4 | | V |
| | Input current | | | ± 1 | | μA |
| DIGITAL OUTPUTS (EF_{LD}, EF_{CM}, EF_{OT}) | | | | | | |
| | I_{OH} high-level leakage current (open-drain) | | | -1.2 | | μA |
| | V_{OL} low-level output voltage | $I_{OL} = 5\text{ mA}$ | | 0.8 | | V |
| | V_{OL} low-level output voltage | $I_{OL} = 2.8\text{ mA}$ | | 0.4 | | V |
| DIGITAL GROUND PIN⁽¹⁾ | | | | | | |
| | Current input | M1 = M2 = L, $\overline{OD} = H$, all digital outputs H | | -25 | | μA |

(1) Use equation: $(V-) \leq \text{DGND} \leq (V+) - 7\text{ V}$

6.11 Typical Characteristics

at $T_A = 25^\circ\text{C}$ and $V_+ = \pm 20\text{ V}$, unless otherwise noted

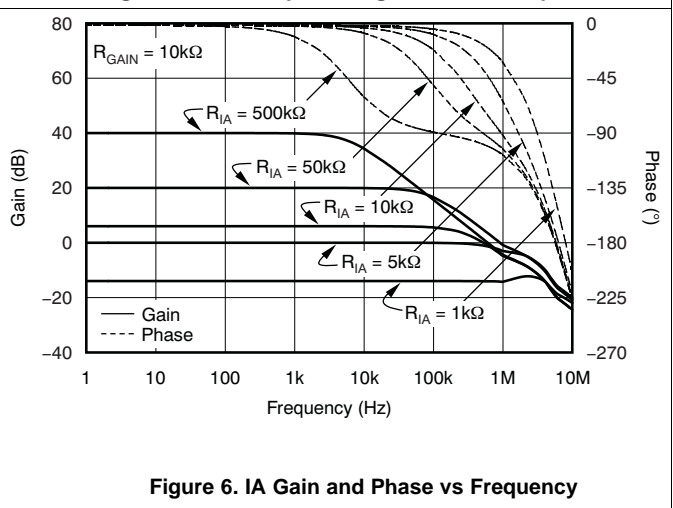
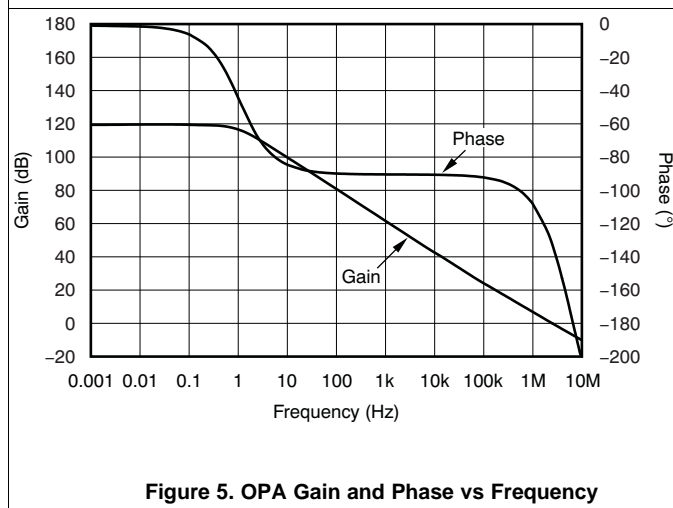
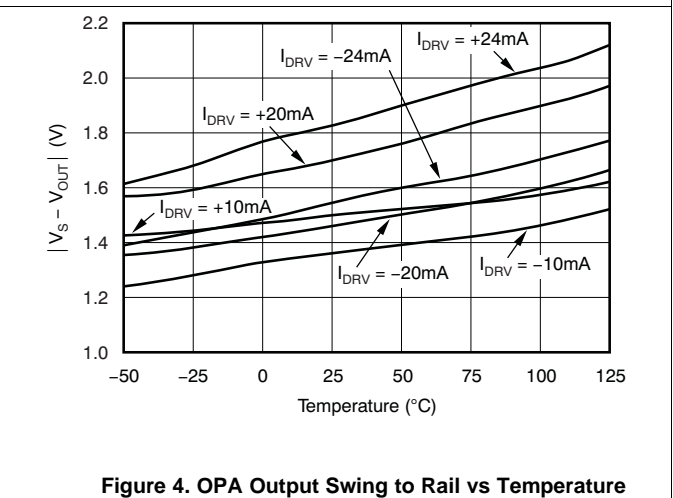
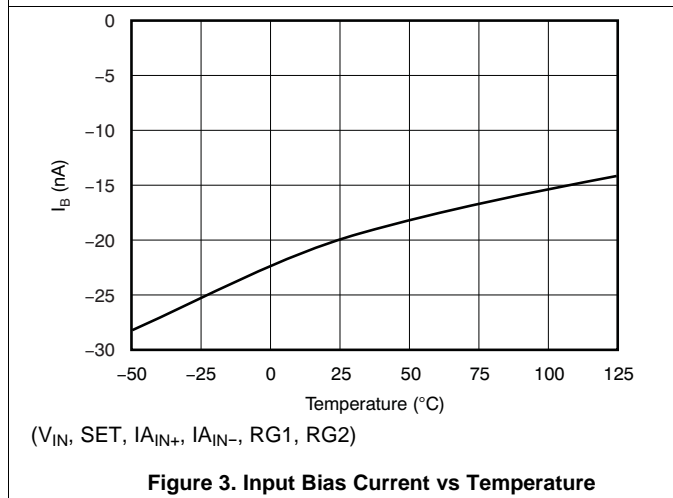
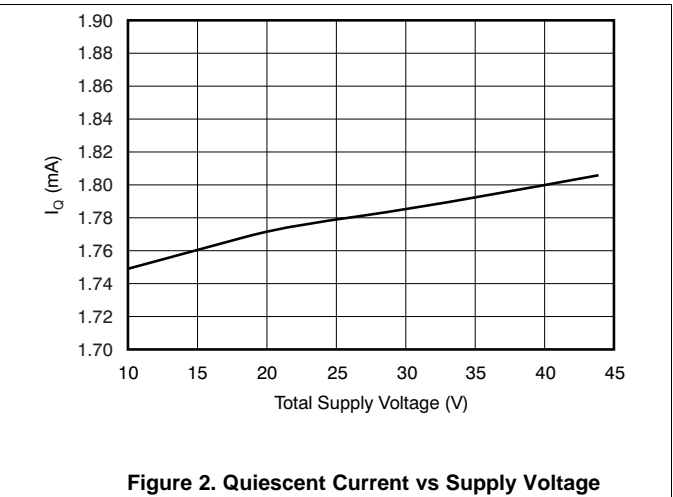
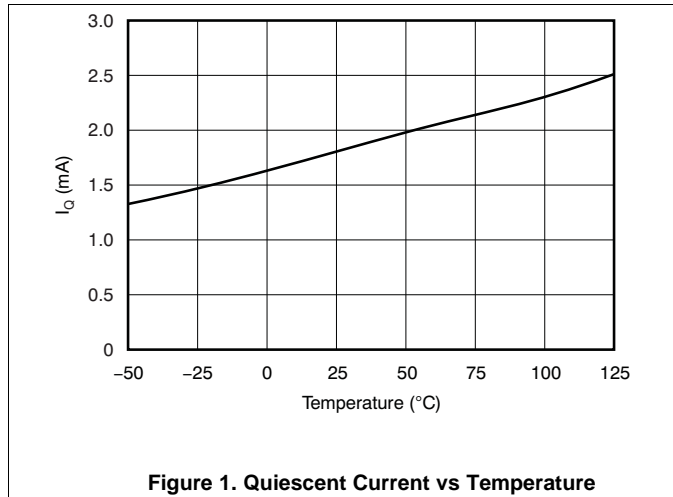

Typical Characteristics (continued)

at $T_A = 25^\circ\text{C}$ and $V_+ = \pm 20\text{ V}$, unless otherwise noted

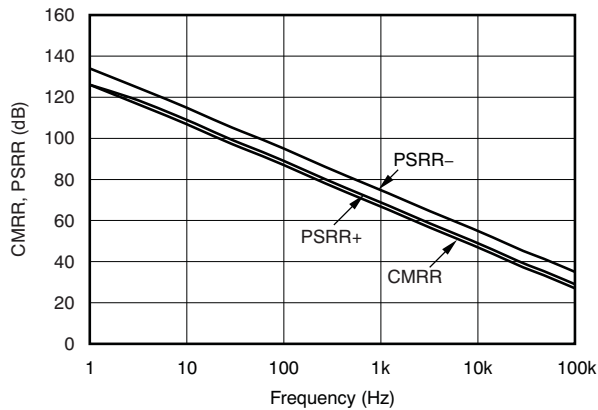

Figure 7. OPA CMRR and PSRR vs Frequency

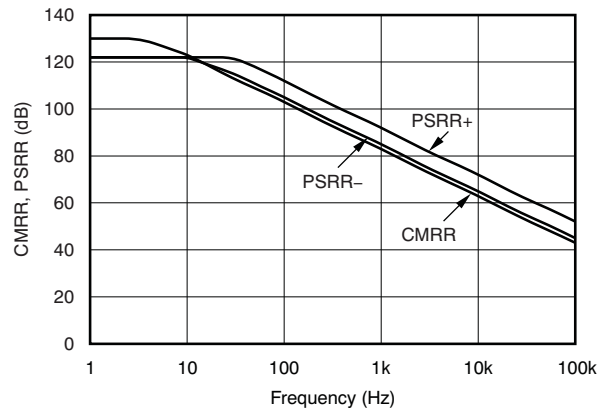

Figure 8. IA CMRR and PSRR vs Frequency

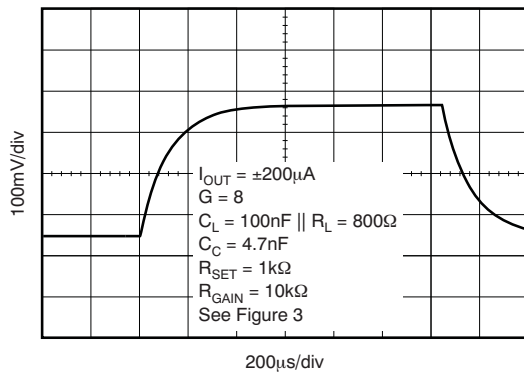

Figure 9. Small-Signal Step Response Current Mode

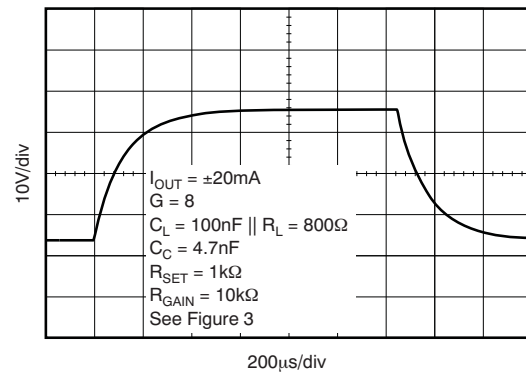

Figure 10. Large-Signal Step Response Current Mode

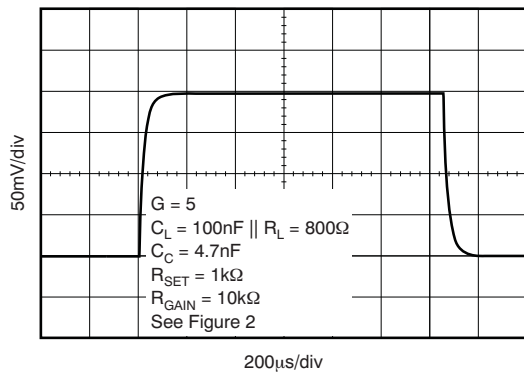

Figure 11. Small-Signal Step Response Voltage Mode

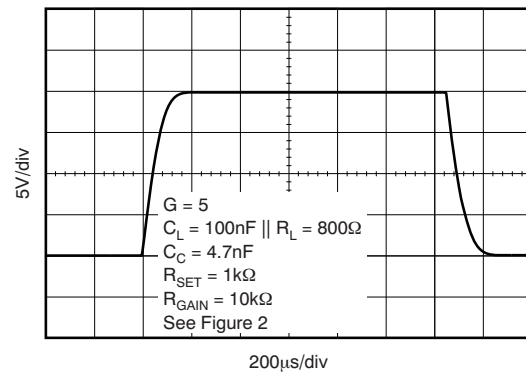
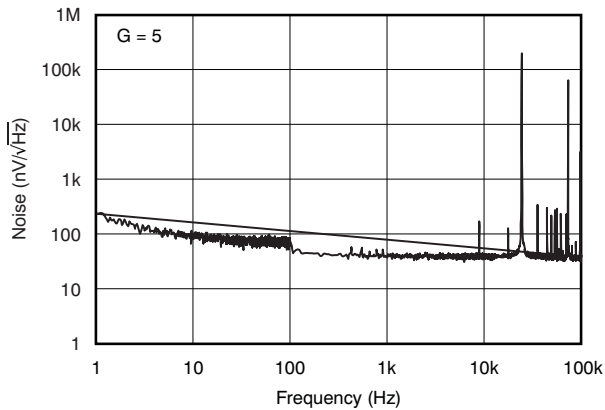

Figure 12. Large-Signal Step Response Voltage Mode

Typical Characteristics (continued)

at $T_A = 25^\circ\text{C}$ and $V_+ = \pm 20\text{ V}$, unless otherwise noted



**Figure 13. Input-Referred Noise Spectrum
Voltage Output Mode**

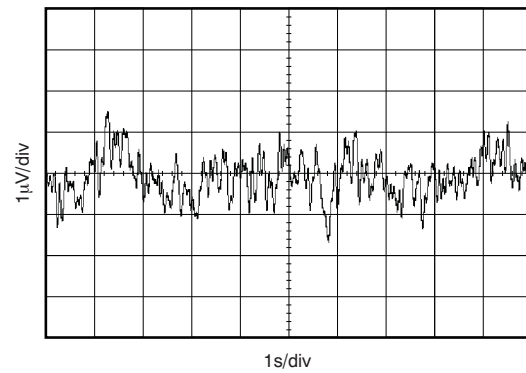

**Figure 14. Input-Referred 0.1-Hz to 10-Hz Noise
Voltage Output Mode**

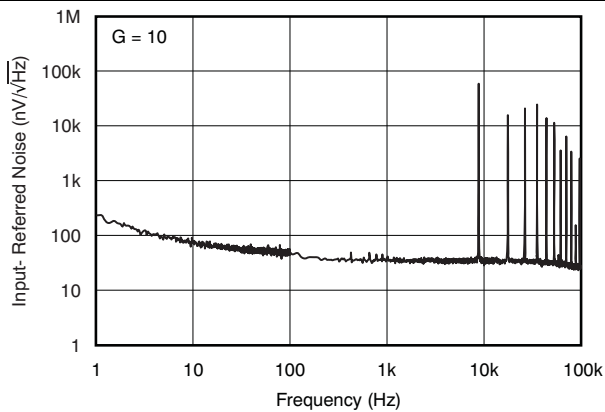

**Figure 15. Input-Referred Noise Spectrum
Current Output Mode**

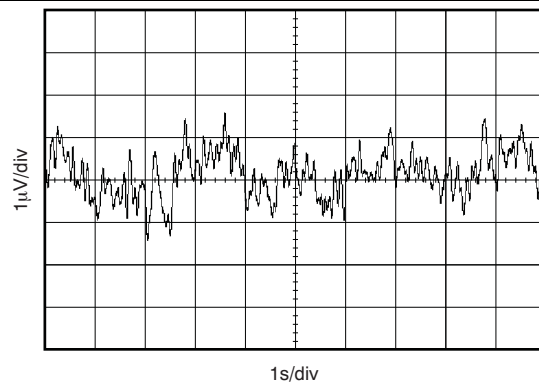

**Figure 16. Input-Referred 0.1-Hz to 10-Hz Noise
Current Output Mode**

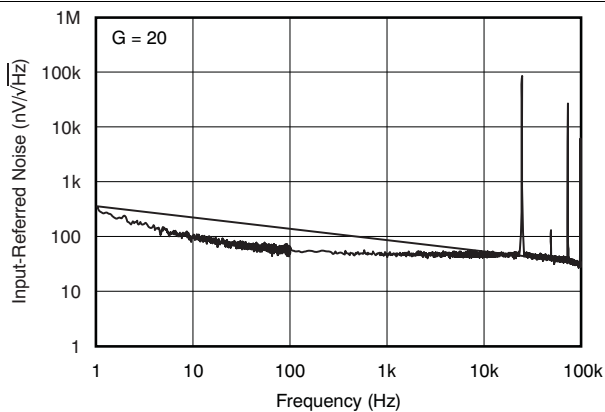

Figure 17. IA Input-Referred Noise Spectrum

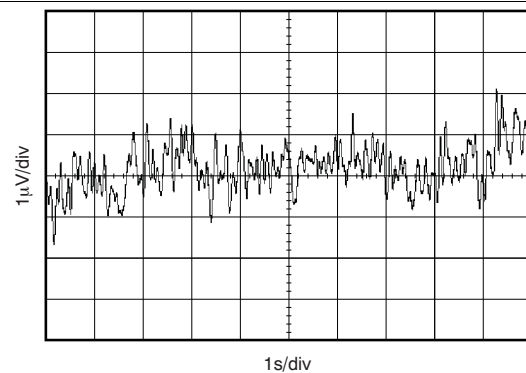

Figure 18. IA Input-Referred 0.1-Hz to 10-Hz Noise

Typical Characteristics (continued)

at $T_A = 25^\circ\text{C}$ and $V_+ = \pm 20\text{ V}$, unless otherwise noted

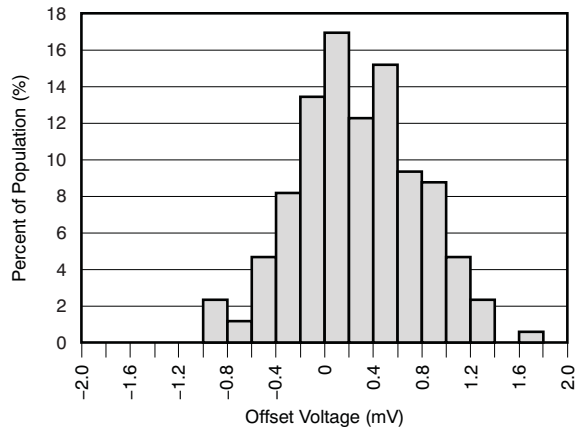

Figure 19. OPA Offset Voltage Distribution

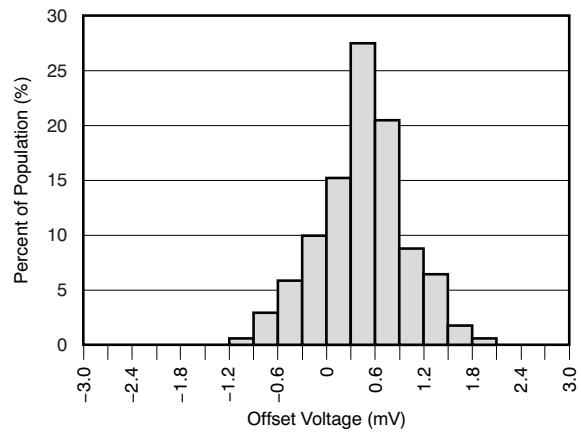

Figure 20. IA Offset Voltage Distribution

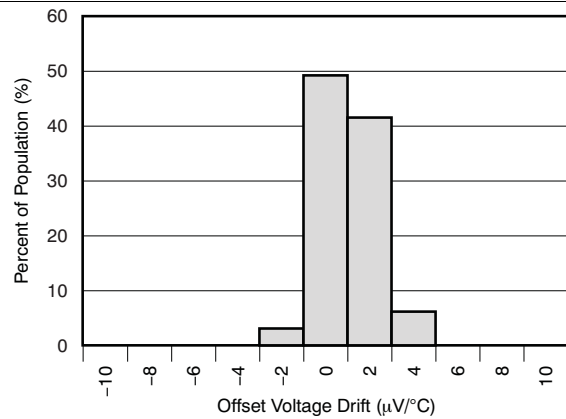

Figure 21. OPA Offset Voltage Drift Distribution

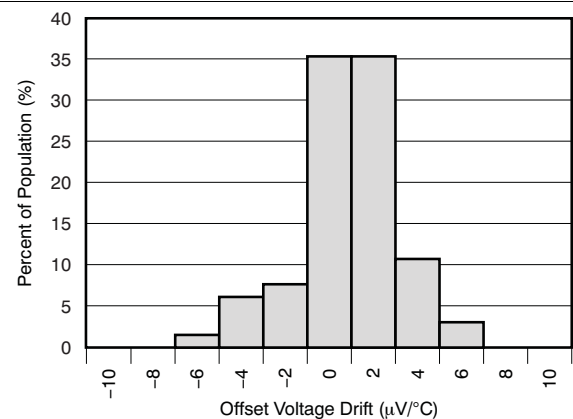

Figure 22. IA Offset Voltage Drift Distribution

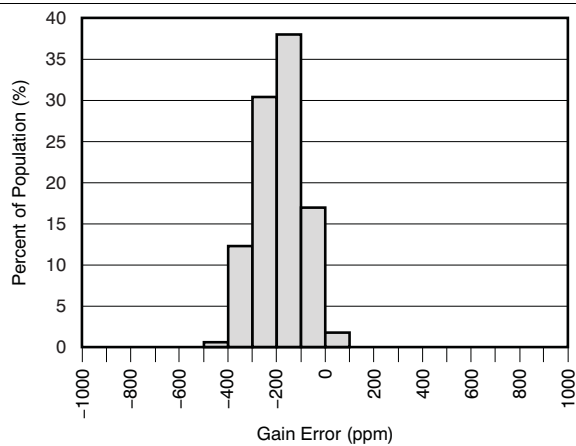

Figure 23. Voltage Mode Gain Error Distribution

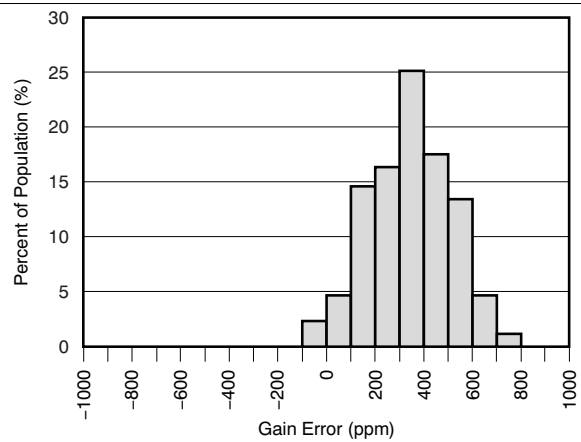
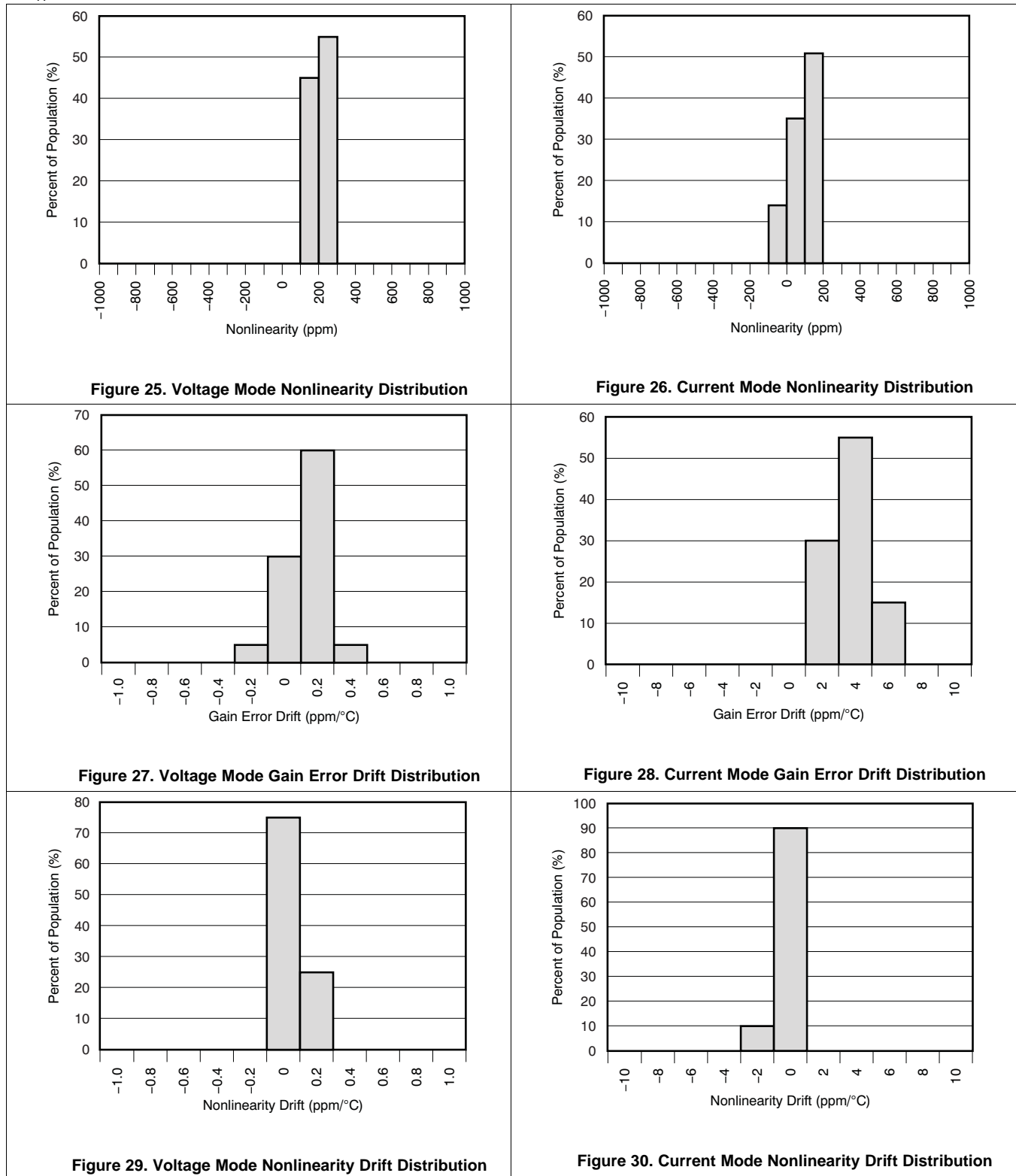

Figure 24. Current Mode Gain Error Distribution

Typical Characteristics (continued)

at $T_A = 25^\circ\text{C}$ and $V_+ = \pm 20\text{ V}$, unless otherwise noted



Typical Characteristics (continued)

at $T_A = 25^\circ\text{C}$ and $V_+ = \pm 20\text{ V}$, unless otherwise noted

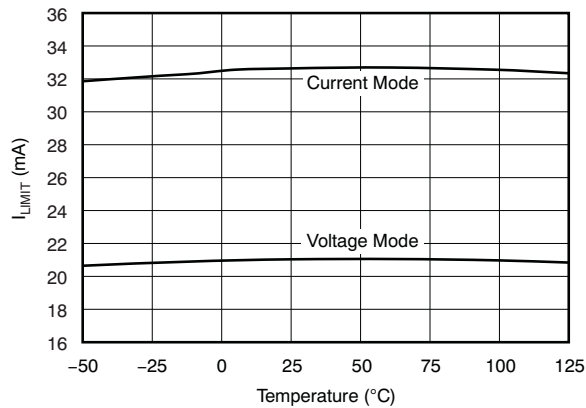

Figure 31. Positive Current Limit vs Temperature

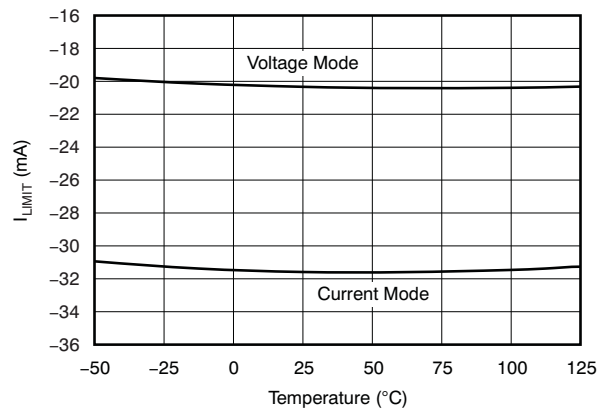
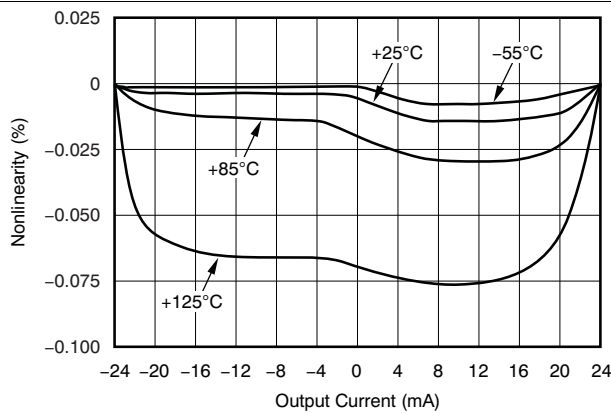
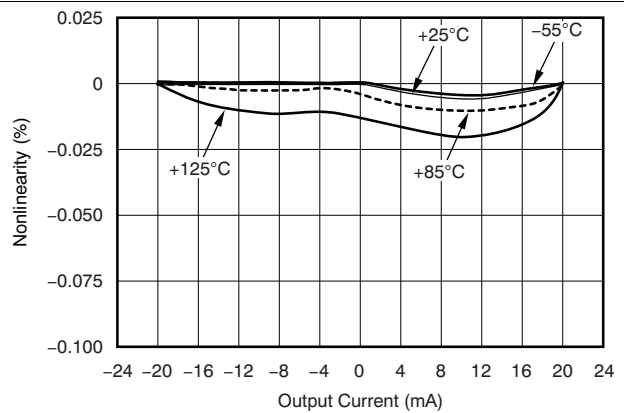

Figure 32. Negative Current Limit vs Temperature



(±24-mA End Point Calibration)

Figure 33. Nonlinearity vs Output Current



(±20-mA End Point Calibration)

Figure 34. Nonlinearity vs Output Current

7 Detailed Description

7.1 Overview

Built on a robust high-voltage BiCMOS process, the XTR305 is designed to interface the 5-V or 3-V supply domain used for processors, signal converters, and amplifiers to the high-voltage and high-current industrial signal environment. The device is specified for up to ± 20 -V supply, but can also be powered asymmetrically (for example, +24 V and -5 V). It is designed to allow insertion of external circuit protection elements and drive large capacitive loads.

7.2 Functional Block Diagrams

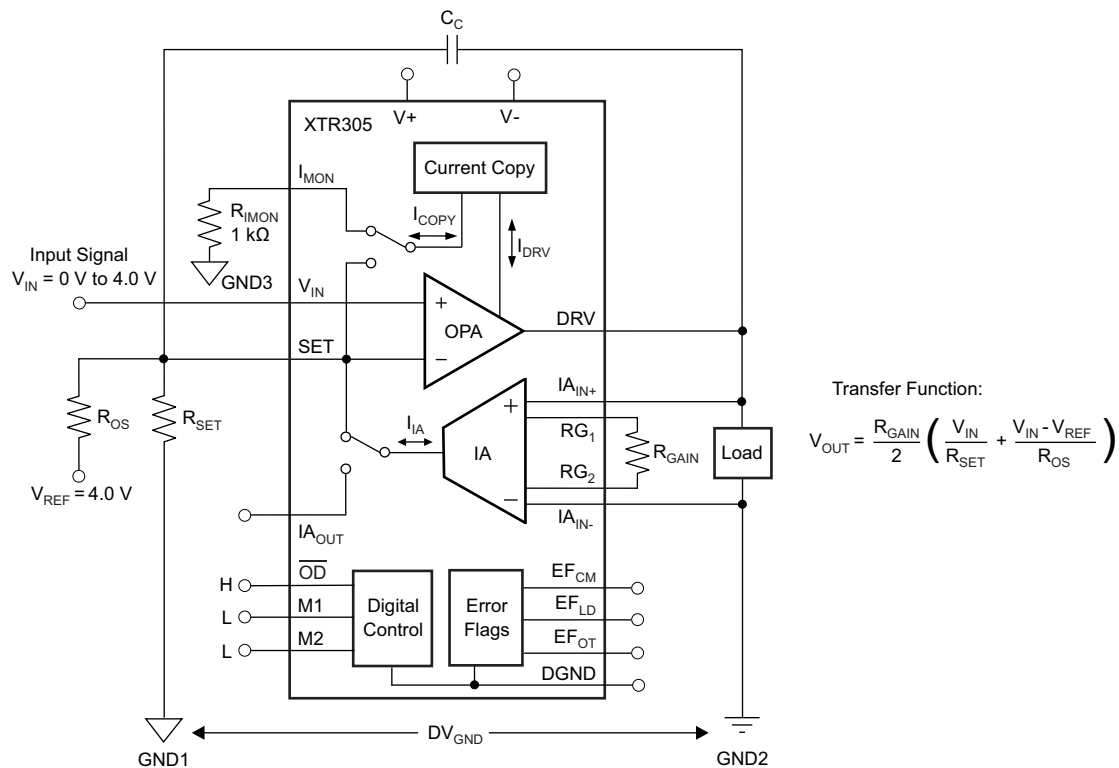

Copyright © 2017, Texas Instruments Incorporated

Figure 35. Standard Circuit for Voltage Output Mode

Functional Block Diagrams (continued)

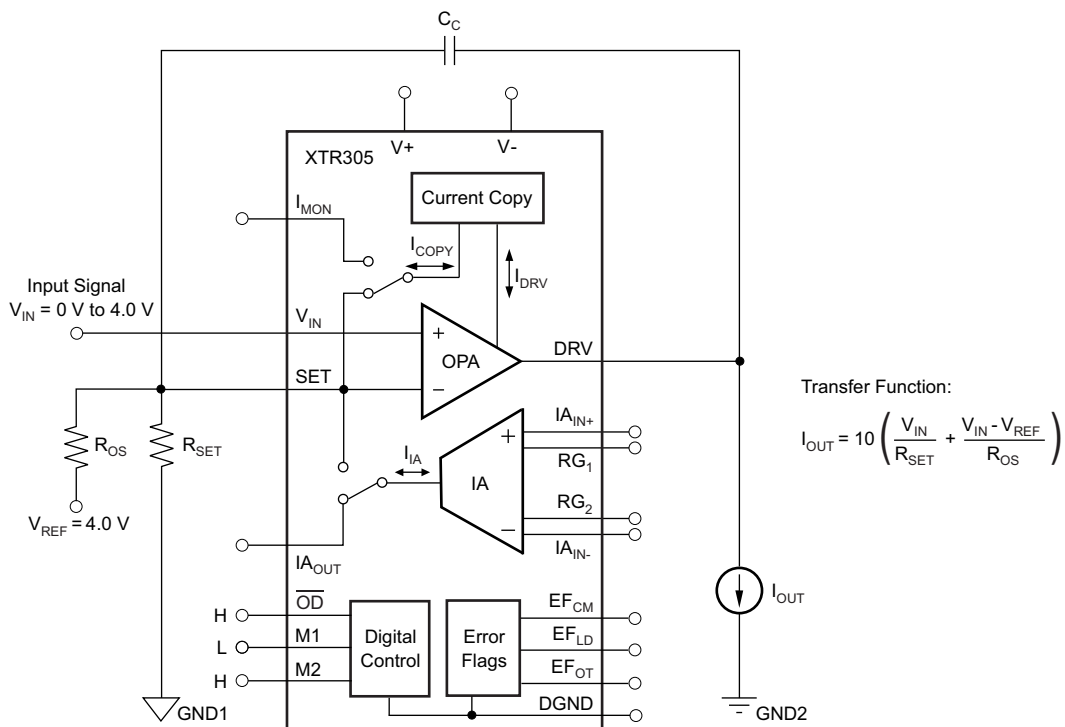

Copyright © 2017, Texas Instruments Incorporated

Figure 36. Standard Circuit for Current Output Mode

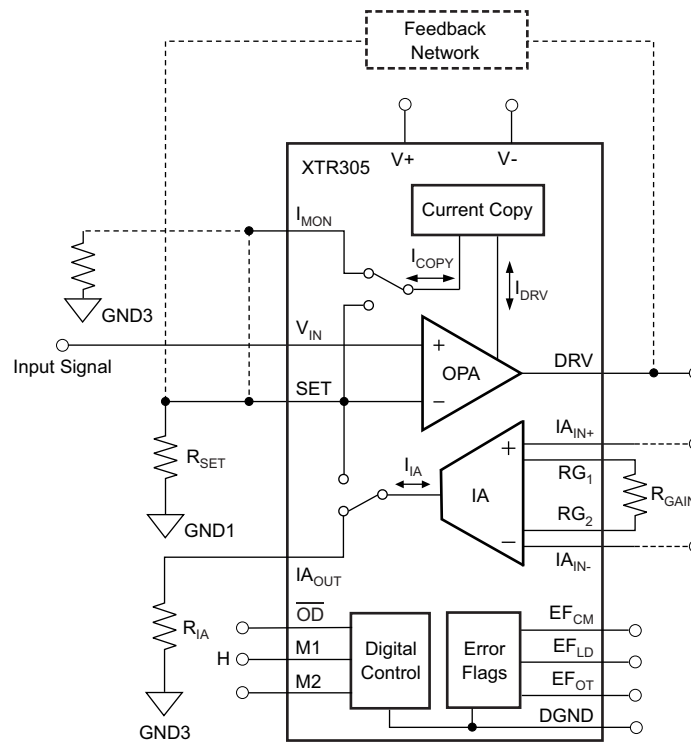
Functional Block Diagrams (continued)

Copyright © 2017, Texas Instruments Incorporated

Figure 37. Standard Circuit for Externally Configured Mode
7.3 Feature Description
7.3.1 Functional Features

The XTR305 provides two basic functional blocks: an instrumentation amplifier (IA) and a driver that is a unique operational amplifier (OPA) for current or voltage output. This combination represents an analog output stage which can be digitally configured to provide either current or voltage output to the same terminal pin. Alternatively, it can be configured for independent measurement channels.

Three open collector error signals are provided to indicate output related errors such as overcurrent or open-load (EF_{LD}) or exceeding the common-mode input range at the IA inputs (EF_{CM}). An overtemperature flag (EF_{OT}) can be used to control output disable to protect the circuit. The monitor outputs (I_{MON} and IA_{OUT}) and the error flags offer optimal testability during operation and configuration. The I_{MON} output represents the current flowing into the load in voltage output mode, while the IA_{OUT} represents the voltage across the connectors in current output mode. Both monitor outputs can be connected together when used in current or voltage output mode because the monitor signals are multiplexed accordingly.

7.3.2 Current Monitor

In current output mode ($M2 = \text{high}$), the XTR305 provides high output impedance. A precision current mirror generates an exact 1/10th copy of the output current and this current is either routed to the summing junction of the OPA to close the feedback loop (in the current output mode) or to the I_{MON} pin for output current monitoring in other operating modes.

The high accuracy and stability of this current split results from a cycling chopper technique. This design eliminates the need for a precise shunt resistor or a precise shunt voltage measurement, which would require high common-mode rejection performance.

Feature Description (continued)

During a saturation condition of the DRV output (the error flag is active), the monitor output (I_{MON}) shows a current peak because the loop opens. Glitches from the current mirror chopper appear during this time in the monitor signal. This part of the signal cannot be used for measurement.

7.3.3 Error Flags

The XTR305 is designed for testability of its proper function and allows observation of the conditions at the load connection without disrupting service.

If the output signal is not in accordance to the transfer function, an error flag is activated (limited by the dynamic response capabilities). These error flags are in addition to the monitor outputs, I_{MON} and IA_{OUT} , which allow the momentary output current (in voltage mode) or output voltage (in current mode) to be read back.

This combination of error flag and monitor signal allows easy observation of the XTR305 for function and working condition, providing the basis for not only remote control, but also for remote diagnosis.

All error flags of the XTR305 have open collector outputs with a weak pullup of approximately 1 μ A to an internal 5 V. External pullup resistors to the logic voltage are required when driving 3-V or 5-V logic.

The output sink current should not exceed 5 mA. This is just enough to directly drive optical-couplers, but a current-limiting resistor is required.

There are three error flags:

1. **IA Common-Mode Over Range (EF_{CM}):** goes low as soon as the inputs of the IA reach the limits of the linear operation for the input voltage. This flag shows noise from the saturated current mirrors which can be filtered with a capacitor to GND.
2. **Load Error (EF_{LD}):** indicates fault conditions driving voltage or current into the load. In voltage output mode it monitors the voltage limits of the output swing and the current limit condition caused from short or low load resistance. In current output mode it indicates a saturation into the supply rails from a high load resistance or open load.
3. **Overtemperature Flag (EF_{OT}):** a digital output that goes low if the chip temperature reaches a temperature of 140°C and resets as soon as it cools down to 125°C. It does not automatically shut down the output; it allows the user system to take action on the situation. If desired, this output can be connected to output disable (\overline{OD}) which disables the output and therefore removes the source of power. This connection acts like an automatic shut down, but requires a 2.2-k Ω external pullup resistor to safely override the internal current sources. The IA channel is not affected, which allows continuous observation of the voltage at the output.

7.3.4 Power On/Off Glitch

When power is turned on or off, most analog amplifiers generate some glitching of the output because of internal circuit thresholds and capacitive charges. Characteristics of the supply voltage, as well as its rise and fall time, directly influence output glitches. Load resistance and capacitive load also affect the amplitude.

The output disable control (\overline{OD}) cannot fully suppress glitches during power-on and power-off, but reduces the energy significantly. The glitch consists of a small amount of current and capacitive charge (voltage) that reacts with the resistive and capacitive load. The bias current of the IA inputs that are normally connected to the output also generate a voltage across the load.

Feature Description (continued)

Figure 38 indicates no glitches when transitioning between disable and enable. This measurement is made with a load resistance of 1 kΩ and tested in the circuit configuration of Figure 40.

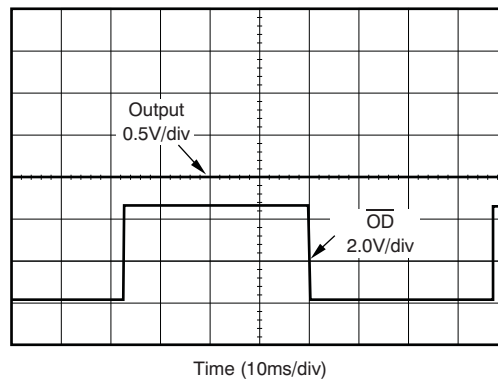
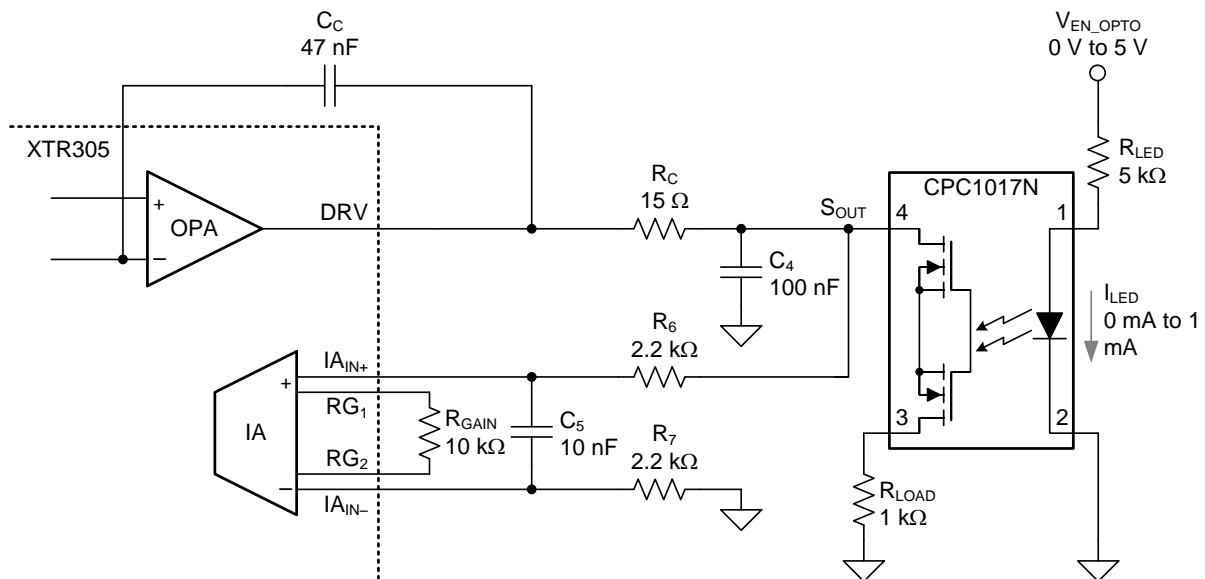

Figure 38. Output Signal During Toggle of \overline{OD}

When the power is off or with low supply, the output is diode clamped to the momentary supply voltage, but can float while output disabled within those limits unless terminated. Only an external switch (relays or opto-relays) can isolate the output under such conditions. Refer to Figure 39 for an illustration of this configuration. The same consideration applies if low impedance zero output is required, even during power off.



Copyright © 2017, Texas Instruments Incorporated

Figure 39. Example for Opto-Relay Output Isolation

7.4 Device Functional Modes

The XTR305 has a three functional modes: voltage output mode as shown in Figure 35, current output mode as shown in Figure 36, and externally configured mode as shown in Figure 37.

8 Application and Implementation

NOTE

Information in the following applications sections is not part of the TI component specification, and TI does not warrant its accuracy or completeness. TI's customers are responsible for determining suitability of components for their purposes. Customers should validate and test their design implementation to confirm system functionality.

8.1 Application Information

The following sections provide details regarding the typical application of the XTR305 using three different functional modes: voltage output mode as shown in Figure 35, current output mode as shown in Figure 36, and externally configured mode as shown in Figure 37.

8.2 Typical Application

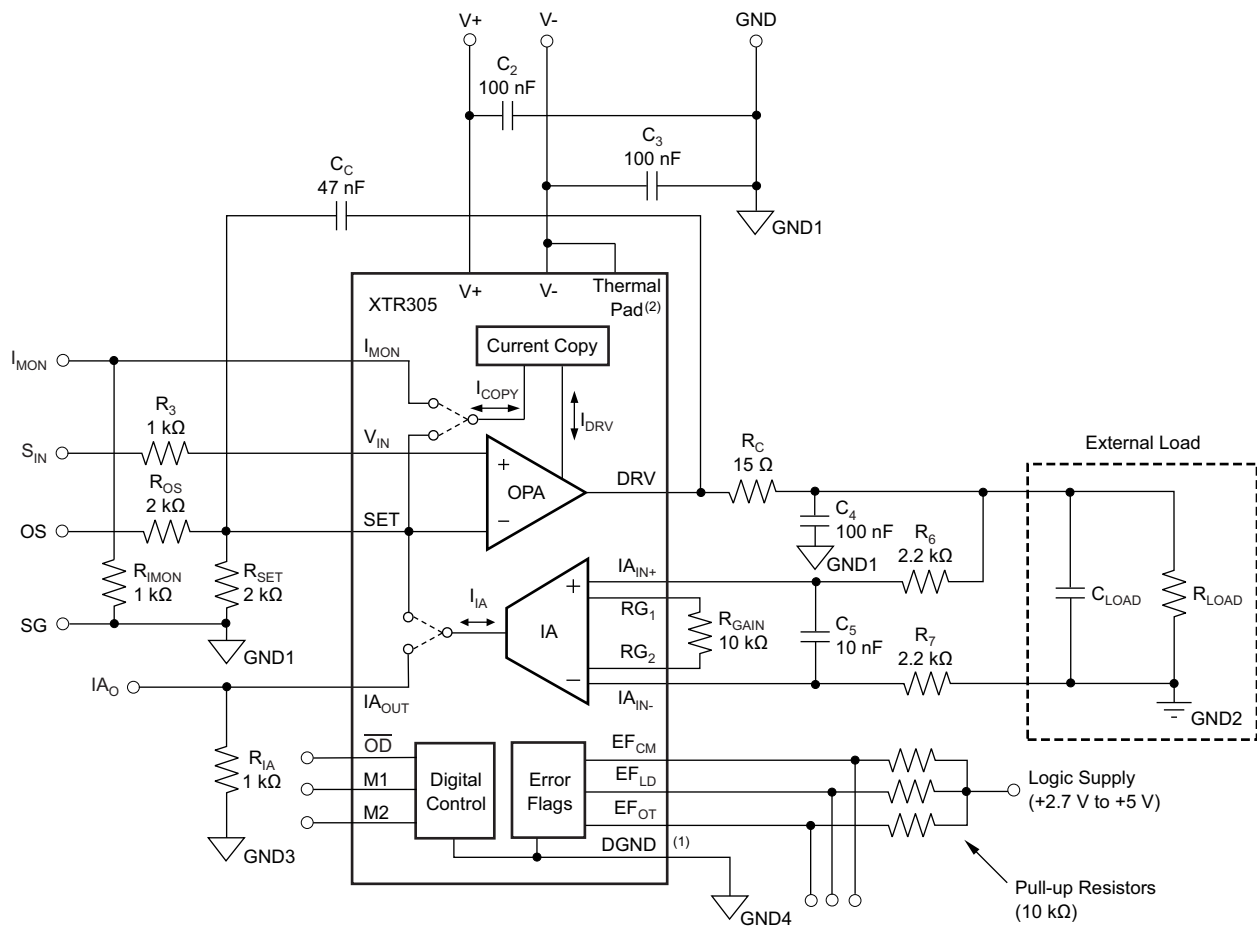

Copyright © 2017, Texas Instruments Incorporated

- (1) See the [Electrical Characteristics: Power and Digital](#) and [Digital I/O and Ground Considerations](#) section for operating limits of DGND.
- (2) Connect thermal pad to V-.

Figure 40. Standard Circuit Configuration

8.2.1 Design Requirements

Consider the following information during XTR305 circuit configuration:

- Recommended bypassing: 100 nF or more for supply bypassing at each supply.
- R_{IMON} can be in the $k\Omega$ range or short-circuited if not used. Do not leave this current output unconnected — it would saturate the internal current source. The current at this I_{MON} output is $I_{DRV} / 10$. Therefore, $V_{IMON} = R_{IMON} (I_{DRV} / 10)$.
- R_3 is not required but can match R_{SET} (or $R_{SET} || R_{OS}$) to compensate for the bias current.
- R_{IA} can be short-circuited if not used. Do not leave this current output unconnected. R_{GAIN} is selected to 10 $k\Omega$ to match the output of 10 V with 20 mA for the equal input signal.
- R_C ensures stability for unknown load conditions and limits the current into the internal protection diodes. C_4 helps protect the device. Overvoltage clamp diodes (standard 1N4002) might be necessary to protect the output.
- R_6 , R_7 , and C_5 protect the IA.
- R_{LOAD} and C_{LOAD} represent the load resistance and load capacitance.
- R_{SET} defines the transfer gain. It can be split to allow a signal offset and, therefore, allow a 5-V single-supply digital-to-analog converter (DAC) to control a ± 10 -V or ± 20 -mA output signal.

The XTR305 can be used with asymmetric supply voltages; however, the minimum negative supply voltage must be equal to or more negative than -3 V (typically -5 V). This supply value ensures proper control of 0 V and 0 mA with wire resistance, ground offsets, and noise added to the output. For positive output signals, the current requirement from this negative voltage source is less than 5 mA.

GND1 through GND4 must be selected to fulfill specified operating ranges. DGND must be in the range of $(V-) \leq DGND \leq (V+) - 7$ V.

8.2.2 Detailed Design Procedure

8.2.2.1 Voltage Output Mode

In voltage output mode (M1 and M2 are connected low or left unconnected), the feedback loop through the IA provides high impedance remote sensing of the voltage at the destination, compensating the resistance of a protection circuit, switches, wiring, and connector resistance. The output of the IA is a current that is proportional to the input voltage. This current is internally routed to the OPA summing junction through a multiplexer, as shown in [Figure 41](#).

A 1:10 copy of the output current of the OPA can be monitored at the I_{MON} pin. This output current and the known output voltage can be used to calculate the load resistance or load power.

During an output short-circuit or an overcurrent condition the XTR305 output current is limited and EF_{LD} (load error, active low) flag is activated.

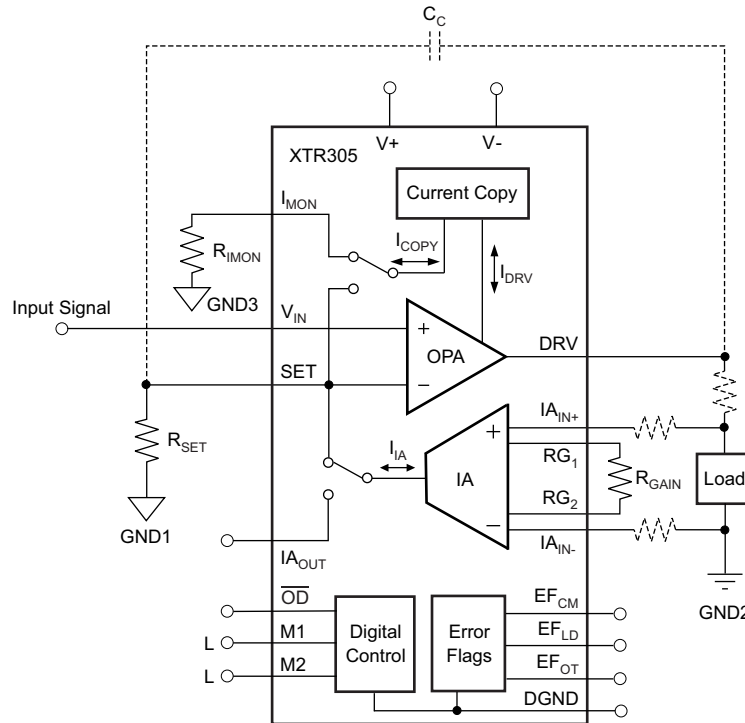

Copyright © 2017, Texas Instruments Incorporated

Figure 41. Simplified Voltage Output Mode Configuration

Applications not requiring the remote sense feature can use the OPA in stand-alone operation (M1 = high). In this case, the IA is available as a separate input channel.

The IA gain can be set by two resistors, R_{GAIN} and R_{SET} (Equation 1):

$$V_{OUT} = \frac{R_{GAIN}}{2R_{SET}} V_{IN} \quad (1)$$

or when adding an offset, V_{REF} , to get bidirectional output with a single-ended input shown in Equation 2:

$$V_{OUT} = \frac{R_{GAIN}}{2} \left(\frac{V_{IN}}{R_{SET}} + \frac{V_{IN} - V_{REF}}{R_{OS}} \right) \quad (2)$$

The R_{SET} resistor is also used in current output mode. Therefore, it is useful to define R_{SET} for the current mode, then set the ratio between current and voltage span with R_{GAIN} .

8.2.2.2 Current Output Mode

The XTR305 does not require a shunt resistor for current control because it uses a precise current mirror arrangement.

In current output mode (M1 connected low, or left unconnected and M2 connected high), a precise copy of 1/10th of the output is internally routed back to the summing junction of the OPA through a multiplexer, closing the control loop for the output current.

The OPA driver can deliver more than ± 24 mA within a wide output voltage range. An open-output condition or high-impedance load that prevents the flow of the required current activates the EF_{LD} flag and the IA can become overloaded and draw greater than 7-mA saturation current.

While in current output mode, a current (I_{IA}) that is proportional to the voltage at the IA input is routed to IA_{OUT} and can be used to monitor the load voltage. A resistor converts this current into voltage. This arrangement makes level shifting easy.

Alternatively, the IA can be used as an independent monitoring channel. If this output is not used, connect it to GND to maintain proper function of the monitor stage, as shown in [Figure 42](#).

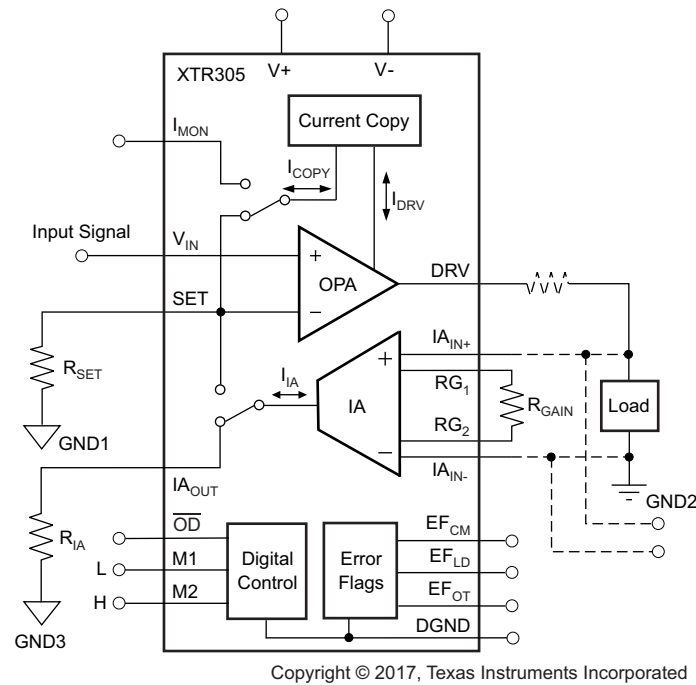

Figure 42. Simplified Current Output Mode Configuration

The transconductance (gain) can be set by the resistor, R_{SET} , according to [Equation 3](#):

$$I_{OUT} = \frac{10}{R_{SET}} V_{IN} \quad (3)$$

or when adding an offset V_{REF} to get bidirectional output with a single-ended input shown in [Equation 4](#):

$$I_{OUT} = 10 \left(\frac{V_{IN}}{R_{SET}} + \frac{V_{IN} - V_{REF}}{R_{OS}} \right) \quad (4)$$

8.2.2.3 Input Signal Connection

It is possible to drive the XTR305 with a unidirectional input signal and still get a bidirectional output by adding an additional resistor, R_{OS} , and an offset voltage signal, V_{REF} . It can be a mid-point voltage or a signal to shift the output voltage to a desired value.

This design is illustrated in Figure 43a, Figure 43b, and Figure 43c. As with a normal operational amplifier, there are several options for offset-shift circuits. The input can be connected for inverting or noninverting gain. Unlike many op amp input circuits, however, this configuration uses current feedback, which removes the voltage relationship between the noninverting input and output potential because there is no feedback resistor.

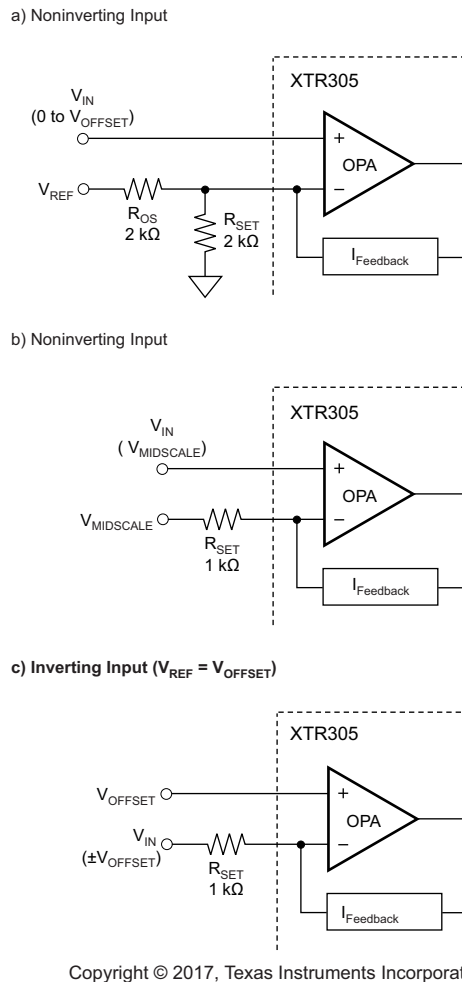

Figure 43. Circuit Options for Op Amp Output Level Shifting

The input bias current effect on the offset voltage can be reduced by connecting a resistor in series with the positive input that matches the approximate resistance at the negative input. This resistor placed close to the input pin acts as a damping element and makes the design less sensitive to RF noise. See R_3 in Figure 40.

8.2.2.4 Externally-Configured Mode: OPA and IA

It is possible to use the precision of the operational amplifier (OPA) and instrumentation amplifier (IA) independently from each other by configuring the digital control pins (M1 high). In this mode, the IA output current is routed to IA_{OUT} and the copy of the OPA output current is routed to I_{MON} , as shown in Figure 37.

This mode allows external configuration of the analog signal routing and feedback loop.

The current output IA has high input impedance, low offset voltage and drift, and very high common-mode rejection ratio. An external resistor (R_{IA}) can be used to convert the output current of the IA (I_{IA}) to an output voltage. The gain is given by Equation 5:

$$I_{IA} = \frac{2}{R_{GAIN}} V_{IN} \text{ or } V_{IA} = \frac{2R_{IA}}{R_{GAIN}} V_{IN} \quad (5)$$

The OPA provides low drift and high voltage output swing that can be used like a common operational amplifier by connecting a feedback network around it. In this mode, the copy of the output current is available at the I_{MON} pin (it includes the current into the feedback network). It provides an output current limit for protection, which can be set between two ranges by M2. The error flag indicates an overcurrent condition, as well as indicating driving the output into the supply rails.

Alternatively, the feedback can be closed through the I_{MON} pin to create a precise voltage-to-current converter.

8.2.2.5 Driver Output Disable

The OPA output (DRV) can be switched to a high-impedance mode by driving the \overline{OD} control pin low. This input can be connected to the overtemperature flag, EF_{OT} , and a pullup resistor to protect the IC from over-temperature by disconnecting the load.

The output disable mode can be used to sense and measure the voltage at the IA input pins without loading from the DRV output. This mode allows testing of any voltage present at the I/O connector. However, consider the bias current of the IA input pins.

The digital control inputs, M1 and M2, set the four operation modes of the XTR305 as shown in [Table 1](#). When M1 is asserted low, M2 determines voltage or current mode and the corresponding appropriate current limit (I_{SC}) setting. When M1 is high, the internal feedback connections are opened; IA_{OUT} and I_{MON} are both connected to the output pins; and M2 only determines the current limit (I_{SC}) setting.

M1 and M2 are pulled low internally with 1 μ A. Terminate these two pins to avoid noise coupling. Output disable (\overline{OD}) is internally pulled high with approximately 1 μ A. When connecting \overline{OD} to EF_{OT} , a 2.2-k Ω pullup resistor is recommended.

Table 1. Summary of Configuration Modes⁽¹⁾

| M1 | M2 | MODE | DESCRIPTION |
|----|----|-----------|---|
| L | L | V_{OUT} | Voltage output mode, $I_{SC} = 20$ mA |
| L | H | I_{OUT} | Current output mode, $I_{SC} = 32$ mA |
| H | L | Ext | IA and I_{MON} on external pins, $I_{SC} = 20$ A |
| H | H | Ext | IA and I_{MON} on external pins, $I_{SC} = 32$ mA |

(1) \overline{OD} is a control pin independent of M1 or M2.

8.2.2.6 Driving Capacitive Loads and Loop Compensation

For normal operation, the driver OPA and the IA are connected in a closed loop for voltage output. In current output mode, the current copy closes the loop directly.

In current output mode, loop compensation is not critical, even for large capacitive loads. However, in voltage output mode, the capacitive load, together with the source impedance and the impedance of the protection circuit, generates additional phase lag. The IA input might also be protected by a low-pass filter that influences phase in the closed loop.

The loop compensation low-pass filter consists of C_C and the parallel resistance of R_{OS} and R_{SET} . For loop stability with large capacitive load, the external phase shift has to be added to the OPA phase. With C_C , the voltage gain of the OPA has to approach zero at the frequency where the total phase approaches $180^\circ + 135^\circ$.

The best stability for large capacitive loads is provided by adding a small resistor, R_C (15 Ω). See the [Output Protection](#) section.

An empirical method of evaluation is using a square wave input signal and observing the settling after transients. Use small signal amplitudes only—steep signal edges cause excessive current to flow into the capacitive load and may activate the current limit, which hides or prevents oscillation. A small-signal oscillation can be hidden from large capacitive loads, but observing the I_{MON} output on an appropriate resistor (use a similar value like $R_{SET} || R_{OS}$) would indicate stability issues. Note that noise pulses at I_{MON} during overload (EF_{LD} active) are normal and are caused by cycling of the current mirror.

The voltage output mode includes the IA in the loop. An additional low-pass filter in the input reverses the phase and therefore increases the signal bandwidth of the loop, but also increases the delay. Again, loop stability has to be observed. Overloading the IA disconnects the closed loop and the output voltage rails.

8.2.2.7 Internal Current Sources, Switching Noise, and Settling Time

The accuracy of the current output mode and the DC performance of the IA rely on dynamically-matched current mirrors.

Identical current sources are rotated to average out mismatch errors. It can take several clock cycles of the internal 100-kHz oscillator (or a submultiple of that frequency) to reach full accuracy. This may dominate the settling time to the 0.1% accuracy level and can be as much as 100 μs in current output mode or 40 μs in voltage output mode.

A small portion of the switching glitches appear at the DRV output, and also at the I_{MON} and IA_{MON} outputs. The standard circuit configuration, with R_C, C₄, and C_C, which are required for loop compensation and output protection, also helps reduce the noise to negligible levels at the signal output. If necessary, the monitor outputs can be filtered with a shunt capacitor.

8.2.2.8 IA Structure, Voltage Monitor

The instrumentation amplifier has high-impedance NPN transistor inputs that do not load the output signal, which is especially important in current output mode. The output signal is a controlled current that is multiplexed either to the SET pin (to close the voltage output loop) or to IA_{OUT} (for external access).

The principal circuit is shown in Figure 44. The two input buffer amplifiers reproduce the input difference voltage across R_{GAIN}. The resulting current through this resistor is bidirectionally mirrored to the output. That mirroring results in the transfer function of Equation 6:

$$I_{IA} = IA_{OUT} = 2 \frac{(IA_{IN+} - IA_{IN-})}{R_{GAIN}} \tag{6}$$

The accuracy and drift of R_{GAIN} defines the accuracy of the voltage to current conversion. The high accuracy and stability of the current mirrors result from a cycling chopper technique.

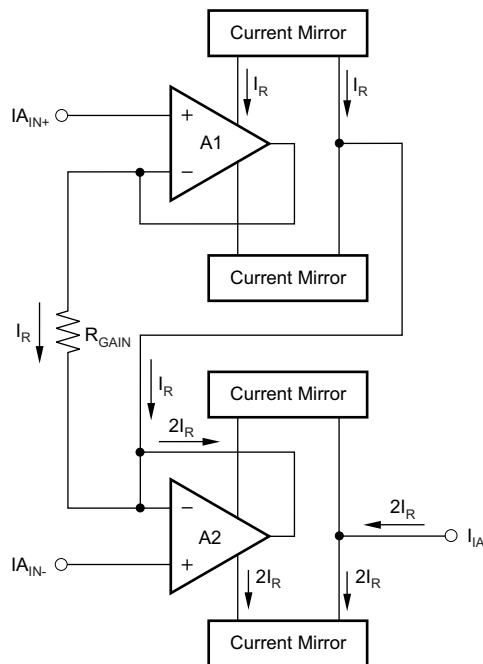

Copyright © 2017, Texas Instruments Incorporated

Figure 44. IA Block Diagram

The output current, I_{AOUT} , of the instrumentation amplifier is limited to protect the internal circuitry. This current limit has two settings controlled by the state of M2 (see [Electrical Characteristics: Instrumentation Amplifier \(IA\)](#), Short-Circuit Current specification).

NOTE

If R_{SET} is too small, the current output limitation of the instrumentation amplifier can disrupt the closed loop of the XTR305 in voltage output mode.

With M2 = low, the nominal R_{GAIN} of 10 k Ω allows an input voltage of 20 V_{PP}, which produces an output current of 4 mA_{PP}. When using lower resistors for R_{GAIN} that can allow higher currents, the IA output current limitation must be taken into account.

8.2.2.9 Digital I/O and Ground Considerations

The XTR305 offers voltage output mode, current output mode, external configuration, and instrumentation mode (voltage input). In addition, the internal feedback mode can be disconnected and external loop connections can be made. These modes are controlled by M1 and M2 (see [Table 1](#)). The \overline{OD} input pin controls enable or disable of the output stage (\overline{OD} is active low).

The digital I/O is referenced to DGND and signals on this pin must remain within 5 V of the DGND potential. This DGND pin carries the output low-current (sink current) of the logic outputs. DGND can be connected to a potential within the supply voltage but needs to be 8 V below the positive supply. Proper connection avoids current from the digital outputs flowing into the analog ground.

CAUTION

The DGND has normally reverse-biased diodes connected to the supply. Therefore, high and destructive currents could flow if DGND is driven beyond the supply rails by more than a diode forward voltage. *Avoid this condition during power on and power off.*

8.2.2.10 Output Protection

The XTR305 is intended to operate in a harsh industrial environment. Therefore, a robust semiconductor process was chosen for this design. However, some external protection is still required.

The instrumentation amplifier inputs can be protected by external resistors that limit current into the protection cell behind the IC pins, as shown in [Figure 45](#). This cell conducts to the power-supply connection through a diode as soon as the input voltage exceeds the supply voltage. The circuit configuration example shows how to arrange these two external resistors.

The bias current is best cancelled if both resistors are equal. The additional capacitor reduces RF noise in the input signal to the IA.

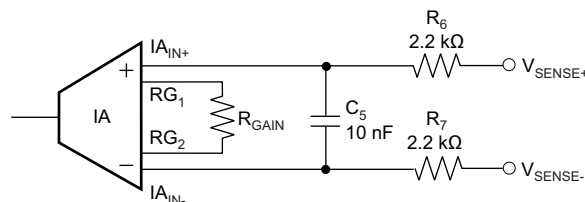
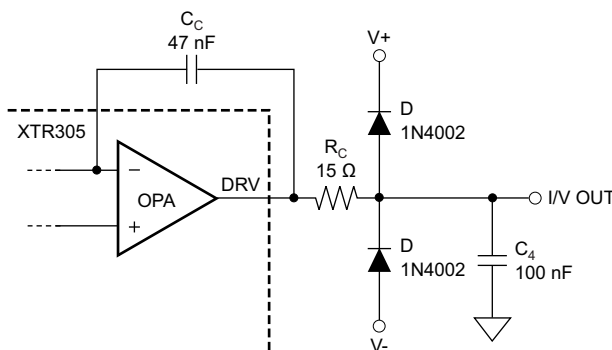

Figure 45. Current-Limiting Resistors

The load connection to the DRV output must be low impedance; therefore, external protection diodes may be necessary to handle excessive currents, as shown in [Figure 46](#). The internal protection diodes start to conduct earlier than a normal external PN-type diode because they are affected by the higher die temperature. Therefore, either Schottky diodes are required, or an additional resistor (R_C) can be placed in series with the input. An example of this protection is shown in [Figure 46](#). Assuming the standard diodes limit the voltage to 1.4 V and the internal diodes clamp at 0.7 V, this resistor can limit the current into the internal protection diodes to 50 mA shown in [Equation 7](#):

$$\frac{(1.4V - 0.7V)}{15\Omega} = 47mA \tag{7}$$

R_C is also part of the recommended loop compensation. C₄ helps protect the output against RFI and high-voltage spikes.



Copyright © 2017, Texas Instruments Incorporated

Figure 46. Example for DRV Output Protection

8.2.3 Application Curves

The nonlinearity of the XTR305 when operating in current output mode is shown in Figure 47 and Figure 48.

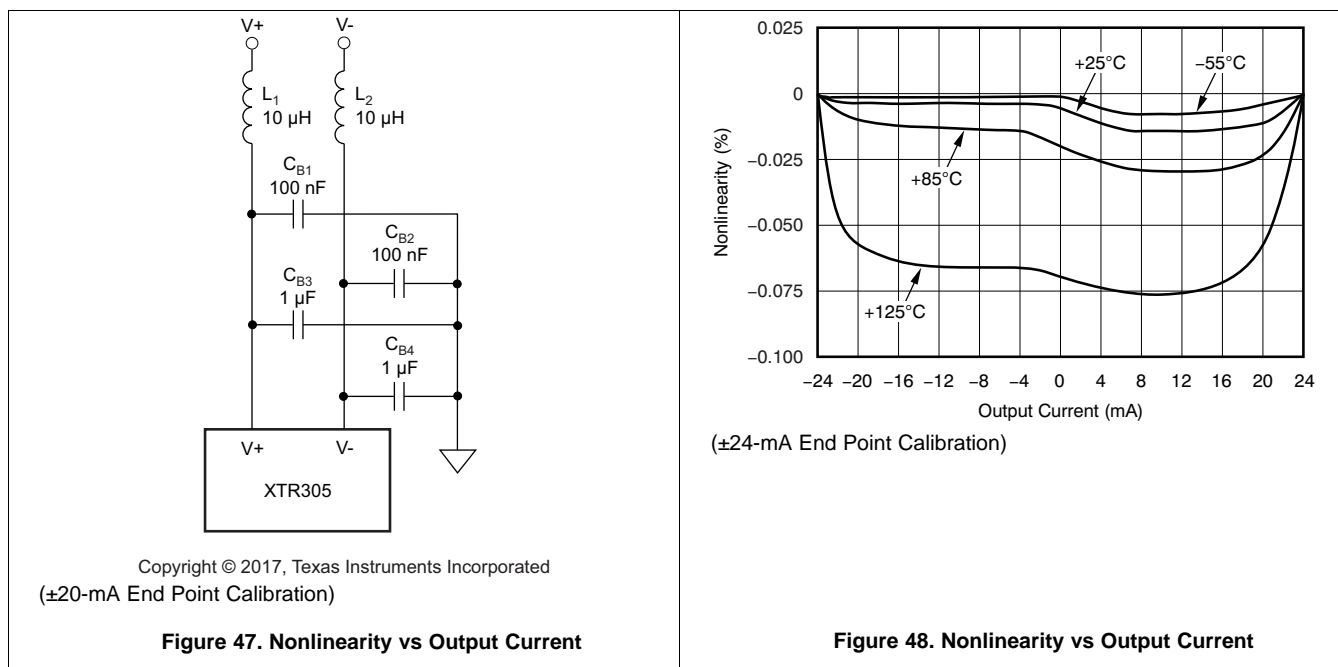

9 Power Supply Recommendations

Built on a robust high-voltage BiCMOS process, the XTR305 is designed to interface the 5-V or 3-V supply domain used for processors, signal converters, and amplifiers to the high-voltage and high-current industrial signal environment. The device is specified for up to ±20-V supply, but can also be powered asymmetrically (for example, +24 V and -5 V). XTR305 is designed to allow insertion of external circuit protection elements and drive large capacitive loads.

10 Layout

10.1 Layout Guidelines

Supply bypass capacitors must be close to the package and connected with low-impedance conductors. Avoid noise coupled into R_{GAIN} , and observe wiring resistance. For thermal management, see the [VQFN Package and Heat Sinking](#) section.

Layout for the XTR305 is not critical; however, its internal current chopping works best with good (low dynamic impedance) supply decoupling. Therefore, avoid through-hole contacts in the connection to the bypass capacitors or use multiple through-hole contacts. Switching noise from power supplies should be filtered enough to reduce influence on the circuit. Small resistors (2- Ω , for example) or damping inductors in series with the supply connection (between the DC-DC converter and the XTR circuit) act as a decoupling filter together with the bypass capacitor as shown in [Figure 49](#).

Resistors connected close to the input pins help dampen environmental noise coupled into conductor traces. Therefore, place the OPA input- and IA input-related resistors close to the package. Also, avoid additional wire resistance in series to R_{SET} , R_{OS} , and R_{GAIN} (observe the reliability of the through-hole contacts), because this resistance could produce gain and offset error as well as drift; 1 Ω is already 0.1% of the 1-k Ω resistor.

The exposed lead-frame die pad on the bottom of the package must be connected to V^- , pin 11 (see the [VQFN Package and Heat Sinking](#) section for more details).

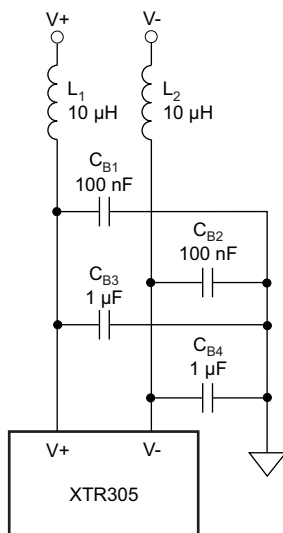

Copyright © 2017, Texas Instruments Incorporated

Figure 49. Suggested Supply Decoupling for Noisy Chopper-Type Supplies

10.2 Layout Example

A detailed layout example can be found in the technical document [XTR300EVM](#). This document is available for download at www.ti.com. The example layout is also shown in [Figure 50](#).

Layout Example (continued)

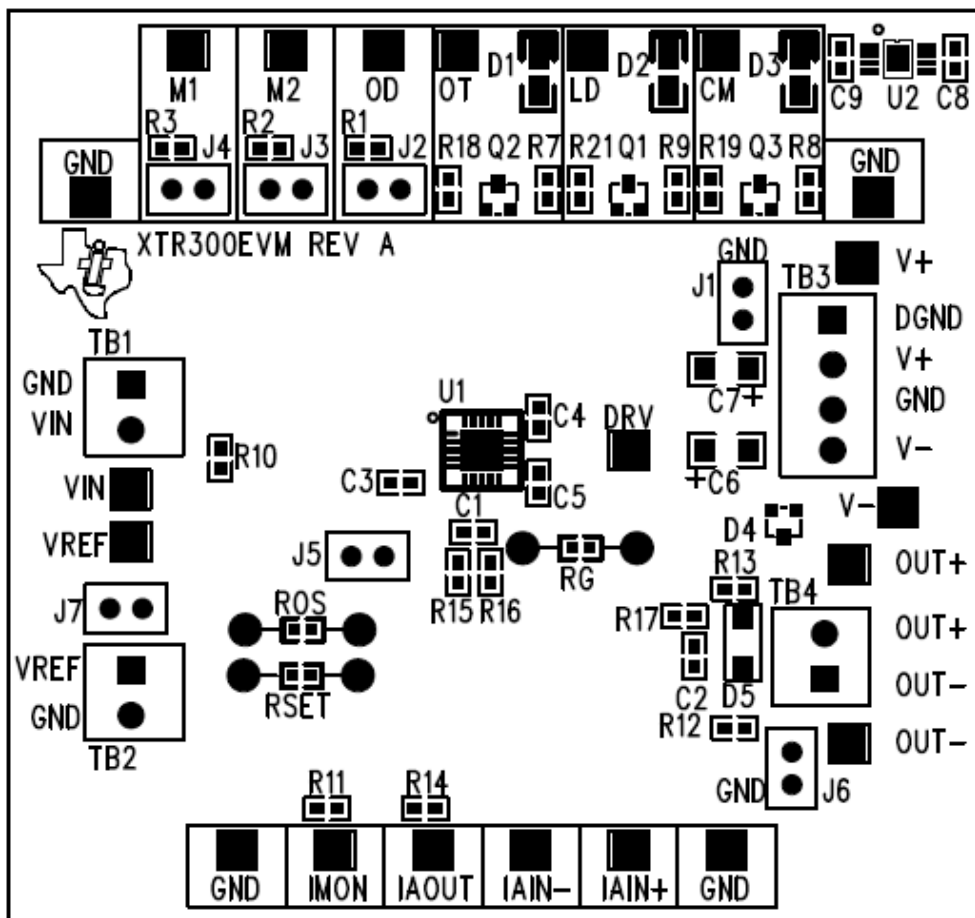

Figure 50. Layout Example

10.3 VQFN Package and Heat Sinking

The XTR305 is available in a VQFN package. This leadless, near-chip-scale package maximizes board space and enhances thermal and electrical characteristics of the device through an exposed thermal pad.

Packages with an exposed thermal pad are specifically designed to provide excellent power dissipation, but printed circuit board (PCB) layout greatly influences overall heat dissipation. The thermal resistance from junction-to-ambient (θ_{JA}) is specified for the packages with the exposed thermal pad soldered to a normalized PCB, as described in the technical brief [PowerPAD™ Thermally-Enhanced Package](#). See also [EIA/JEDEC Specifications JESD51-0 to 7](#), [VQFN/SON PCB Attachment](#), and [Quad Flatpack No-Lead Logic Packages](#). These documents are available for download at www.ti.com.

NOTE

All thermal models have an accuracy variation of $\pm 20\%$.

Component population, layout of traces, layers, and air flow strongly influence heat dissipation. Worst-case load conditions should be tested in the real environment to ensure proper thermal conditions. Minimize thermal stress for proper long-term operation with a junction temperature well below $+125^{\circ}\text{C}$.

The exposed lead-frame die pad on the bottom of the package must be connected to the V- pin.

10.4 Power Dissipation

Power dissipation depends on power supply, signal, and load conditions. It is dominated by the power dissipation of the output transistors of the OPA. For DC signals, power dissipation is equal to the product of output current, I_{OUT} and the output voltage across the conducting output transistor ($V_S - V_{OUT}$).

It is very important to note that the temperature protection does not shut the device down in overtemperature conditions, unless the EF_{OT} pin is connected to the output enable pin \overline{OD} ; see the [Driver Output Disable](#) section.

The power that can be safely dissipated in the package is related to the ambient temperature and the heat sink design and conditions. The VQFN package with an exposed thermal pad is specifically designed to provide excellent power dissipation, but board layout greatly influences the heat dissipation.

To appropriately determine the required heat sink area, calculate required power dissipation; also consider the relationship between power dissipation and thermal resistance to minimize overheat conditions and allow for reliable long-term operation.

The heat-sinking efficiency can be tested using the EF_{OT} output signal. This output goes low at nominally 140°C junction temperature (assume 6% tolerance). With full power dissipation (for example, maximum current into a 0- Ω load), the ambient temperature can be slowly raised until the OT flag goes low. This flag would indicate the minimum heat sinking for the usable operation condition.

The recommended landing pattern for the VQFN package is shown at the end of this data sheet.

11 器件和文档支持

11.1 文档支持

11.1.1 相关文档

如需相关文档，请参阅：

- [《PowerPAD™ 散热增强型封装》](#)
- [EIA/JEDEC 规范 JESD51-0 至 7、《VQFN/SON PCB 连接》](#)
- [《四方扁平无引线逻辑器件封装》](#)

11.2 接收文档更新通知

要接收文档更新通知，请导航至 TI.com.cn 上的器件产品文件夹。请单击右上角的提醒我进行注册，即可每周接收产品信息更改摘要。有关更改的详细信息，请查看任何已修订文档中包含的修订历史记录。

11.3 社区资源

下列链接提供到 TI 社区资源的连接。链接的内容由各个分销商“按照原样”提供。这些内容并不构成 TI 技术规范，并且不一定反映 TI 的观点；请参阅 TI 的 [《使用条款》](#)。

TI E2E™ 在线社区 *TI 的工程师对工程师 (E2E) 社区*。此社区的创建目的在于促进工程师之间的协作。在 e2e.ti.com 中，您可以咨询问题、分享知识、拓展思路并与同行工程师一道帮助解决问题。

设计支持 *TI 参考设计支持* 可帮助您快速查找有帮助的 E2E 论坛、设计支持工具以及技术支持的联系信息。

11.4 商标

PowerPAD, E2E are trademarks of Texas Instruments.
All other trademarks are the property of their respective owners.

11.5 静电放电警告



ESD 可能会损坏该集成电路。德州仪器 (TI) 建议通过适当的预防措施处理所有集成电路。如果不遵守正确的处理措施和安装程序，可能会损坏集成电路。

ESD 的损坏小至导致微小的性能降级，大至整个器件故障。精密的集成电路可能更容易受到损坏，这是因为非常细微的参数更改都可能会导致器件与其发布的规格不相符。

11.6 Glossary

[SLYZ022](#) — *TI Glossary*.

This glossary lists and explains terms, acronyms, and definitions.

12 机械、封装和可订购信息

以下页面包含机械、封装和可订购信息。这些信息是指定器件的最新可用数据。数据如有变更，恕不另行通知，也不会对此文档进行修订。如欲获取此数据表的浏览器版本，请参阅左侧的导航。

PACKAGING INFORMATION

| Orderable Device | Status (1) | Package Type | Package Drawing | Pins | Package Qty | Eco Plan (2) | Lead/Ball Finish (6) | MSL Peak Temp (3) | Op Temp (°C) | Device Marking (4/5) | Samples |
|------------------|---------------|--------------|-----------------|------|-------------|-------------------------|-------------------------|----------------------|--------------|-------------------------|-------------------------|
| XTR305IRGWR | ACTIVE | VQFN | RGW | 20 | 2000 | Green (RoHS & no Sb/Br) | CU NIPDAU | Level-2-260C-1 YEAR | -55 to 125 | XTR 305 | Samples |
| XTR305IRGWT | ACTIVE | VQFN | RGW | 20 | 250 | Green (RoHS & no Sb/Br) | CU NIPDAU | Level-2-260C-1 YEAR | -55 to 125 | XTR 305 | Samples |

(1) The marketing status values are defined as follows:

ACTIVE: Product device recommended for new designs.

LIFEBUY: TI has announced that the device will be discontinued, and a lifetime-buy period is in effect.

NRND: Not recommended for new designs. Device is in production to support existing customers, but TI does not recommend using this part in a new design.

PREVIEW: Device has been announced but is not in production. Samples may or may not be available.

OBSELETE: TI has discontinued the production of the device.

(2) **RoHS:** TI defines "RoHS" to mean semiconductor products that are compliant with the current EU RoHS requirements for all 10 RoHS substances, including the requirement that RoHS substance do not exceed 0.1% by weight in homogeneous materials. Where designed to be soldered at high temperatures, "RoHS" products are suitable for use in specified lead-free processes. TI may reference these types of products as "Pb-Free".

RoHS Exempt: TI defines "RoHS Exempt" to mean products that contain lead but are compliant with EU RoHS pursuant to a specific EU RoHS exemption.

Green: TI defines "Green" to mean the content of Chlorine (Cl) and Bromine (Br) based flame retardants meet JS709B low halogen requirements of <=1000ppm threshold. Antimony trioxide based flame retardants must also meet the <=1000ppm threshold requirement.

(3) MSL, Peak Temp. - The Moisture Sensitivity Level rating according to the JEDEC industry standard classifications, and peak solder temperature.

(4) There may be additional marking, which relates to the logo, the lot trace code information, or the environmental category on the device.

(5) Multiple Device Markings will be inside parentheses. Only one Device Marking contained in parentheses and separated by a "~" will appear on a device. If a line is indented then it is a continuation of the previous line and the two combined represent the entire Device Marking for that device.

(6) Lead/Ball Finish - Orderable Devices may have multiple material finish options. Finish options are separated by a vertical ruled line. Lead/Ball Finish values may wrap to two lines if the finish value exceeds the maximum column width.

Important Information and Disclaimer:The information provided on this page represents TI's knowledge and belief as of the date that it is provided. TI bases its knowledge and belief on information provided by third parties, and makes no representation or warranty as to the accuracy of such information. Efforts are underway to better integrate information from third parties. TI has taken and continues to take reasonable steps to provide representative and accurate information but may not have conducted destructive testing or chemical analysis on incoming materials and chemicals. TI and TI suppliers consider certain information to be proprietary, and thus CAS numbers and other limited information may not be available for release.

In no event shall TI's liability arising out of such information exceed the total purchase price of the TI part(s) at issue in this document sold by TI to Customer on an annual basis.

RGW (S-PVQFN-N20)

PLASTIC QUAD FLATPACK NO-LEAD

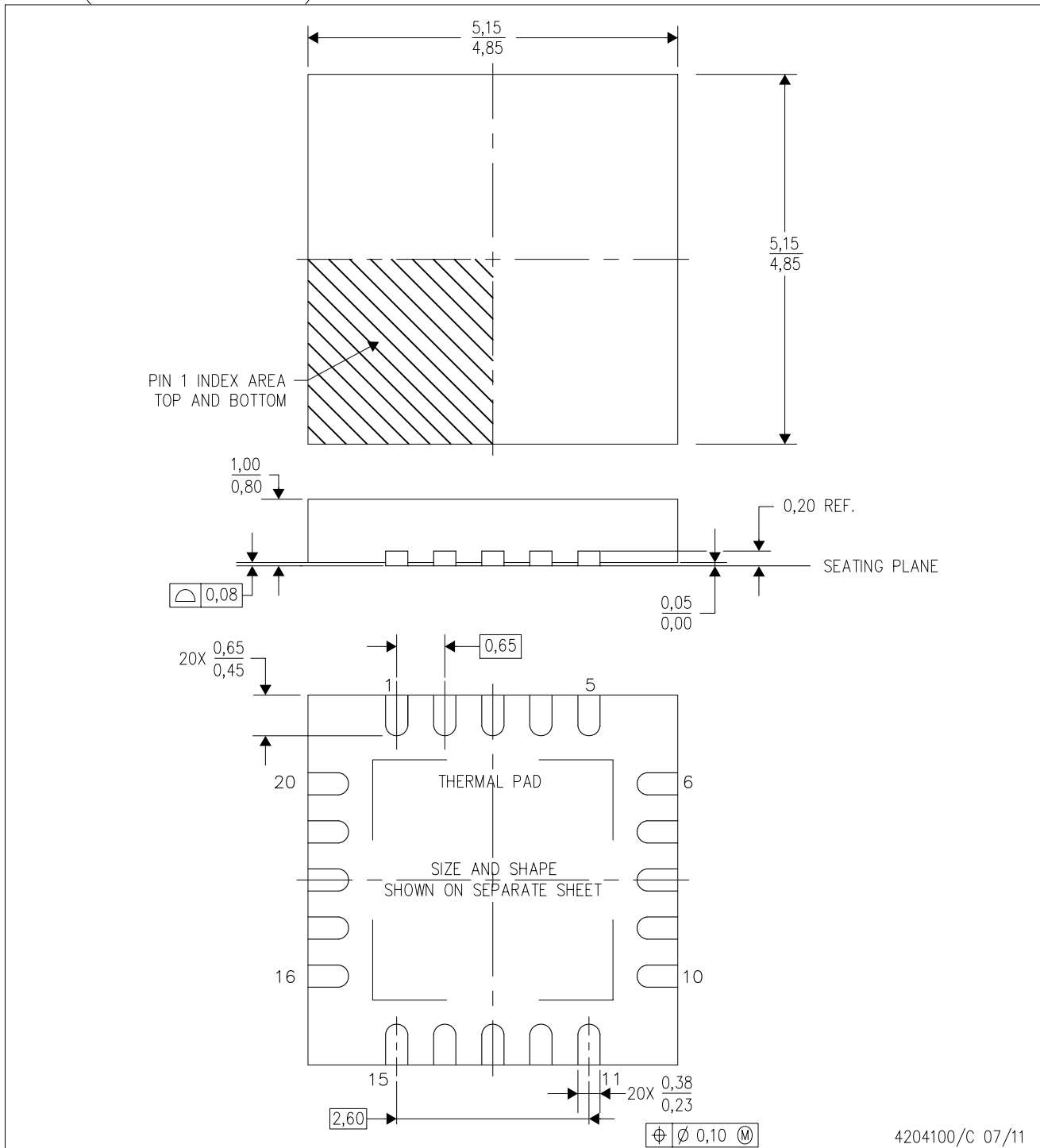

4204100/C 07/11

- NOTES:
- A. All linear dimensions are in millimeters. Dimensioning and tolerancing per ASME Y14.5-1994.
 - B. This drawing is subject to change without notice.
 - C. Quad Flat pack, No-leads (QFN) package configuration
 - D. The package thermal pad must be soldered to the board for thermal and mechanical performance.
 - E. See the additional figure in the Product Data Sheet for details regarding the exposed thermal pad features and dimensions.
 - F. Falls within JEDEC MO-220.

THERMAL INFORMATION

This package incorporates an exposed thermal pad that is designed to be attached directly to an external heatsink. The thermal pad must be soldered directly to the printed circuit board (PCB). After soldering, the PCB can be used as a heatsink. In addition, through the use of thermal vias, the thermal pad can be attached directly to the appropriate copper plane shown in the electrical schematic for the device, or alternatively, can be attached to a special heatsink structure designed into the PCB. This design optimizes the heat transfer from the integrated circuit (IC).

For information on the Quad Flatpack No-Lead (QFN) package and its advantages, refer to Application Report, QFN/SON PCB Attachment, Texas Instruments Literature No. SLUA271. This document is available at www.ti.com.

The exposed thermal pad dimensions for this package are shown in the following illustration.

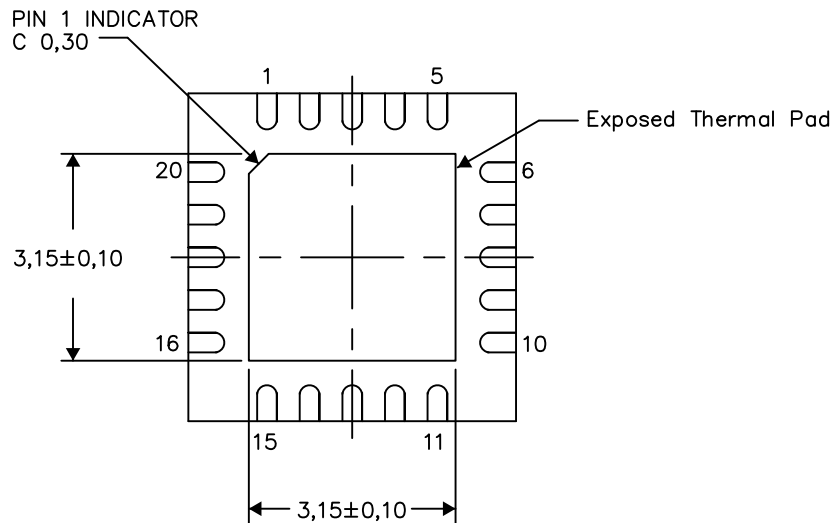

Bottom View

Exposed Thermal Pad Dimensions

4206352-2/M 06/15

NOTE: All linear dimensions are in millimeters

RGW (S-PVQFN-N20)

PLASTIC QUAD FLATPACK NO-LEAD

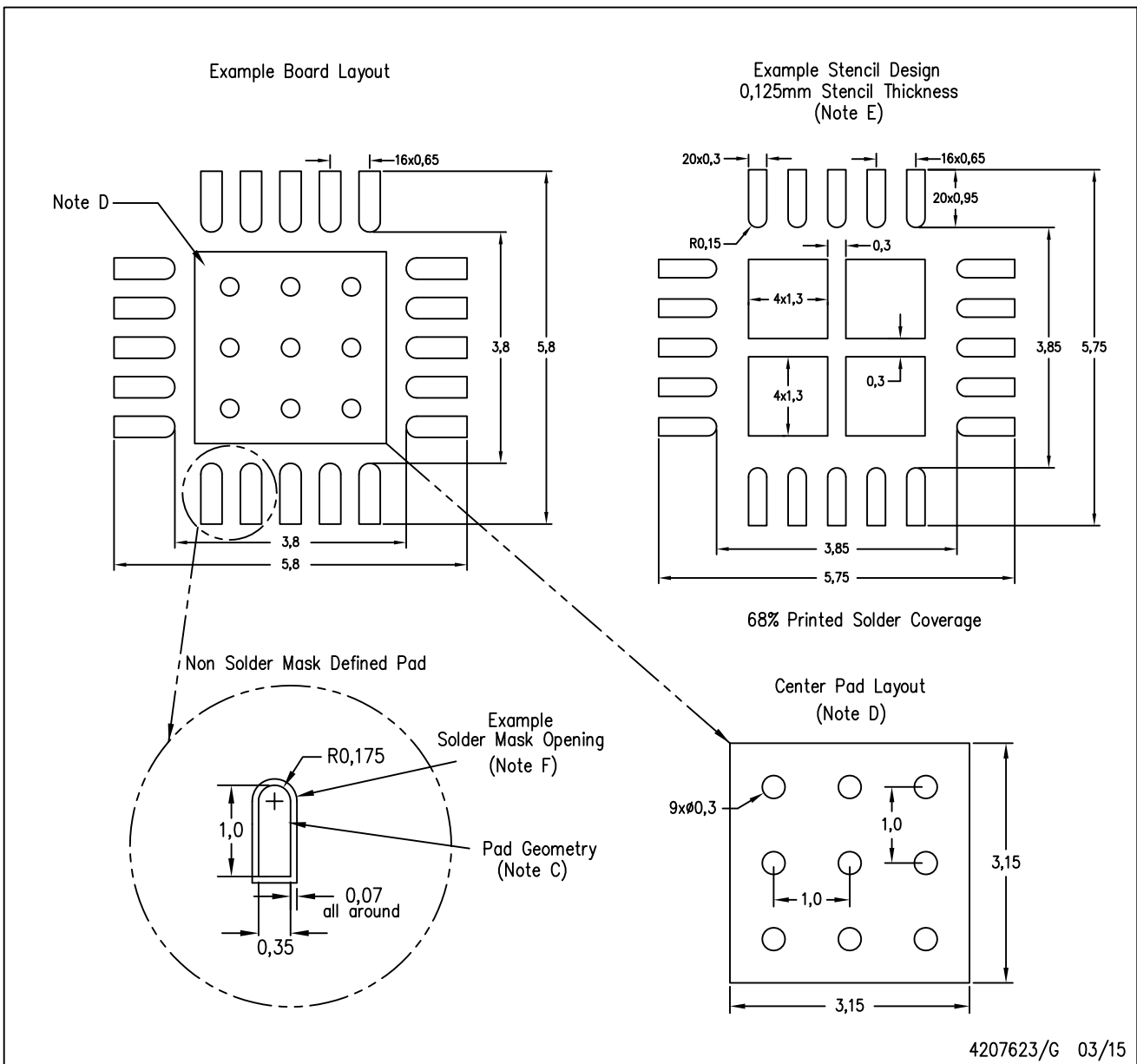

- NOTES:
- All linear dimensions are in millimeters.
 - This drawing is subject to change without notice.
 - Publication IPC-7351 is recommended for alternate designs.
 - This package is designed to be soldered to a thermal pad on the board. Refer to Application Note, QFN Packages, Texas Instruments Literature No. SLUA271, and also the Product Data Sheets for specific thermal information, via requirements, and recommended board layout. These documents are available at www.ti.com <<http://www.ti.com>>.
 - Laser cutting apertures with trapezoidal walls and also rounding corners will offer better paste release. Customers should contact their board assembly site for stencil design recommendations. Refer to IPC 7525 for stencil design considerations.
 - Customers should contact their board fabrication site for solder mask tolerances.

重要声明

德州仪器 (TI) 公司有权按照最新发布的 JESD46 对其半导体产品和服务进行纠正、增强、改进和其他修改，并不再按最新发布的 JESD48 提供任何产品和服务。买方在下订单前应获取最新的相关信息，并验证这些信息是否完整且是最新的。

TI 公布的半导体产品销售条款 (<http://www.ti.com/sc/docs/stdterms.htm>) 适用于 TI 已认证和批准上市的已封装集成电路产品的销售。另有其他条款可能适用于其他类型 TI 产品及服务的使用或销售。

复制 TI 数据表上 TI 信息的重要部分时，不得变更该等信息，且必须随附所有相关保证、条件、限制和通知，否则不得复制。TI 对该等复制文件不承担任何责任。第三方信息可能受到其它限制条件的制约。在转售 TI 产品或服务时，如果存在对产品或服务参数的虚假陈述，则会失去相关 TI 产品或服务的明示或暗示保证，且构成不公平的、欺诈性商业行为。TI 对此类虚假陈述不承担任何责任。

买方和在系统中整合 TI 产品的其他开发人员（总称“设计人员”）理解并同意，设计人员在设计应用时应自行实施独立的分析、评价和判断，且应全权负责并确保应用的安全性，及设计人员的应用（包括应用中使用的 TI 产品）应符合所有适用的法律法规及其他相关要求。设计人员就自己设计的应用声明，其具备制订和实施下列保障措施所需的一切必要专业知识，能够 (1) 预见故障的危险后果，(2) 监视故障及其后果，以及 (3) 降低可能导致危险的故障几率并采取适当措施。设计人员同意，在使用或分发包含 TI 产品的任何应用前，将彻底测试该等应用和和该等应用所用 TI 产品的功能而设计。

TI 提供技术、应用或其他设计建议、质量特点、可靠性数据或其他服务或信息，包括但不限于与评估模块有关的参考设计和材料（总称“TI 资源”），旨在帮助设计人员开发整合了 TI 产品的应用，如果设计人员（个人，或如果是代表公司，则为设计人员的公司）以任何方式下载、访问或使用任何特定的 TI 资源，即表示其同意仅为该等目标，按照本通知的条款使用任何特定 TI 资源。

TI 所提供的 TI 资源，并未扩大或以其他方式修改 TI 对 TI 产品的公开适用的质保及质保免责声明；也未导致 TI 承担任何额外的义务或责任。TI 有权对其 TI 资源进行纠正、增强、改进和其他修改。除特定 TI 资源的公开文档中明确列出的测试外，TI 未进行任何其他测试。

设计人员只有在开发包含该等 TI 资源所列 TI 产品的应用时，才被授权使用、复制和修改任何相关单项 TI 资源。但并未依据禁止反言原则或其他法律授予您任何 TI 知识产权的任何其他明示或默示的许可，也未授予您 TI 或第三方的任何技术或知识产权的许可，该等许可包括但不限于任何专利权、版权、屏蔽作品权或与应用 TI 产品或服务的任何整合、机器制作、流程相关的其他知识产权。涉及或参考了第三方产品或服务的信息不构成使用此类产品或服务的许可或与其相关的保证或认可。使用 TI 资源可能需要您向第三方获得对该等第三方专利或其他知识产权的许可。

TI 资源系“按原样”提供。TI 兹免除对资源及其使用作出所有其他明确或默示的保证或陈述，包括但不限于对准确性或完整性、产权保证、无屡发故障保证，以及适销性、适合特定用途和不侵犯任何第三方知识产权的任何默认保证。TI 不负责任何申索，包括但不限于因组合产品所致或与之有关的申索，也不为或对设计人员进行辩护或赔偿，即使该等产品组合已列于 TI 资源或其他地方。对因 TI 资源或其使用引起或与之有关的任何实际的、直接的、特殊的、附带的、间接的、惩罚性的、偶发的、从属或惩戒性损害赔偿，不管 TI 是否获悉可能会产生上述损害赔偿，TI 概不负责。

除 TI 已明确指出特定产品已达到特定行业标准（例如 ISO/TS 16949 和 ISO 26262）的要求外，TI 不对未达到任何该等行业标准要求而承担任何责任。

如果 TI 明确宣称产品有助于功能安全或符合行业功能安全标准，则该等产品旨在帮助客户设计和创作自己的符合相关功能安全标准和要求的的应用。在应用内使用产品的行为本身不会配有 任何安全特性。设计人员必须确保遵守适用于其应用的相关安全要求和标准而设计。设计人员不可将任何 TI 产品用于关乎性命的医疗设备，除非已由各方获得授权的管理人员签署专门的合同对此类应用专门作出规定。关乎性命的医疗设备是指出现故障会导致严重身体伤害或死亡的医疗设备（例如生命保障设备、心脏起搏器、心脏除颤器、人工心脏泵、神经刺激器以及植入设备）。此类设备包括但不限于，美国食品药品监督管理局认定为 III 类设备的设备，以及在美国以外的其他国家或地区认定为同等类别设备的所有医疗设备。

TI 可能明确指定某些产品具备某些特定资格（例如 Q100、军用级或增强型产品）。设计人员同意，其具备一切必要专业知识，可以为自己的应用选择适合的产品，并且正确选择产品的风险由设计人员承担。设计人员单方面负责遵守与该等选择有关的所有法律或监管要求。

设计人员同意向 TI 及其代表全额赔偿因其不遵守本通知条款和条件而引起的任何损害、费用、损失和/或责任。

邮寄地址：上海市浦东新区世纪大道 1568 号中建大厦 32 楼，邮政编码：200122
Copyright © 2018 德州仪器半导体技术（上海）有限公司